



## Service Manual

# Workman<sup>®</sup> HD Series

HD Model 07369 S/N 314000001 & Up,  
HDX/HDX-D Models with Kubota Gasoline & Diesel Engines

## Preface

The purpose of this publication is to provide the service technician with information for troubleshooting, testing, and repair of major systems and components on the Workman HD, HDX and HDX-D vehicles.

REFER TO THE OPERATOR'S MANUAL FOR OPERATING, MAINTENANCE AND ADJUSTMENT INSTRUCTIONS. For reference, insert a copy of the Operator's Manual and Parts Catalog for your machine into Chapter 2 of this service manual. Additional copies of the Operator's Manual and Parts Catalog are available on the internet at [www.Toro.com](http://www.Toro.com).

The Toro Company reserves the right to change product specifications or this publication without notice.



**This safety symbol means DANGER, WARNING, or CAUTION, PERSONAL SAFETY INSTRUCTION. When you see this symbol, carefully read the instructions that follow. Failure to obey the instructions may result in personal injury.**

**NOTE:** A **NOTE** will give general information about the correct operation, maintenance, service, testing, or repair of the machine.

**IMPORTANT:** The **IMPORTANT** notice will give important instructions which must be followed to prevent damage to systems or components on the machine.



This page is intentionally blank.

# Table Of Contents

## Chapter 1 - Safety

Safety Instructions	1 - 2
Safety and Instruction Decals	1 - 6

## Chapter 2 - Product Records and Maintenance

Product Records	2 - 1
Maintenance	2 - 1
Equivalents and Conversions	2 - 2
Torque Specifications	2 - 3

## Chapter 3 - Kubota EFI Gasoline Engine

Specifications	3 - 3
General Information	3 - 4
Service and Repairs	3 - 6
KUBOTA WORKSHOP MANUAL, GASOLINE ENGINE, WG972- G- E3F SERIES	
KUBOTA DIAGNOSTIC MANUAL, GASOLINE ENGINE, WG972- G- E3F SERIES	

## Chapter 4 - Kubota Diesel Engine

Specifications	4 - 2
General Information	4 - 3
Adjustments	4 - 4
Service and Repairs	4 - 6
KUBOTA WORKSHOP MANUAL, DIESEL ENGINE, SM- E3B SERIES	

## Chapter 5 - Kohler Air Cooled Gasoline Engine

Specifications	5 - 2
General Information	5 - 3
Service and Repairs	5 - 5
KOHLER COMMAND ENGINE SERVICE MANUAL	

## Chapter 6 - Drive Train

Specifications	6 - 2
General Information	6 - 3
Special Tools	6 - 4
Adjustments	6 - 5
Troubleshooting	6 - 6
Service and Repairs	6 - 10

## Chapter 7 - Chassis

Specifications	7 - 2
General Information	7 - 3
Special Tools	7 - 4
Troubleshooting	7 - 5
Service and Repairs	7 - 8

## Chapter 8 - Electrical System

Electrical Schematics	8 - 2
Special Tools	8 - 2
Troubleshooting	8 - 4
Electrical System Quick Checks	8 - 6
Component Testing	8 - 8
Service and Repairs	8 - 33

## Chapter 9 - Hydraulic System

Specifications	9 - 3
General Information	9 - 4
Special Tools	9 - 8
Hydraulic Schematics	9 - 10
Hydraulic Circuit Operation	9 - 12
Troubleshooting	9 - 15
Testing	9 - 18
Service and Repairs	9 - 37
SAUER/DANFOSS STEERING UNIT TYPE OSPM SERVICE MANUAL	

Safety

Product Records and Maintenance

Kubota EFI Gasoline Engine

Kubota Diesel Engine

Kohler Air Cooled Gasoline Engine

Drive Train

Chassis

Electrical System

Hydraulic System

This page is intentionally blank.



# Table Of Contents

---

## Chapter 10 - Front Wheel Drive (4WD)

Specifications .....	10 - 2
General Information .....	10 - 3
Service and Repairs .....	10 - 4
HILLIARD FRONT DRIVE DIFFERENTIAL PARTS and SERVICE MANUAL	

## Chapter 11 - Electrical Drawings

Electrical Drawing Designations .....	11 - 2
Electrical Schematics .....	11 - 3
Wire Harness Drawings .....	11 - 6

This page is intentionally blank.



## Table of Contents

SAFETY INSTRUCTIONS .....	2
Before Operating .....	2
While Operating .....	3
Maintenance and Service .....	4
Jacking Vehicle .....	5
Using Bed Safety Support .....	6
SAFETY AND INSTRUCTION DECALS .....	6

# Safety Instructions

The Workman HD series vehicles are designed and tested to offer safe service when operated and maintained properly. Although hazard control and accident prevention are partially dependent upon the design and configuration of the vehicle, these factors are also dependent upon the awareness, concern and proper training of the personnel involved in the operation, transport, maintenance and storage of the vehicle. Improper use or maintenance of the vehicle can result in injury or death. To reduce the potential for injury or death, comply with the following safety instructions.



---

## Before Operating

1. Review and understand the contents of the Operator's Manual and Operator's DVD before starting and operating the vehicle. Become familiar with the controls and know how to stop the vehicle and engine quickly. Additional copies of the Operator's Manual are available on the internet at [www.Toro.com](http://www.Toro.com).
2. Keep all shields, safety devices and decals in place. If a shield, safety device or decal is defective, illegible or damaged, repair or replace it before operating the vehicle. Also tighten any loose nuts, bolts or screws to ensure vehicle is in safe operating condition.
3. Assure interlock switches are adjusted correctly so engine cannot be started unless clutch pedal is depressed and hydraulic lever is in the neutral position. On vehicles equipped with the optional PTO kit, engine should start only when PTO is disengaged.

4. Since fuel used in Workman vehicles is highly flammable, handle it carefully:

- A. Store fuel in containers specifically designed for this purpose.
- B. Do not remove vehicle fuel tank cap while engine is hot or running.
- C. Do not smoke while handling fuel.
- D. Fill fuel tank outdoors and only to within an inch of the top of the tank, not the filler neck. Do not overfill the fuel tank.
- E. Wipe up any spilled fuel.

---

## While Operating

1. Sit on the operator seat when starting and operating the vehicle.
2. When starting the engine:
  - A. Sit on operator's seat and engage the parking brake.
  - B. Disengage PTO (if so equipped) and return hand throttle lever to OFF position (if so equipped).
  - C. Make sure that hydraulic lift lever is in the neutral position.
  - D. Move shift lever to NEUTRAL and depress clutch pedal. Keep foot off accelerator pedal.
  - E. Turn ignition key to START.
3. Do not run engine in a confined area without adequate ventilation. Exhaust fumes are hazardous and could possibly be deadly.
4. Do not touch engine, exhaust system components, transaxle or radiator (if equipped), while engine is running or soon after it is stopped. These areas could be hot enough to cause burns.
5. Before getting off the seat:
  - A. Stop movement of the vehicle.
  - B. Lower bed.
  - C. Shut engine off and wait for all movement to stop.
  - D. Engage parking brake and remove key from ignition switch.
6. Do not park on slopes unless wheels are chocked or blocked.

---

## Maintenance and Service

1. Before servicing or making adjustments, turn all accessories off, put traction pedal in neutral, stop engine, engage parking brake and remove key from the ignition switch.
2. Make sure vehicle is in safe operating condition by keeping all nuts, bolts and screws tight.
3. Never store the vehicle or fuel container inside where there is an open flame, such as near a water heater or furnace.
4. Never work under a raised bed without placing the bed safety support on the fully extended lift cylinder rod.
5. Make sure all hydraulic line connectors are tight and that all hydraulic hoses and lines are in good condition, before applying pressure to the system.
6. Keep body and hands away from pin hole leaks in hydraulic lines that eject high pressure hydraulic fluid. Use cardboard or paper to find hydraulic leaks. Hydraulic fluid escaping under pressure can penetrate skin and cause injury. Fluid accidentally injected into the skin must be surgically removed within a few hours by a doctor familiar with this form of injury or gangrene may result.
7. Before disconnecting or performing any work on the hydraulic system, all pressure in hydraulic system must be relieved. To relieve system pressure, push hydraulic lever forward and backward and rotate steering wheel in both directions after the ignition switch has been turned off.
8. If major repairs are ever needed or assistance is desired, contact an Authorized Toro Distributor.
9. To reduce potential fire hazard, keep engine area free of excessive grease, grass, leaves and dirt.
10. If engine must be running to perform maintenance or an adjustment, keep clothing, hands, feet and other parts of the body away from moving parts. Keep bystanders away.
11. Do not overspeed the engine by changing governor setting. To ensure safety and accuracy, check maximum engine speed.
12. Shut engine off before checking or adding oil to the engine crankcase.
13. Disconnect battery before servicing the vehicle. Disconnect negative (-) battery cable first and positive (+) cable last. If battery voltage is required for troubleshooting or test procedures, temporarily connect the battery. Connect positive (+) cable first and negative (-) cable last.
14. Battery acid is poisonous and can cause burns. Avoid contact with skin, eyes and clothing. Protect your face, eyes and clothing when working with a battery.
15. Battery gases can explode. Keep cigarettes, sparks and flames away from the battery.
16. To ensure optimum performance and continued safety of the vehicle, use genuine Toro replacement parts and accessories. Replacement parts and accessories made by other manufacturers may result in non-conformance with safety standards and the warranty may be voided.
17. When raising the vehicle to change tires or to perform other service, use correct blocks, hoists and jacks. Make sure vehicle is parked on a solid level surface such as a concrete floor. Prior to raising the vehicle, remove any attachments that may interfere with the safe and proper raising of the vehicle. Always chock or block wheels. Use appropriate jack stands to support the raised vehicle. If the vehicle is not properly supported by jack stands, the vehicle may move or fall, which may result in personal injury (see Jacking Vehicle in this section).

## Jacking Vehicle



### WARNING

When changing attachments, tires or performing other service, use correct jacks, hoists and jack stands. Always chock or block the wheels and use jack stands to support the vehicle. If the vehicle is not properly supported by jack stands, the vehicle may move or fall resulting in personal injury.

1. Do not start engine while vehicle is on jack, because engine vibration or wheel movement could cause vehicle to slip off jack.
2. Do not work under vehicle without jack stands supporting it. The vehicle could slip off jack, injuring any one beneath it.
3. The jacking point at the front of the vehicle is under the front center frame support (Fig. 1). When jacking up front of vehicle, always place a wood block (or similar material) between jack and vehicle frame support.
4. The jacking point at the rear of the vehicle is under the axle tube (Fig. 2).

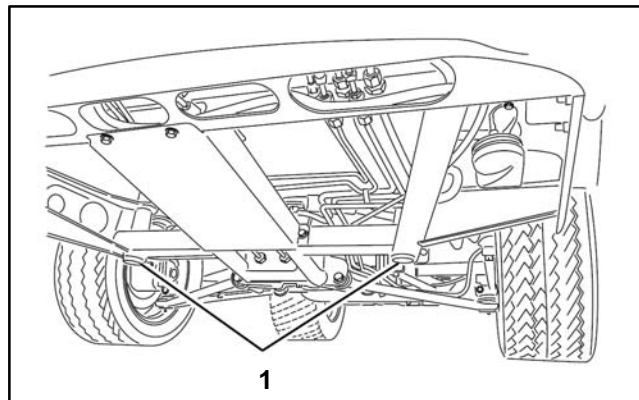

Figure 1

1. Front jacking point

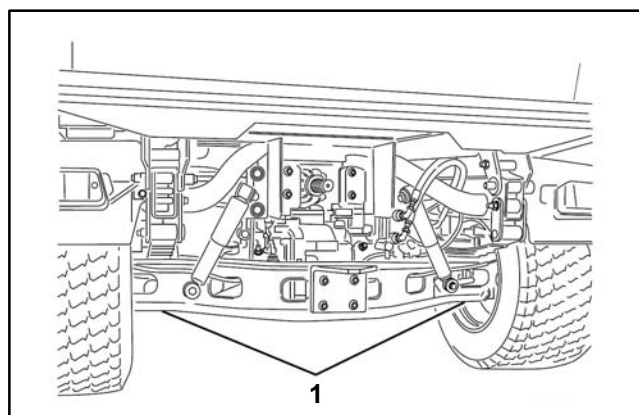

Figure 2

1. Rear jacking point

## Using Bed Safety Support

Many of the procedures shown in this manual require raising and lowering the bed. The following precautions must be taken or serious injury or death could result.



### WARNING

Before servicing or making adjustments to the vehicle, stop engine, engage parking brake and remove key from ignition switch. Any load material must be removed from bed or other attachment before working under raised bed. Never work under a raised bed without positioning bed safety support on a fully extended cylinder rod.

After work is completed, remove bed safety support, insert safety support into storage brackets on back of ROPS panel and lower bed.

1. Raise bed until lift cylinders are fully extended.
2. Remove bed safety support from storage brackets on back of ROPS panel.
3. Push bed safety support onto cylinder rod, making sure support end tabs rest on end of cylinder barrel and on cylinder rod end (Fig. 3).
4. To store bed safety support, remove support from lift cylinder and insert into storage brackets on back of ROPS panel.
5. Always install or remove bed safety support from outside of bed.
6. Do not try to lower bed with bed safety support on lift cylinder: cylinder and bed damage may occur.

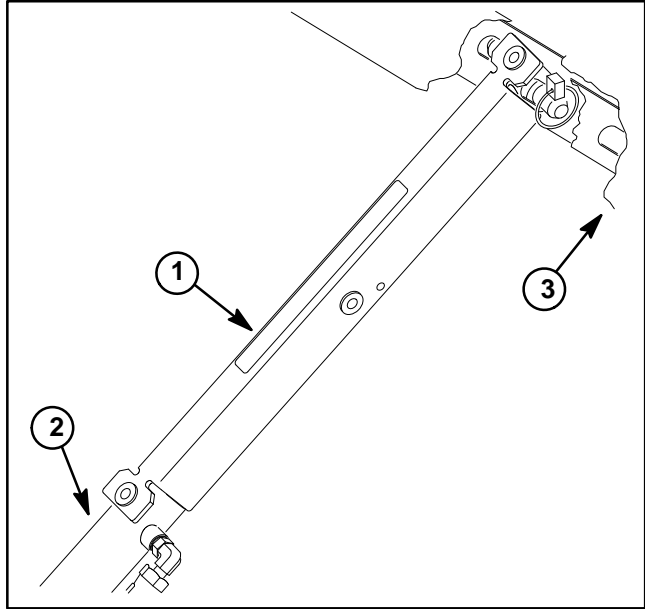

Figure 3

1. Bed safety support
2. Cylinder barrel
3. Bed

## Safety and Instruction Decals

Numerous safety and instruction decals are affixed to the Workman HD vehicle. If any decal becomes illegible or damaged, install a new decal. Decal descriptions and part numbers are listed in the vehicle Operator's Manual and Parts Catalog.





# Product Records and Maintenance

## Table of Contents

PRODUCT RECORDS .....	1
MAINTENANCE .....	1
EQUIVALENTS AND CONVERSIONS .....	2
Decimal and Millimeter Equivalents .....	2
U.S. to Metric Conversions .....	2
TORQUE SPECIFICATIONS .....	3
Fastener Identification .....	3
Using a Torque Wrench with an Offset Wrench ..	3
Standard Torque for Dry, Zinc Plated and Steel Fasteners (Inch Series Fasteners) .....	4
Standard Torque for Dry, Zinc Plated and Steel Fasteners (Metric Fasteners) .....	5
Other Torque Specifications .....	6
Conversion Factors .....	6

## Product Records

Insert Operator's Manual and Parts Catalog for your Workman HD series vehicle at the end of this chapter. Refer to Operator's Manual for recommended maintenance intervals. Additionally, insert Installation Instructions, Operator's Manuals, Parts Catalogs and Service Manuals for any accessories that have been installed on your Workman at the end of this section.

## Maintenance

Maintenance procedures and recommended service intervals for the Workman HD series vehicles are covered in the Operator's Manual. Refer to that publication when performing regular equipment maintenance. Several maintenance procedures have break-in intervals identified in the Operator's Manual. Refer to the Engine Operator's Manual for additional engine specific maintenance procedures.



# Torque Specifications

Recommended fastener torque values are listed in the following tables. For critical applications, as determined by Toro, either the recommended torque or a torque that is unique to the application is clearly identified and specified in this Service Manual.

These Torque Specifications for the installation and tightening of fasteners shall apply to all fasteners which do not have a specific requirement identified in this Service Manual. The following factors shall be considered when applying torque: cleanliness of the fastener, use of a thread sealant (e.g. Loctite), degree of lubrication on the fastener, presence of a prevailing torque feature (e.g. Nylock nut), hardness of the surface underneath the fastener's head or similar condition which affects the installation.

As noted in the following tables, torque values should be **reduced by 25% for lubricated fasteners** to achieve the similar stress as a dry fastener. Torque values may also have to be reduced when the fastener is threaded into aluminum or brass. The specific torque value should be determined based on the aluminum or brass material strength, fastener size, length of thread engagement, etc.

The standard method of verifying torque shall be performed by marking a line on the fastener (head or nut) and mating part, then back off fastener 1/4 of a turn. Measure the torque required to tighten the fastener until the lines match up.

## Fastener Identification

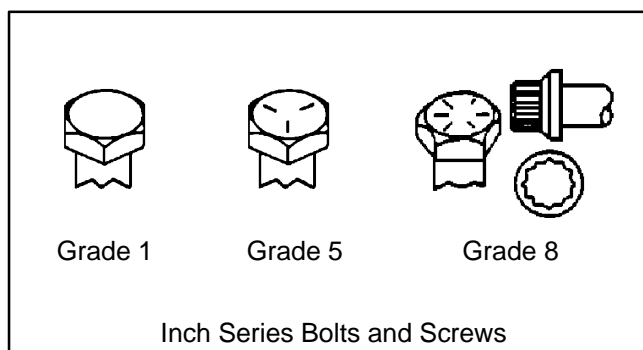

Figure 1

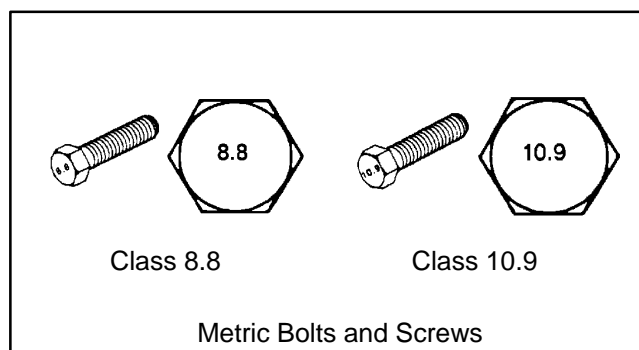

Figure 2

## Using a Torque Wrench with an Offset Wrench

Use of an offset wrench (e.g. crowfoot wrench) will affect torque wrench calibration due to the effective change of torque wrench length. When using a torque wrench with an offset wrench, multiply the listed torque recommendation by the calculated torque conversion factor (Fig. 3) to determine proper tightening torque. Tightening torque when using a torque wrench with an offset wrench will be lower than the listed torque recommendation.

**Example:** The measured effective length of the torque wrench (distance from the center of the handle to the center of the square drive) is 18".

The measured effective length of the torque wrench with the offset wrench installed (distance from the center of the handle to the center of the offset wrench) is 19".

The calculated torque conversion factor for this torque wrench with this offset wrench would be  $18 / 19 = 0.947$ .

If the listed torque recommendation for a fastener is from 76 to 94 ft-lb, the proper torque when using this torque wrench with an offset wrench would be from 72 to 89 ft-lb.

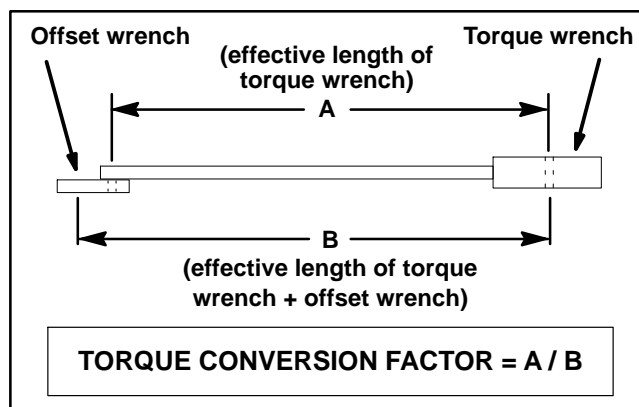

Figure 3

## Standard Torque for Dry, Zinc Plated and Steel Fasteners (Inch Series Fasteners)

Thread Size	Grade 1, 5 & 8 with Thin Height Nuts	SAE Grade 1 Bolts, Screws, Studs & Sems with Regular Height Nuts (SAE J995 Grade 2 or Stronger Nuts)		SAE Grade 5 Bolts, Screws, Studs & Sems with Regular Height Nuts (SAE J995 Grade 2 or Stronger Nuts)		SAE Grade 8 Bolts, Screws, Studs & Sems with Regular Height Nuts (SAE J995 Grade 5 or Stronger Nuts)	
	in-lb	in-lb	N-cm	in-lb	N-cm	in-lb	N-cm
# 6 – 32 UNC	10 ± 2	13 ± 2	147 ± 23	15 ± 2	169 ± 23	23 ± 3	262 ± 34
# 6 – 40 UNF				17 ± 2	192 ± 23	25 ± 3	282 ± 34
# 8 – 32 UNC	13 ± 2	25 ± 5	282 ± 30	29 ± 3	328 ± 34	41 ± 5	463 ± 56
# 8 – 36 UNF				31 ± 4	350 ± 45	43 ± 5	486 ± 56
# 10 – 24 UNC	18 ± 2	30 ± 5	339 ± 56	42 ± 5	475 ± 56	60 ± 6	678 ± 68
# 10 – 32 UNF				48 ± 5	542 ± 56	68 ± 7	768 ± 79
1/4 – 20 UNC	48 ± 7	53 ± 7	599 ± 79	100 ± 10	1130 ± 113	140 ± 15	1582 ± 169
1/4 – 28 UNF	53 ± 7	65 ± 10	734 ± 113	115 ± 12	1299 ± 136	160 ± 17	1808 ± 192
5/16 – 18 UNC	115 ± 15	105 ± 15	1186 ± 169	200 ± 25	2260 ± 282	300 ± 30	3390 ± 339
5/16 – 24 UNF	138 ± 17	128 ± 17	1446 ± 192	225 ± 25	2542 ± 282	325 ± 33	3672 ± 373
	ft-lb	ft-lb	N-m	ft-lb	N-m	ft-lb	N-m
3/8 – 16 UNC	16 ± 2	16 ± 2	22 ± 3	30 ± 3	41 ± 4	43 ± 5	58 ± 7
3/8 – 24 UNF	17 ± 2	18 ± 2	24 ± 3	35 ± 4	47 ± 5	50 ± 6	68 ± 8
7/16 – 14 UNC	27 ± 3	27 ± 3	37 ± 4	50 ± 5	68 ± 7	70 ± 7	95 ± 9
7/16 – 20 UNF	29 ± 3	29 ± 3	39 ± 4	55 ± 6	75 ± 8	77 ± 8	104 ± 11
1/2 – 13 UNC	30 ± 3	48 ± 7	65 ± 9	75 ± 8	102 ± 11	105 ± 11	142 ± 15
1/2 – 20 UNF	32 ± 4	53 ± 7	72 ± 9	85 ± 9	115 ± 12	120 ± 12	163 ± 16
5/8 – 11 UNC	65 ± 10	88 ± 12	119 ± 16	150 ± 15	203 ± 20	210 ± 21	285 ± 28
5/8 – 18 UNF	75 ± 10	95 ± 15	129 ± 20	170 ± 18	230 ± 24	240 ± 24	325 ± 33
3/4 – 10 UNC	93 ± 12	140 ± 20	190 ± 27	265 ± 27	359 ± 37	375 ± 38	508 ± 52
3/4 – 16 UNF	115 ± 15	165 ± 25	224 ± 34	300 ± 30	407 ± 41	420 ± 43	569 ± 58
7/8 – 9 UNC	140 ± 20	225 ± 25	305 ± 34	430 ± 45	583 ± 61	600 ± 60	813 ± 81
7/8 – 14 UNF	155 ± 25	260 ± 30	353 ± 41	475 ± 48	644 ± 65	667 ± 66	904 ± 89

**NOTE:** Reduce torque values listed in the table above by 25% for lubricated fasteners. Lubricated fasteners are defined as threads coated with a lubricant such as engine oil or thread sealant such as Loctite.

**NOTE:** Torque values may have to be reduced when installing fasteners into threaded aluminum or brass. The specific torque value should be determined based on the fastener size, the aluminum or base material strength, length of thread engagement, etc.

**NOTE:** The nominal torque values listed above for Grade 5 and 8 fasteners are based on 75% of the minimum proof load specified in SAE J429. The tolerance is approximately ± 10% of the nominal torque value. Thin height nuts include jam nuts.

## Standard Torque for Dry, Zinc Plated and Steel Fasteners (Metric Fasteners)

Thread Size	Class 8.8 Bolts, Screws and Studs with Regular Height Nuts (Class 8 or Stronger Nuts)		Class 10.9 Bolts, Screws and Studs with Regular Height Nuts (Class 10 or Stronger Nuts)	
M5 X 0.8	57 ± 6 in-lb	644 ± 68 N-cm	78 ± 8 in-lb	881 ± 90 N-cm
M6 X 1.0	96 ± 10 in-lb	1085 ± 113 N-cm	133 ± 14 in-lb	1503 ± 158 N-cm
M8 X 1.25	19 ± 2 ft-lb	26 ± 3 N-m	28 ± 3 ft-lb	38 ± 4 N-m
M10 X 1.5	38 ± 4 ft-lb	52 ± 5 N-m	54 ± 6 ft-lb	73 ± 8 N-m
M12 X 1.75	66 ± 7 ft-lb	90 ± 10 N-m	93 ± 10 ft-lb	126 ± 14 N-m
M16 X 2.0	166 ± 17 ft-lb	225 ± 23 N-m	229 ± 23 ft-lb	310 ± 31 N-m
M20 X 2.5	325 ± 33 ft-lb	440 ± 45 N-m	450 ± 46 ft-lb	610 ± 62 N-m

**NOTE:** Reduce torque values listed in the table above by 25% for lubricated fasteners. Lubricated fasteners are defined as threads coated with a lubricant such as engine oil or thread sealant such as Loctite.

**NOTE:** The nominal torque values listed above are based on 75% of the minimum proof load specified in SAE J1199. The tolerance is approximately ± 10% of the nominal torque value.

**NOTE:** Torque values may have to be reduced when installing fasteners into threaded aluminum or brass. The specific torque value should be determined based on the fastener size, the aluminum or base material strength, length of thread engagement, etc.

## Other Torque Specifications

### SAE Grade 8 Steel Set Screws

Thread Size	Recommended Torque	
	Square Head	Hex Socket
1/4 – 20 UNC	140 ± 20 in-lb	73 ± 12 in-lb
5/16 – 18 UNC	215 ± 35 in-lb	145 ± 20 in-lb
3/8 – 16 UNC	35 ± 10 ft-lb	18 ± 3 ft-lb
1/2 – 13 UNC	75 ± 15 ft-lb	50 ± 10 ft-lb

### Wheel Bolts and Lug Nuts

Thread Size	Recommended Torque**	
7/16 – 20 UNF Grade 5	65 ± 10 ft-lb	88 ± 14 N-m
1/2 – 20 UNF Grade 5	80 ± 10 ft-lb	108 ± 14 N-m
M12 X 1.25 Class 8.8	80 ± 10 ft-lb	108 ± 14 N-m
M12 X 1.5 Class 8.8	80 ± 10 ft-lb	108 ± 14 N-m

\*\* For steel wheels and non-lubricated fasteners.

### Thread Cutting Screws (Zinc Plated Steel)

Type 1, Type 23 or Type F	
Thread Size	Baseline Torque*
No. 6 – 32 UNC	20 ± 5 in-lb
No. 8 – 32 UNC	30 ± 5 in-lb
No. 10 – 24 UNC	38 ± 7 in-lb
1/4 – 20 UNC	85 ± 15 in-lb
5/16 – 18 UNC	110 ± 20 in-lb
3/8 – 16 UNC	200 ± 100 in-lb

### Thread Cutting Screws (Zinc Plated Steel)

Thread Size	Threads per Inch		Baseline Torque*
	Type A	Type B	
No. 6	18	20	20 ± 5 in-lb
No. 8	15	18	30 ± 5 in-lb
No. 10	12	16	38 ± 7 in-lb
No. 12	11	14	85 ± 15 in-lb

\* Hole size, material strength, material thickness and finish must be considered when determining specific torque values. All torque values are based on non-lubricated fasteners.

## Conversion Factors

$$\begin{aligned} \text{in-lb} \times 11.2985 &= \text{N-cm} \\ \text{ft-lb} \times 1.3558 &= \text{N-m} \end{aligned}$$

$$\begin{aligned} \text{N-cm} \times 0.08851 &= \text{in-lb} \\ \text{N-m} \times 0.7376 &= \text{ft-lb} \end{aligned}$$



# Kubota EFI Gasoline Engine

## Table of Contents

SPECIFICATIONS .....	3	Fuel System .....	10
GENERAL INFORMATION .....	4	Fuel Tank .....	11
Introduction .....	4	Fuel pump .....	12
Operator's Manual .....	4	Carbon canister .....	13
Kubota Workshop and Diagnostics Manuals .....	3	Radiator .....	14
Kubota Gasoline Engine .....	3	Engine .....	16
Kubota Gasoline Engine		KUBOTA WORKSHOP MANUAL, GASOLINE EN-	
Electronic Control Unit (ECU) .....	5	GINE, WG972-G-E3F	
SERVICE AND REPAIRS .....	6	KUBOTA DIAGNOSTICS MANUAL, GASOLINE EN-	
Air Cleaner System .....	6	GINE, WG972-G-E3F	
Exhaust System .....	8		

Kubota EFI  
Gasoline Engine

This page is intentionally left blank.



# Specifications

Item	Description
Make / Designation	Kubota, Vertical, 4-Cycle, 3 Cylinder, Liquid Cooled, Gasoline Engine
Bore	2.93 in (74.5 mm)
Stroke	2.90 in. (73.6 mm)
Total Displacement	58.68 cu. In. (962 cc)
Compression Ratio	9.2:1
Ignition Timing	31_ BTDC @ 3600 rpm
Ignition System	Full Transistor Battery Ignition Type
Firing Order	1-2-3
Spark Plug Type/Gap	NGK BKR6E 0.028 to 0.031 in. (0.7 to 0.8 mm)
Intake & Exhaust Valve Clearance (check when engine is cold)	0.0065 ± 0.0001 in. (0.165 ± 0.02 mm)
Fuel	Unleaded Gasoline (up to 10% ethanol)
Fuel Capacity	6.5 Gal (24.6 Ltr)
Governor	Electronic
Low Idle (no load)	1100 ± 50 RPM
High Idle (no load)	3600 ± 50 RPM
Direction of Rotation	Counterclockwise (Viewed from Flywheel)
Engine Oil	API classification SL or higher (see Vehicle Operator's Manual for viscosity recommendations)
Oil Pump	Trochoid Type
Crankcase Oil Capacity	3.5 qt. (3.3 ltr.) with Filter
Starter	12 VDC, 1.2 KW
Alternator/Regulator	12 VDC, 480W
Dry Weight U.S.	163 lbs. (74 Kg)
Coolant Capacity U.S.	3.7 qt. (3.5 ltr.) with 1.0 qt. (0.9 ltr.) Reservoir

# Introduction

This Chapter gives information about specifications, maintenance, troubleshooting, testing, and repair of the Kubota EFI gasoline engine used in the Workman HDX.

Most repairs and adjustments require tools which are commonly available in many service shops. The use of some specialized test equipment is explained in the engine service manual included at the end of this chapter. However, the cost of the test equipment and the specialized nature of some repairs may dictate that the work be done at an engine repair facility.

Service and repair parts for Kubota gasoline engines are supplied through your local Toro Distributor. If a parts list is not available, be sure to provide your distributor with the Toro model and serial number.

---

## Traction Unit Operator's Manuals

The Vehicle Operator's Manual provides information regarding the operation, general maintenance and maintenance intervals for your Workman HDX. Refer to this publication for additional information when servicing the machine.

---

## Kubota Workshop and Diagnostics Manuals

The engine that powers your Workman HDX is a Kubota model WG972-G-E3F. Both the Kubota Workshop Manual and Kubota Diagnostics Manual are available for this engine. Make sure that the correct engine manuals are used when servicing the engine.

---

## Kubota Gasoline Engine

The engine used in your Workman HDX is a Kubota WG972 Series gasoline engine. Engine features include an electronic control unit (ECU) that controls a common rail fuel injection system with direct injection, electronic throttle valve (ETV), an electronic governor and a catalytic muffler exhaust system with an oxygen sensor. The ECU receives information from numerous engine sensors. The information provided allows the engine ECU to monitor and control engine operation for optimum engine performance.

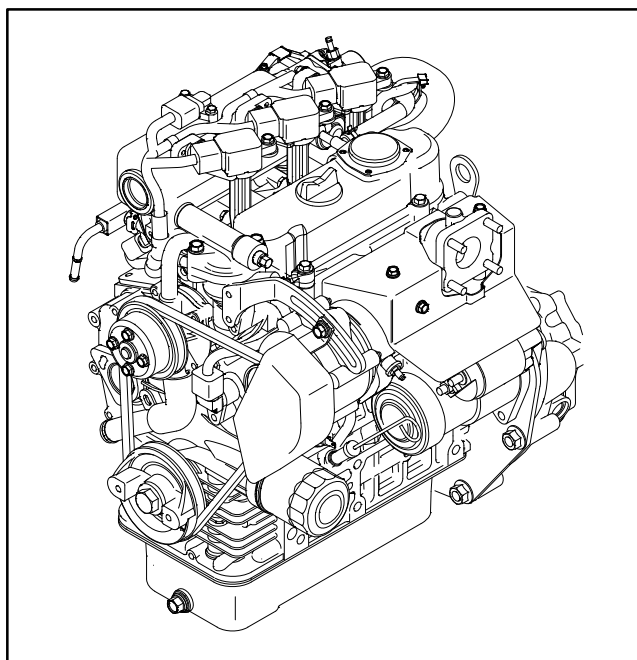

Figure 1

## Kubota Gasoline Engine Electronic Control Unit (ECU)

The Kubota gasoline engine that powers your Workman HDX uses an electronic control unit (ECU) for engine management. All wire harness electrical connectors should be plugged into the ECU before the machine ignition switch is moved from the OFF position to either the ON or START position.

The engine electrical components (e.g. ECU, O2 sensor, throttle control, power relay, ETV relay) are identified and matched in the engine ECU program. If engine electrical components are replaced on the engine, the Kubota electronic tool must be used to update the ECU program which will ensure correct engine operation.

If the engine ECU identifies that an engine problem exists, the check engine light on the Operator's Control Panel will illuminate. The engine speed may be reduced or the engine might stop. The Kubota Gasoline Service Tool (KGST) and software, and the Kubota Diagnostic Manual should be used to provide assistance in identifying the cause of the problem and any repairs that are necessary. Connect the Kubota Gasoline Service Tool (KGST) to the diagnostic connector above the engine ECU (Fig. 3). Contact your Toro distributor for assistance in Kubota engine troubleshooting.

**IMPORTANT: Two (2) communication connectors are located near the engine ECU. The connector along side of the ECU (near the middle of the engine) is not used for service diagnostics.**

**Do not plug or unplug the engine ECU for a period of thirty (30) seconds after the machine key switch is turned OFF. The ECU may remain energized even though the ignition switch is OFF.**

If the engine ECU is to be disconnected for any reason, make sure that the ignition switch is in the OFF position with the key removed before disconnecting the engine ECU. Also, to prevent possible ECU damage when welding on the machine, disconnect and remove the engine ECU from the machine before welding.

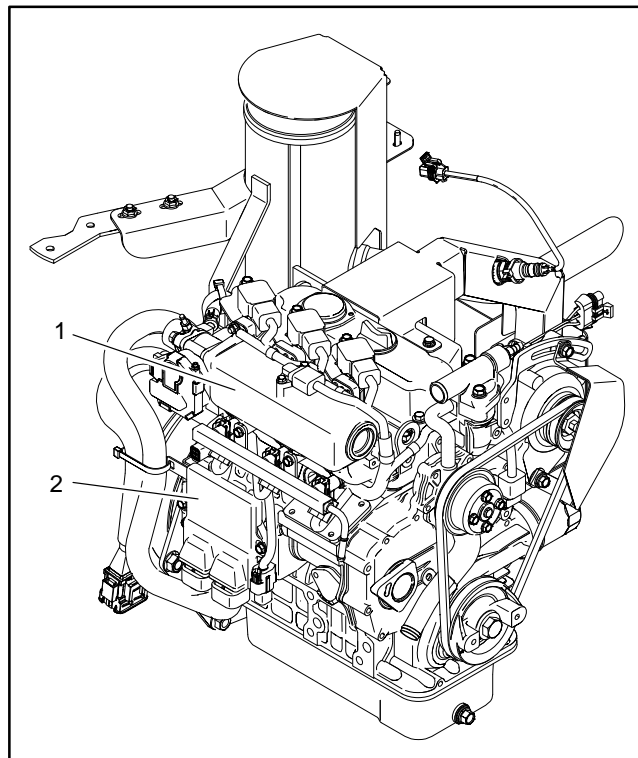

Figure 2

1. Engine (Model 30809)
2. Engine ECU

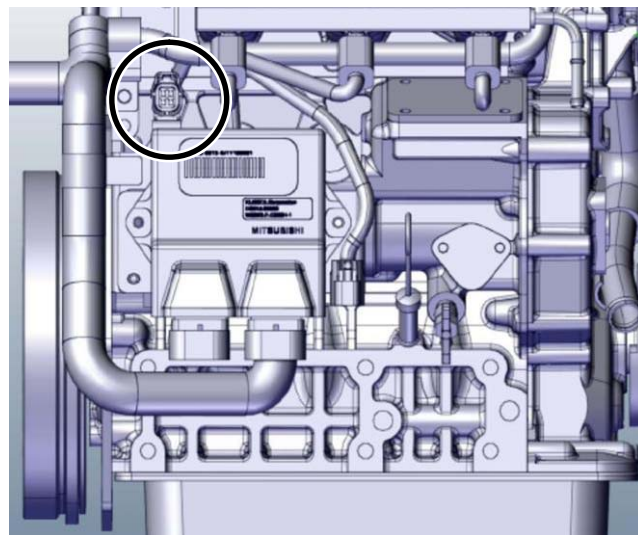

Figure 3  
Diagnostic connector

# Service and Repairs

## Air Cleaner System

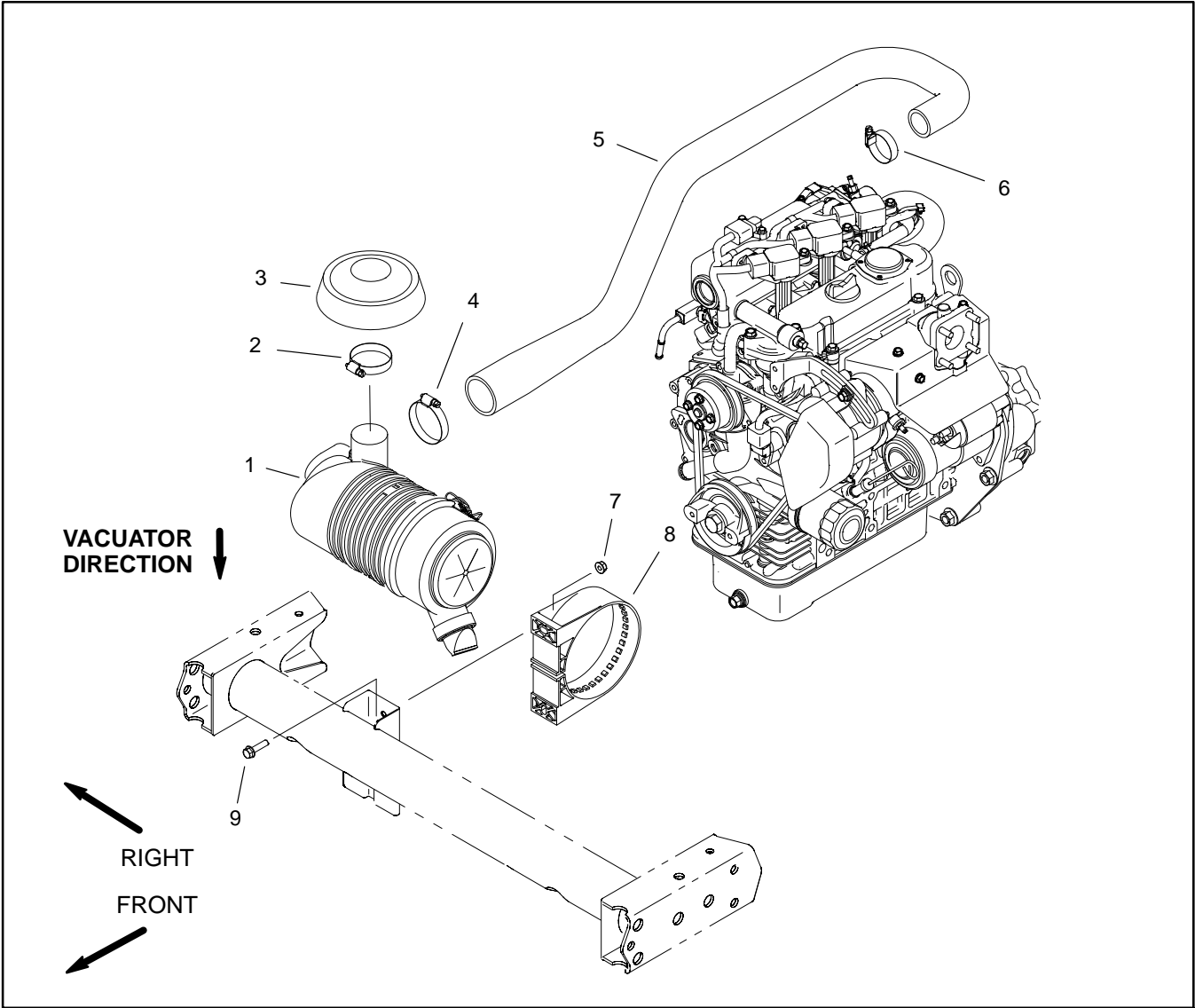

Figure 4

- 1. Air cleaner assembly
- 2. Hose clamp
- 3. Air inlet hood
- 4. Hose clamp
- 5. Air intake hose
- 6. Hose clamp
- 7. Flange nut (2)
- 8. Mounting bracket
- 9. Flange head screw (2)

## Check Air Filter, Dust Cup, & Burp Valve

The air cleaner body, air filter, dust cup, and burp valve should be checked daily, prior to operation.

**IMPORTANT: Any leaks in the air cleaner system will cause serious engine damage. Make sure that all air cleaner components are in good condition and are properly secured during operation.**

1. Park machine on a level surface, lower cutting units, stop engine, engage parking brake, and remove key from the ignition switch. Unlatch and raise hood.
2. Check air cleaner body for damage that could cause possible air leaks. Make sure cover seals completely to the air cleaner body (Fig. 5).
3. Check burp valve and dust cup for damage.
4. Make sure air hoses connecting the air cleaner to the engine and radiator are secured tightly and free of possible air leaks.

## Air Cleaner Removal

1. Park vehicle on a level surface and engage parking brake. Stop the engine and remove key from ignition switch. Allow engine to cool.
2. Raise or remove the bed or other attachment(s) if necessary. If bed is raised, place safety support on lift cylinder.
3. Remove air cleaner components as needed.

## Air Cleaner Installation

1. Assemble air cleaner system (Fig. 4). Air cleaner inlet hood should be positioned straight upward. The vacuator valve on the air cleaner assembly should be positioned downward.
2. Lower or install bed or attachment(s).

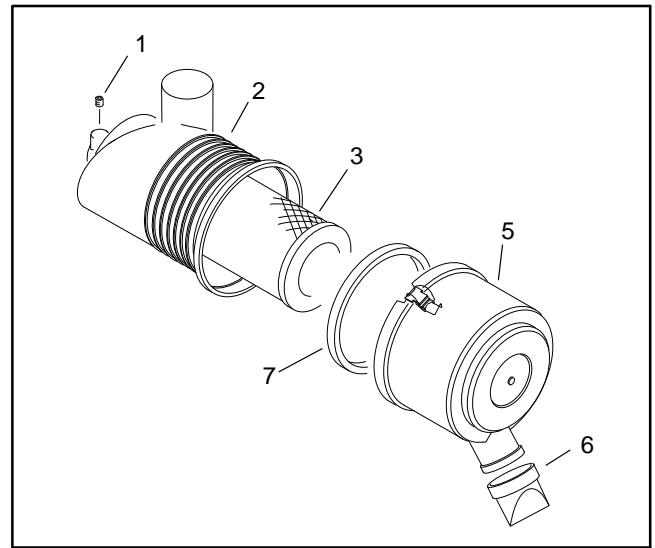

Figure 6

- |   |                         |
|---|-------------------------|
| 1. Plug                                   | 5. Cover                |
| 2. Body                                   | 6. Vacuator valve       |
| 3. Primary filter element                 | 7. Gasket (if equipped) |
| 4. Safety filter element<br>(if equipped) |                         |

# Exhaust System

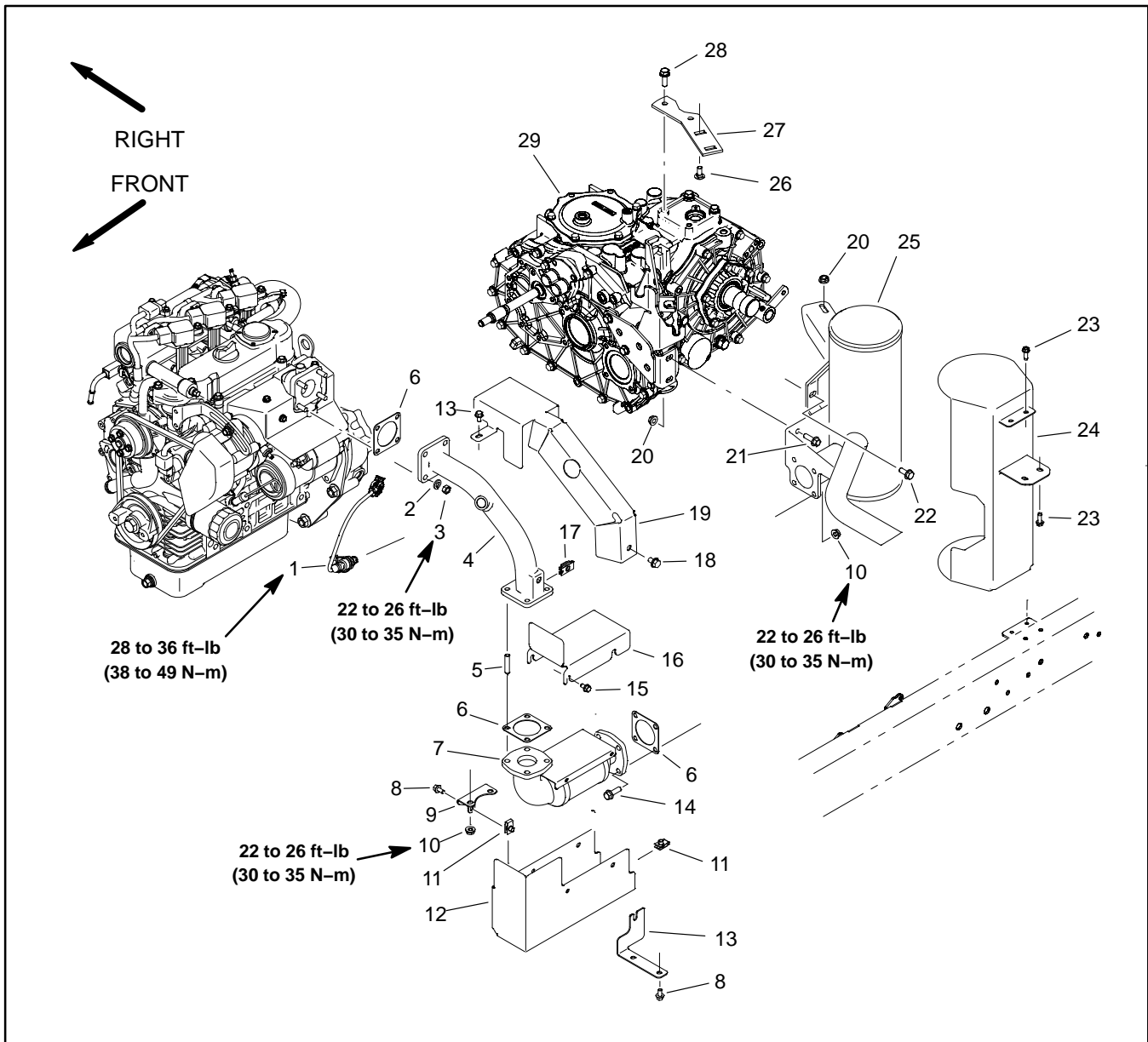

Figure 7

- |                        |                           |                           |
|------------------------|---------------------------|---------------------------|
| 1. Oxygen sensor       | 11. Retainer nut (3)      | 21. Flange head screw (2) |
| 2. Lock washer (4)     | 12. Heat shield           | 22. Flange head screw     |
| 3. Hex nut (4)         | 13. Heat shield mount     | 23. Flange head screw (4) |
| 4. Exhaust tube        | 14. Flange head screw (4) | 24. Heat shield           |
| 5. Stud (4)            | 15. Flange head screw (4) | 25. Muffler               |
| 6. Exhaust gasket (3)  | 16. Heat shield           | 26. Carriage bolt (2)     |
| 7. Catalytic converter | 17. Retainer nut          | 27. Mount plate           |
| 8. Flange head screw   | 18. Flange head screw     | 28. Flange head screw (2) |
| 9. Heat shield mount   | 19. Heat shield           | 29. Transaxle             |
| 10. Flange nut (8)     | 20. Flange nut (4)        |                           |

## Removal

1. Park vehicle on a level surface and engage parking brake. Stop the engine and remove key from ignition switch. Allow engine to cool.
2. Raise or remove the bed or other attachment(s). If bed is raised, place safety support on lift cylinder.
3. Note position of exhaust system heat shields and mounting brackets before removal. Remove exhaust system components as needed (Fig. 7).
4. Discard gaskets and thoroughly clean flange surfaces of exhaust tube, catalytic converter and muffler.

## Installation

1. Replace any removed gaskets.
2. Fit all exhaust components to vehicle before tightening any fasteners (Fig. 7). When securing exhaust, tighten fasteners in the following order:
  - A. Hex nuts that secure exhaust tube to engine. Torque from **22–26 ft–lbs (30 to 35 N–m)**.
  - B. Hex nuts that secure catalytic converter to exhaust tube. Torque from **22–26 ft–lbs (30 to 35 N–m)**.
  - C. Flange head screws and flange nuts that secure muffler to catalytic converter. Torque from **22–26 ft–lbs (30 to 35 N–m)**.
  - D. Flange head screw that secures muffler to trans-axle.
  - E. Flange head screws and flange nuts that secure muffler to shift cable mount bracket.
  - F. Carriage bolts and flange nuts that secure muffler to mount plate.
3. Install all exhaust system heat shields.

**NOTE:** If oxygen sensor was removed, torque sensor from **28 to 36 ft–lb (38 to 49 N–m)**.
4. Lower or install bed or attachment(s).

# Fuel System

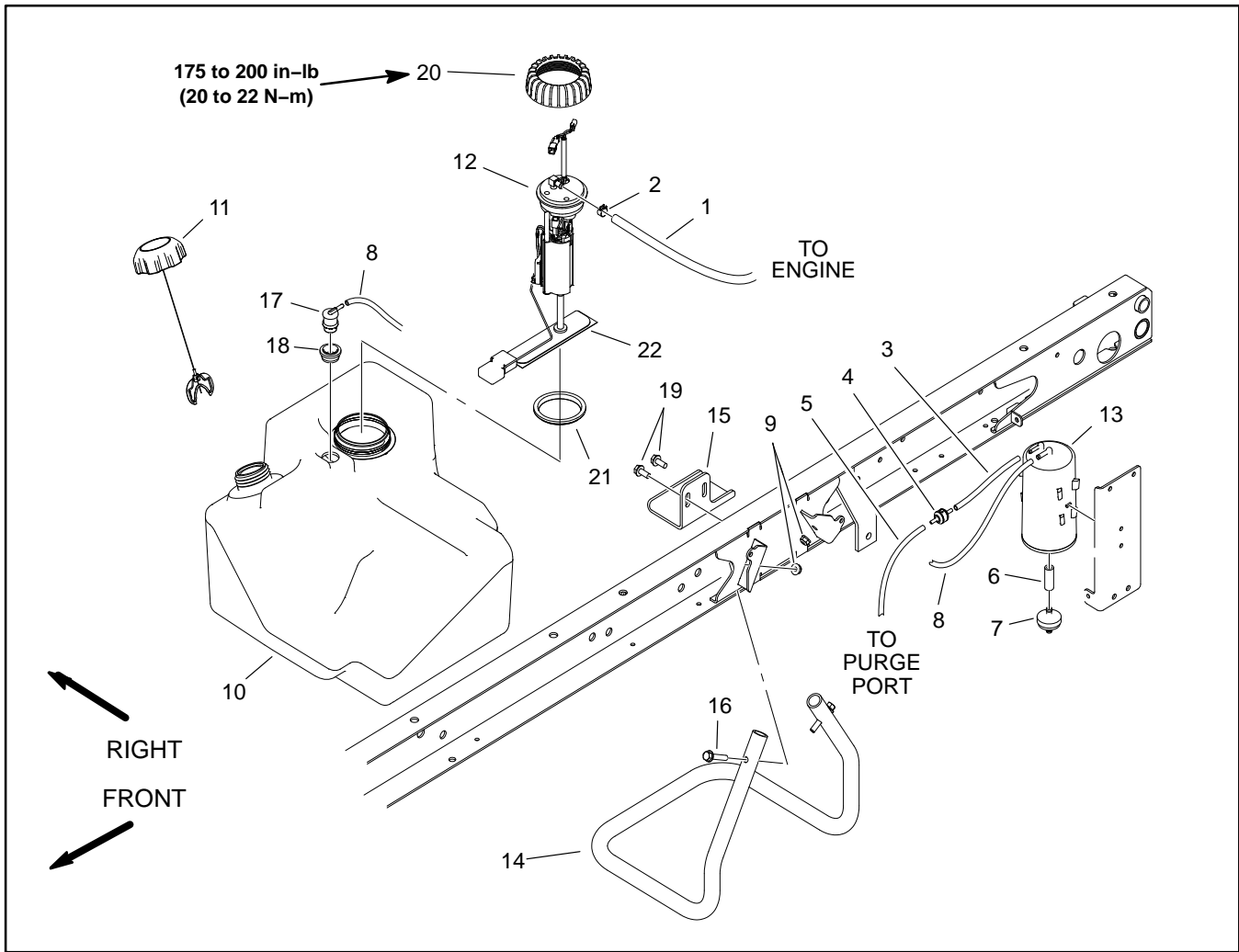



Figure 8

- |                                 |                               |                           |
|---------------------------------|-------------------------------|---------------------------|
| 1. Fuel hose (to engine)        | 9. Flange nut (2)             | 16. Washer head screw (2) |
| 2. Hose clamp                   | 10. Fuel tank                 | 17. Rollover valve        |
| 3. Fuel hose (to vacuum valve)  | 11. Fuel cap                  | 18. Grommet               |
| 4. Vacuum check valve           | 12. Fuel pump/sender assembly | 19. Washer head screw (2) |
| 5. Fuel hose (to engine)        | 13. Carbon canister           | 20. Cap                   |
| 6. Filter hose                  | 14. Support tube              | 21. Gasket                |
| 7. Canister filter              | 15. Retainer plate            | 22. Fuel filter           |
| 8. Fuel hose (tank to canister) |                               |                           |

DANGER

**Because gasoline is highly flammable, use caution when storing or handling it. Do not smoke while filling or servicing the fuel tank. Do not fill or service fuel tank while engine is running, hot or when vehicle is in an enclosed area. Always fill fuel tank outside and wipe up any spilled fuel before starting the engine. Store fuel in a clean, safety-approved container and keep cap in place. Use fuel for the engine only; not for any other purpose.**

## Check Fuel Lines and Connections

Check fuel lines and connections periodically as recommended in the Operator's Manual. Check lines for deterioration, damage, leaks or loose connections. Replace hoses, clamps and connections as necessary.



### Fuel Tank Removal (Fig. 8)

1. Park vehicle on a level surface and engage parking brake. Stop the engine and remove key from ignition switch. Allow engine to cool.
2. Raise or remove the bed or other attachment(s). If bed is raised, place safety support on lift cylinder.
3. Disconnect wire harness connectors from fuel pump and sender on fuel tank.

	<b>CAUTION</b>
<b>The fuel supply hose will contain pressurized fuel. Be careful when disconnecting supply hose. Wipe up any spilled fuel before starting the engine.</b>	

4. Note routing of fuel hoses for installation purposes (Fig. 9). Disconnect fuel supply hose from fuel pump/sender and tank vent hose from rollover valve. Plug fuel hoses to prevent leakage or system contamination.
5. Remove washer head screws and retainer plate that secure fuel tank.
6. Remove fuel tank from vehicle.

### Fuel Tank Installation (Fig. 8)

1. Position fuel tank to support tube on vehicle.
2. Remove plugs placed in fuel hoses during fuel tank removal. Connect fuel supply hose to fuel pump/sender and tank vent hose to rollover valve (Fig. 9). Secure fuel hoses with hose clamps.
3. Connect wire harness connectors to fuel pump and sender.
4. Position retainer plate to tank and frame. Make sure that fuel hoses are correctly placed under plate (Fig. 9). While pressing down on retainer plate to best retain tank, install and tighten washer head screws to secure fuel tank.
5. Lower or install the bed or other attachment(s).
6. Fill fuel tank. Check for fuel leakage and correct if found.

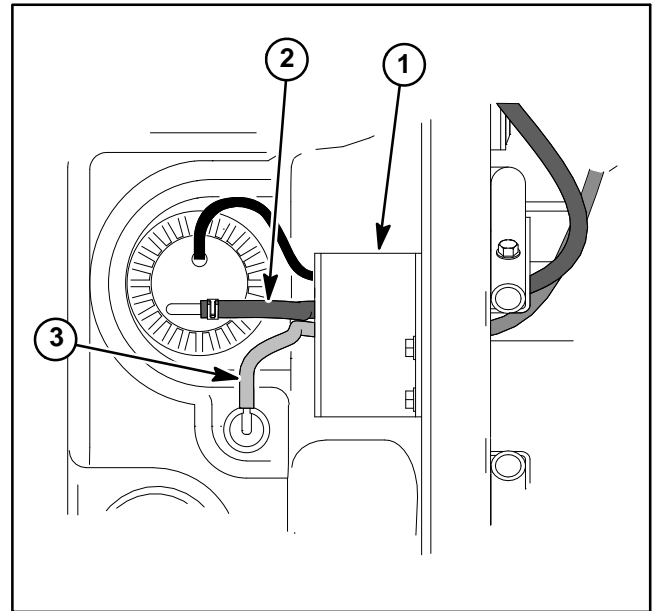

Figure 9

1. Retainer plate
2. Fuel supply hose
3. Tank vent hose

### Fuel Pump Removal (Fig. 8)

1. Park vehicle on a level surface, raise bed and engage parking brake. Stop the engine and remove key from ignition switch. Allow engine to cool.
2. Install bed support on bed lift cylinder to prevent bed from lowering.
3. Disconnect vehicle wire harness connectors from fuel pump/sender assembly on fuel tank.



## CAUTION

The fuel supply hose will contain pressurized fuel. Be careful when disconnecting fuel supply hose. Wipe up any spilled fuel before starting the engine.

4. Disconnect fuel supply hose from fuel pump/sender. Plug fuel hose to prevent leakage or system contamination.
  5. Note orientation of fuel fitting on fuel pump for assembly purposes.
  6. Remove cap that secures fuel pump/sender assembly in fuel tank.
- NOTE:** Do not allow fuel pump/sender assembly to rotate during removal or damage to the sender float arm may result.
7. Carefully remove fuel pump/sender and gasket from tank.

### Fuel Pump Installation (Fig. 8)

1. Make sure that fuel tank and fuel pump/sender gasket surfaces are thoroughly clean.
2. Position gasket to sealing surface of fuel pump/sender.
3. Carefully insert fuel pump/sender and gasket into tank. Orientate fuel fitting so that it is pointing toward the vehicle frame.
4. Secure fuel pump/sender to fuel tank with cap. Torque cap from **175 to 200 in-lb (20 to 22 N-m)**.
5. Remove plug placed in fuel supply hose and connect supply hose to fuel pump/sender. Secure fuel hose with hose clamp.
6. Connect vehicle wire harness connectors to fuel pump/sender assembly on fuel tank.
7. Remove bed support from lift cylinder and lower bed.

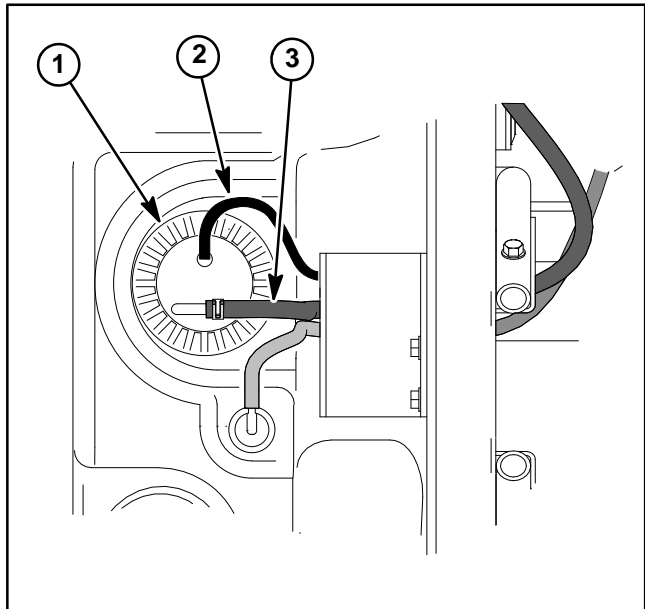

Figure 10

1. Fuel pump/sender
2. Wire harness
3. Fuel supply hose

## Carbon Canister

The function of the fuel evaporative control system is to collect and store evaporative emissions from the fuel tank and engine. A carbon canister that is mounted to the left side of the frame is used to collect these evaporative emissions. Fuel vapors from the engine and fuel tank are vented to the canister when the engine is not running. Vapors from the canister are consumed when the engine is running.

**NOTE:** If there is restriction in the canister breather, the carbon canister or the vacuum check valve, the fuel tank may distort due to venting issues. If the fuel tank returns to its normal shape when the fuel cap is removed, restriction in the evaporative control system is likely.

## Carbon Canister Removal

1. Park vehicle on a level surface, raise bed and engage parking brake. Stop the engine and remove key from ignition switch. Allow engine to cool.

**DANGER**

**Gasoline is flammable. Use caution when storing or handling it. Do not smoke while filling the fuel tank. Do not fill fuel tank while engine is running or in an enclosed area. Always fill fuel tank outside and wipe up any spilled fuel before starting the engine. Store fuel in a clean, safety-approved container and keep the cap in place. Use gasoline for the engine only; not for any other purpose.**

2. Inspect carbon cannister and attached hoses for damage or obvious leaks. A damaged or leaking cannister should be replaced.

3. Note hose routing, cable tie and anchor clamp locations. Remove fuel evaporative control system components as needed (Fig. 11).

## Carbon Canister Installation

1. Install all removed EVAP components. Make sure that fuel hoses are not kinked after installation. Secure all hoses with hose clamps, anchor clamps and cable ties as noted. If hoses were removed from the carbon canister, check hose connections for correct system operation (Fig. 11).

2. After all evaporative control system components are installed, remove bed support from lift cylinder and lower bed.

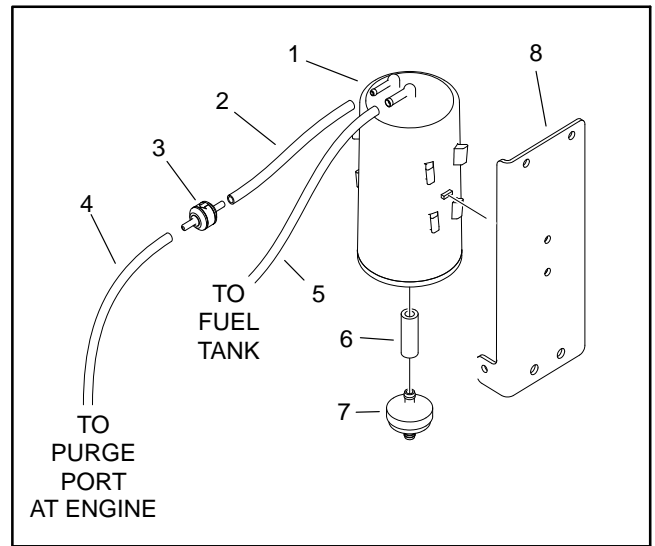

Figure 11

- |                          |                        |
|--------------------------|------------------------|
| 1. Carbon canister       | 5. Fuel hose (to tank) |
| 2. Fuel hose             | 6. Filter hose         |
| 3. Vacuum check valve    | 7. Canister filter     |
| 4. Fuel hose (to engine) | 8. Canister mount      |

# Radiator

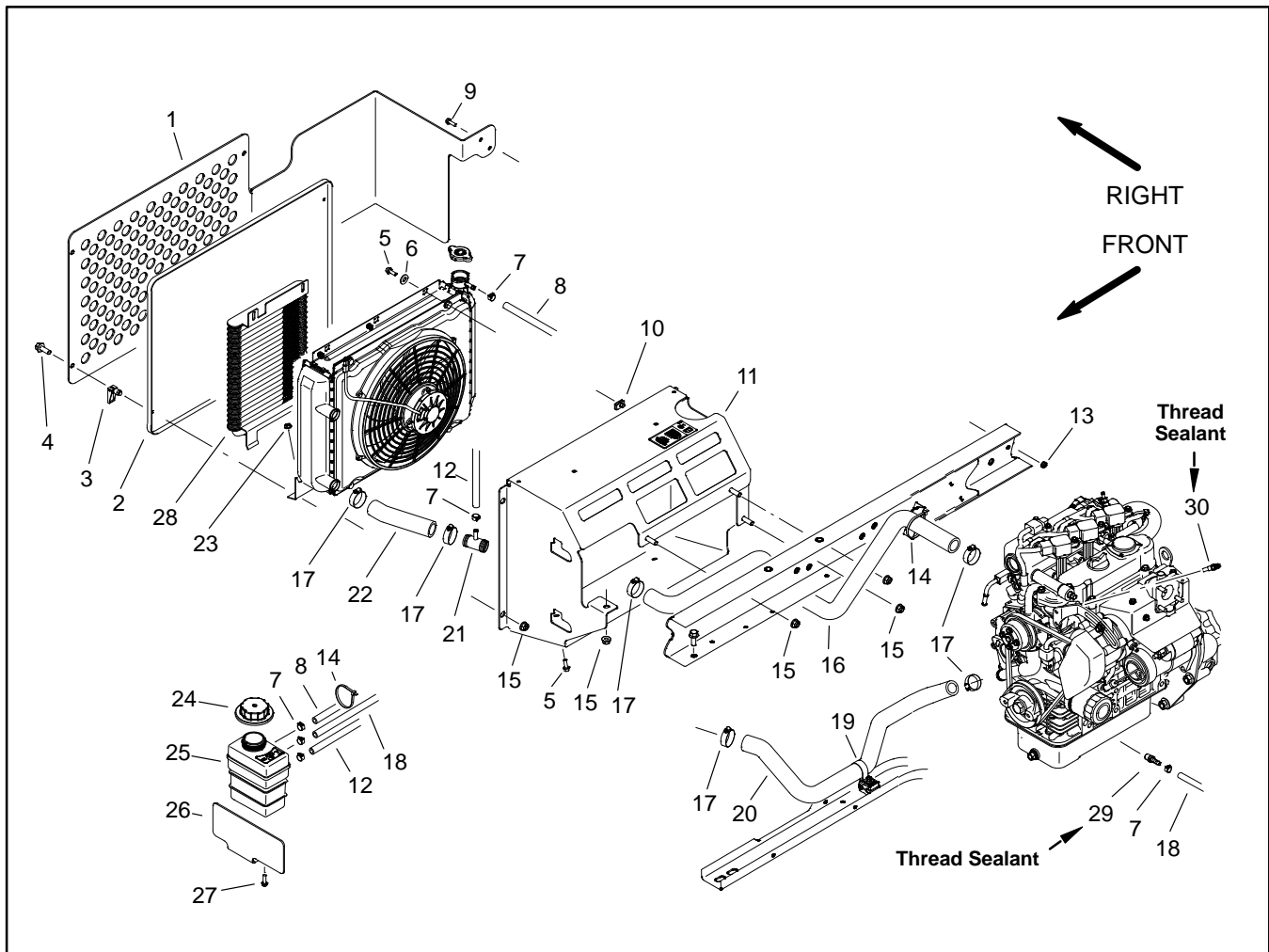



Figure 12

- |  |                                    |                           |
|--|------------------------------------|---------------------------|
| 1. Radiator guard (industrial)           | 10. Clip (2)                       | 21. Tee fitting           |
| 2. Radiator screen                       | 11. Radiator mount                 | 22. Lower radiator hose   |
| 3. Swell latch (4)                       | 12. Hose (lower hose to reservoir) | 23. Flange nut (2)        |
| 4. Flange head screw<br>(4 – industrial) | 13. Flange nut (4 – industrial)    | 24. Reservoir cap         |
| 5. Flange head screw (4)                 | 14. Cable tie                      | 25. Coolant reservoir     |
| 6. Flat Washer                           | 15. Flange nut (4)                 | 26. Reservoir mount       |
| 7. Hose clamp                            | 16. Upper radiator hose            | 27. Flange head screw (2) |
| 8. Hose (radiator to reservoir)          | 17. Hose clamp (6)                 | 28. Oil cooler (optional) |
| 9. Flange head screw<br>(2 – industrial) | 18. Hose (engine to reservoir)     | 29. Barb fitting          |
|  | 19. R-clamp (2)                    | 30. Temperature sensor    |
|  | 20. Lower radiator hose            |                           |

## Removal (Fig. 12)

1. Park vehicle on a level surface, stop engine, engage parking brake and remove key from the ignition switch. Allow engine and radiator to cool.
2. Raise or remove the bed or other attachment(s). If bed is raised, place safety support on lift cylinder.
3. Unlatch and remove radiator screen from front of radiator.
4. If vehicle is equipped with high flow hydraulics kit, rotate oil cooler latches and place oil cooler away from radiator.



## CAUTION

**Do not open radiator cap or drain coolant if the radiator or engine is hot. Pressurized, hot coolant can escape and cause burns.**

**Ethylene-glycol antifreeze is poisonous. Dispose of coolant properly or store it in a properly labeled container away from children and pets.**

5. Remove the radiator cap.
6. Drain radiator into a suitable container by disconnecting lower radiator hose from the radiator.
7. Disconnect upper radiator hose from the radiator.
8. Disconnect reservoir hose from the radiator filler neck.
9. Disconnect wire harness connector from radiator fan.
10. Detach radiator assembly from radiator mount:
  - A. Remove two (2) flange head screws and flat washers that secure the top of the radiator assembly to the mount.
  - B. Remove two (2) flange head screws and flange nuts that secure the bottom of the radiator assembly to the mount.
11. Carefully separate radiator assembly from mount and remove from vehicle.
12. Plug all radiator and hose openings to prevent contamination.
13. If necessary, remove components from radiator (Fig. 13).

## Installation (Fig. 12)

1. If radiator assembly was disassembled, install components to radiator using (Fig. 13) as a guide. Make sure that clearance exists between shroud and fan at all points.
2. Remove plugs from radiator openings and hoses placed during the removal procedure.
3. Position radiator assembly to the radiator mount. Secure radiator assembly to the vehicle with removed flange head screws, flat washers and flange nuts.
4. Connect reservoir hose to the radiator filler neck. Secure hose with hose clamp.
5. Connect upper and lower hoses to the radiator. Secure hoses with hose clamps.
6. Connect wire harness connector to radiator fan.
7. Fill radiator with coolant to the bottom of the filler neck.
8. If vehicle is equipped with high flow hydraulics kit, position oil cooler to radiator and secure in place.
9. Install and latch the radiator screen.
10. Lower or install bed or other attachment(s).

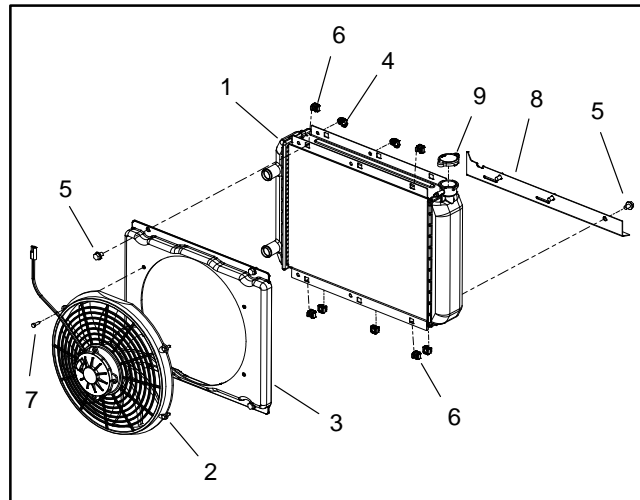

Figure 13

- |                           |                      |
|---------------------------|----------------------|
| 1. Radiator               | 6. Nut (7)           |
| 2. Electric fan           | 7. Screw (4)         |
| 3. Shroud                 | 8. Lower mount plate |
| 4. Latch (2 – oil cooler) | 9. Radiator cap      |
| 5. Flange screw (7)       |                      |

# Engine

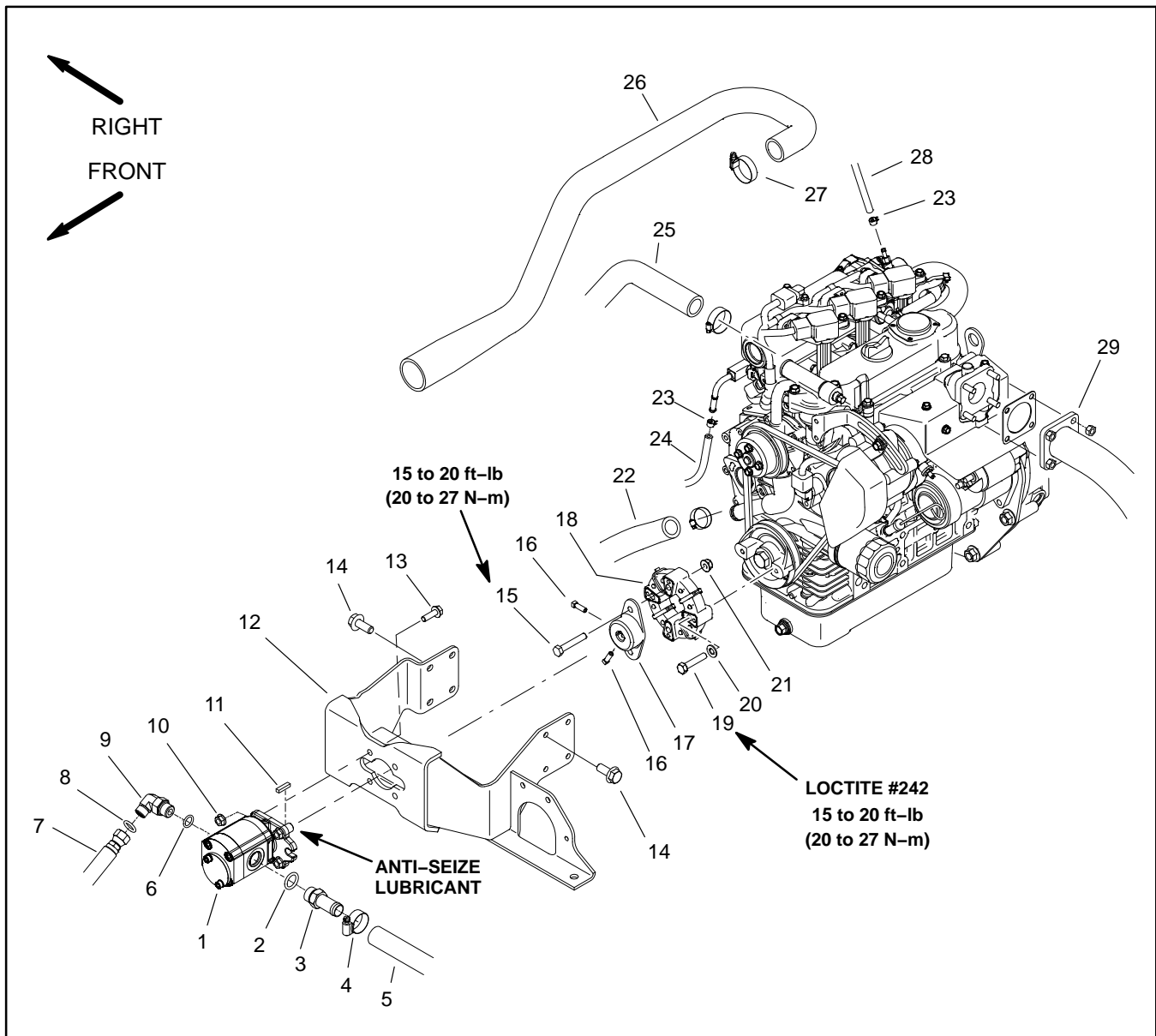

Figure 14

- |   |   |   |
|---|---|---|
| <ul style="list-style-type: none"> <li>1. Gear pump</li> <li>2. O-ring</li> <li>3. Hydraulic fitting</li> <li>4. Hose clamp</li> <li>5. Suction hose (from transaxle)</li> <li>6. O-ring</li> <li>7. Hose (to lift valve)</li> <li>8. O-ring</li> <li>9. Hydraulic fitting</li> <li>10. Flange nut (4)</li> </ul> | <ul style="list-style-type: none"> <li>11. Square key</li> <li>12. Pump/engine mount</li> <li>13. Flange head screw (4)</li> <li>14. Flange head screw (8)</li> <li>15. Hex head screw (2)</li> <li>16. Square head screw (2)</li> <li>17. Pump hub</li> <li>18. Coupling</li> <li>19. Hex head screw (2)</li> <li>20. Flat washer (2)</li> </ul> | <ul style="list-style-type: none"> <li>21. Hex flange nut (2)</li> <li>22. Lower radiator hose</li> <li>23. Hose clamp</li> <li>24. Fuel supply hose</li> <li>25. Upper radiator hose</li> <li>26. Air intake hose</li> <li>27. Hose clamp</li> <li>28. Return fuel hose</li> <li>29. Exhaust tube</li> </ul> |
|---|---|---|

## Engine Removal (Fig. 14)

1. Park vehicle on a level surface and engage parking brake. Stop the engine and remove key from ignition switch. Allow engine to cool.

2. Raise or remove the bed or other attachment(s) to gain access to engine. If bed is raised, place safety support on lift cylinder.

3. Disconnect negative (-) and then positive (+) battery cables at the battery.

4. Remove exhaust tube from vehicle (see Exhaust System Removal in this section).

5. Loosen hose clamp that secures air intake hose to engine. Remove intake hose from engine.

6. Disconnect fuel supply and return hoses from fuel injection pump on engine. Plug end of fuel hoses to prevent contamination and fuel spillage. Position disconnected fuel hoses away from engine.

7. Note location of cable ties used to secure wire harness leads. Label and disconnect wire harness connectors that attach to engine:

A. Positive (+) battery cable, fusible link harness and harness ring terminal from starter solenoid stud (Fig. 12).

B. Wire from spade terminal on starter solenoid.

C. Wire from oil pressure switch.

D. Wires from temperature sender and thermal fan switch on water pump housing.

E. Harness connector and wire with ring terminal from alternator.

F. Negative (-) battery cable and harness ground connector secured to engine mount (Fig. 15). Note location of ground connections and flange head screw for assembly purposes.

G. Harness connector with ring terminal from glow plug connector.

H. Harness connector from fuel solenoid on injection pump.

I. Harness connector from crankshaft sensor.

8. Disconnect accelerator cable from throttle lever and cable support bracket. Position accelerator cable away from engine.

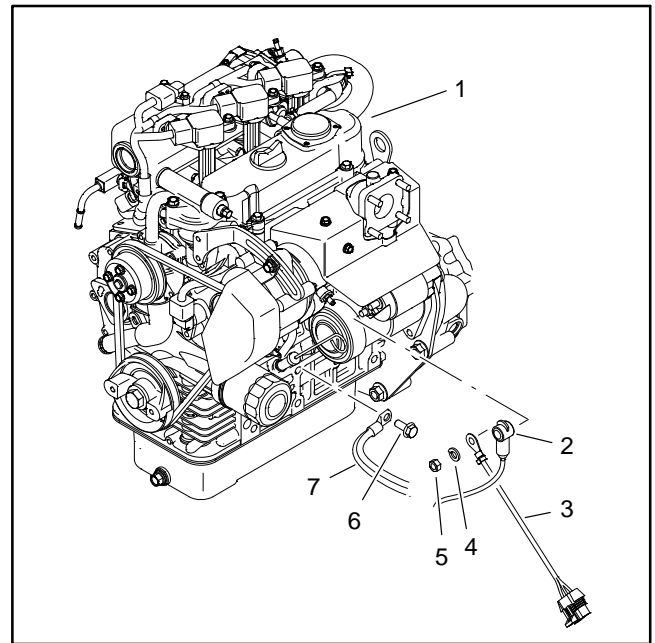

Figure 15

- |                         |                          |
|-------------------------|--------------------------|
| 1. Engine               | 5. Hex nut               |
| 2. Positive cable       | 6. Flange head screw     |
| 3. Fusible link harness | 7. Negative/ground cable |
| 4. Lock washer          |                          |

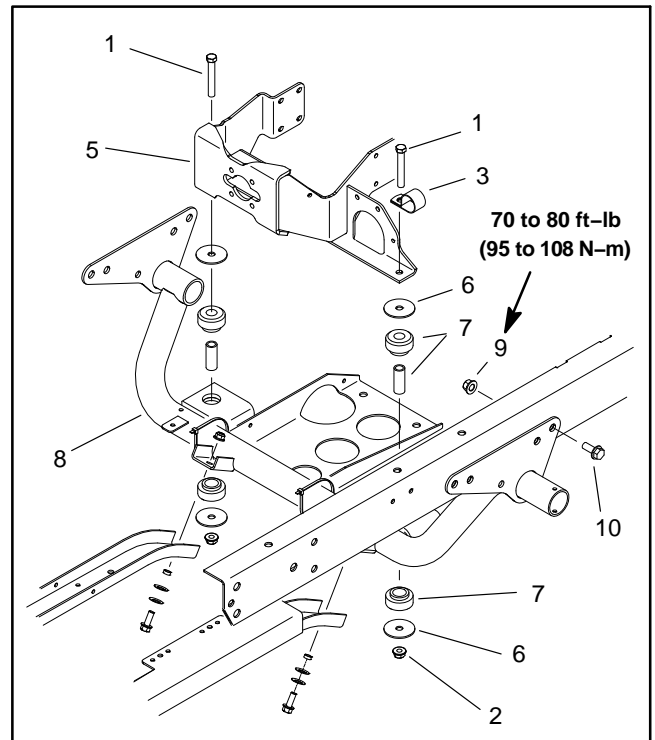

Figure 16

- |                   |                           |
|-------------------|---------------------------|
| 1. Cap screw      | 6. Snubbing washer        |
| 2. Flange nut     | 7. Engine mount assembly  |
| 3. R-clamp        | 8. Engine support         |
| 4. Engine support | 9. Flange nut (8)         |
| 5. Engine mount   | 10. Flange head screw (8) |



## CAUTION

**Do not open radiator cap or drain coolant if the radiator or engine is hot. Pressurized, hot coolant can escape and cause burns.**

**Ethylene-glycol antifreeze is poisonous. Dispose of coolant properly or store it in a properly labeled container away from children and pets.**

9. Remove the radiator cap. Drain radiator into a suitable container by disconnecting lower radiator hose from the radiator.

10. Loosen hose clamps and remove upper and lower radiator hoses from engine. Remove R-clamp that secures lower radiator hose to engine mount. Position radiator hoses away from engine.

11. Remove all clamps and cable ties used to attach wiring harness, hoses or cables to the engine.

12. On 4WD vehicles, remove differential drive shaft (see Differential Driveshaft in Chapter 10 – Front Wheel Drive (4WD)).



## CAUTION

**Before performing any service or repair on hydraulic system components, relieve system pressure to avoid injury from pressurized hydraulic oil. Rotate the steering wheel in both directions, make sure that the bed is lowered onto the bed support and operate any other hydraulic accessories.**

13. Thoroughly clean junction of gear pump fittings and hydraulic hoses. Label hydraulic hoses for assembly purposes. Disconnect hydraulic hoses from gear pump. Install caps or plugs in hoses and pump fittings to prevent contamination and leakage of hydraulic oil.

14. Put blocking under transaxle to prevent the transaxle from moving during engine removal.

15. Loosen and remove two (2) flange nuts, snubbing washers and cap screws that secure engine mounts to engine support (Fig. 16).

16. Remove six (6) cap screws that secure clutch bell housing to engine. Note location of harness bracket(s) (Fig. 17).

17. Use engine lifting lugs provided and a hoist or lift to remove engine from chassis. One person should operate hoist or lift and a second person should help guide engine out of chassis. Move engine forward before lifting to disengage transaxle input shaft from clutch.

18. Note location and retrieve two (2) dowel pins from bell housing (Fig. 17).

19. If necessary, remove gear pump from engine mount (see Gear Pump Removal in Chapter 9 – Hydraulic System).

20. If necessary, remove engine mount from engine.

21. If necessary, remove coupler components from engine pulley.

22. If necessary, remove pressure plate and clutch disc (see Clutch Disassembly and Inspection in Chapter 6 – Drive Train).

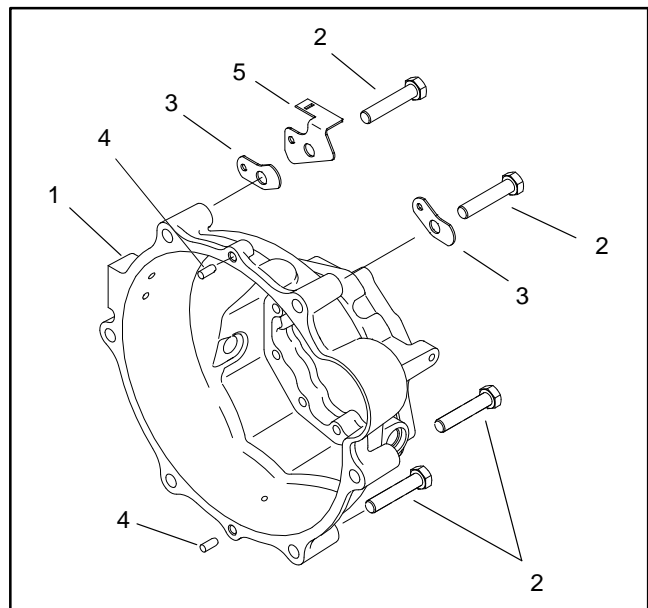

Figure 17

- |                    |                    |
|--------------------|--------------------|
| 1. Bell housing    | 4. Dowel pins (2)  |
| 2. Cap screw (6)   | 5. Harness bracket |
| 3. Harness bracket |                    |



## Engine Installation (Fig. 14)

1. Install pressure plate and clutch disc if removed (see Installing Clutch Disc and Cover in Chapter 6 – Drive Train).
2. If coupler assembly was removed, assemble coupler to engine pulley. Apply Loctite #242 (or equivalent) to threads of flange head screws that secure coupler to engine pulley. Torque fasteners to **15 to 20 ft-lb (20 to 27 N-m)**.
3. If engine mount was removed, secure mount to engine with seven (7) flange head screws. Do not install the screw used to secure the ground connections to the engine at this time.
4. If gear pump was removed, install gear pump to engine mount (see Gear Pump Installation in Chapter 9 – Hydraulic System in this manual).
5. Install two (2) dowel pins in bell housing bores (Fig. 14).
6. Make sure that snubbing washer is positioned on top of both engine mounts (Fig. 13).
7. Apply anti-seize lubricant to splines on transaxle input shaft.
8. Use engine lifting lugs provided and a hoist or lift to install engine to chassis. One person should operate hoist and second person should help guide engine to machine. Align splines on transaxle input shaft and clutch while moving engine to bell housing on transaxle.
9. Secure bell housing to engine with six (6) cap screws and harness bracket(s) (Fig. 17).
10. Secure engine mount to engine support with two (2) cap screws, snubbing washers and flange nuts (Fig. 16).
11. Remove plugs from hydraulic hoses and gear pump fittings. Connect hydraulic hoses to gear pump (see Hydraulic Hose and Tube Installation in Chapter 9 – Hydraulic System).
12. On 4WD vehicles, install differential drive shaft (see Differential Driveshaft Installation in Chapter 10 – Front Wheel Drive (4WD)).
13. Install upper and lower radiator hoses to engine and secure with hose clamps. Install R-clamp to secure lower radiator hose to engine mount.
14. Fill radiator with coolant (see vehicle Operator's Manual).
15. Connect wire harness connectors to engine components. Secure wire harness to machine with cable ties in locations noted during engine removal.
  - A. Positive (+) battery cable, fusible link harness and harness ring terminal from starter solenoid stud (Fig. 12).
  - B. Wire from spade terminal on starter solenoid.
  - C. Wire from oil pressure switch.
  - D. Wires from temperature sender and thermal fan switch on water pump housing.
  - E. Harness connector and wire with ring terminal from alternator.
  - F. Negative (-) battery cable and harness ground connector secured to engine mount (Fig. 15). Note location of ground connections and flange head screw for assembly purposes.
  - G. Harness connector with ring terminal from glow plug connector.
  - H. Harness connector from fuel solenoid on injection pump.
  - I. Harness connector from crankshaft sensor.
16. Secure accelerator cable to throttle lever on engine and cable support bracket.
17. Install air intake hose to engine and secure with hose clamp.
18. Connect fuel supply and return hoses to fuel injection pump on engine. Secure hoses with hose clamps.
19. Install exhaust tube to vehicle (see Exhaust System Installation in this section).
20. Connect positive (+) and then negative (-) battery cables to the battery.
21. Check operation and adjustment of accelerator pedal (see Adjust Accelerator Cable in this chapter).

This page is intentionally blank.



# Kubota Diesel Engine

## Table of Contents

SPECIFICATIONS .....	2
GENERAL INFORMATION .....	3
Operator's Manual .....	3
ADJUSTMENTS .....	4
Adjust Accelerator Cable .....	4
SERVICE AND REPAIRS .....	6
Air Cleaner System .....	6
Exhaust System .....	8
Fuel System .....	10
Fuel Tank .....	11
Fuel Sender .....	11
Radiator .....	12
Engine .....	14
KUBOTA WORKSHOP MANUAL, DIESEL ENGINE, SM-E3B SERIES	

Kubota  
Diesel Engine

# Specifications

Item	Description
Make / Designation	Kubota water-cooled, Diesel, Model D902-E3B
Number of Cylinders	3
Bore x Stroke	2.83" x 2.9" (72mm x 73.6mm)
Total Displacement	54.8 in <sup>3</sup> (898 cc)
Compression Ratio	24.0:1
Firing Order	1 (front) – 2 – 3
Direction of Rotation	Counterclockwise (viewed from flywheel)
Fuel	Diesel or Biodiesel (up to B20) Fuel with Low or Ultra Low Sulfur Content
Fuel Injector Pump	Bosch MD Type Mini
Fuel Injection Nozzle	Bosch Throttle Type
Fuel Capacity	6 U.S. gallons (22.8 liters)
Governor	Centrifugal Mechanical
Low Idle (no load)	1500 ± 50 RPM
High Idle (no load)	3670 ± 50 RPM
Engine Oil	API CH-4, CI-4 or higher
Engine Oil Viscosity	See Operator's Manual
Oil Pump	Gear Driven Trochoid Type
Crankcase Oil Capacity	3.5 U.S. quarts (3.3 liters) with filter
Cooling System Capacity (including reserve tank)	3.7 U.S. quarts (3.5 liters)
Starter	12 VDC 1.2 KW
Alternator/Regulator	12 VDC 60 AMP

# General Information

Information about specifications, maintenance, troubleshooting, testing and repair of the diesel engine used in the Workman HDX-D is included in this chapter and the Kubota Workshop Manual, Diesel Engine, SM-E3B Series.

Most engine repairs and adjustments require tools which are commonly available in many service shops. Special tools are described in the Kubota Workshop Manual. The use of some specialized test equipment is explained. However, the cost of the test equipment and the specialized nature of some repairs may dictate that the work be done at an engine repair facility.

Service and repair parts for Kubota engines are supplied through your local local Toro distributor. If no parts list is available, be sure to provide your distributor with the Toro model and serial number.

---

## Operator's Manual

The Operator's Manual provides information regarding the operation, general maintenance and maintenance intervals for your Workman HDX-D vehicle. Refer to the Operator's Manual for additional information when servicing the vehicle.

# Adjustments

## Adjust Accelerator Cable

1. Position the machine on a level surface, stop the engine, and engage the parking brake.
2. Check position of the engine speed control lever on fuel injection pump. The speed control lever should be contacting the high speed stop screw when the accelerator pedal arm is **.200" to .350" (5.08 mm to 8.89 mm)** above the floor plate (Fig. 1).
3. If necessary, throttle control can be adjusted by loosening cable jam nuts and repositioning throttle cable as necessary. There is no adjustment at the engine high speed stop bolt. Tighten cable jam nuts after adjustment has been completed (Fig.2).
4. Start engine and allow it to come to normal operating temperature.
5. Verify with a phototach that the **engine high speed** is **3670 ± 50 RPM** when the accelerator is fully depressed.
6. Verify with a phototach that the **engine low speed** is **1450 ± 50 RPM** when the accelerator is released.
7. Adjust idle stop bolt at accelerator pedal to assure the cable is loose enough to allow the engine throttle arm to fully return to idle (Fig. 3). There is no adjustment at the engine low speed stop bolt.

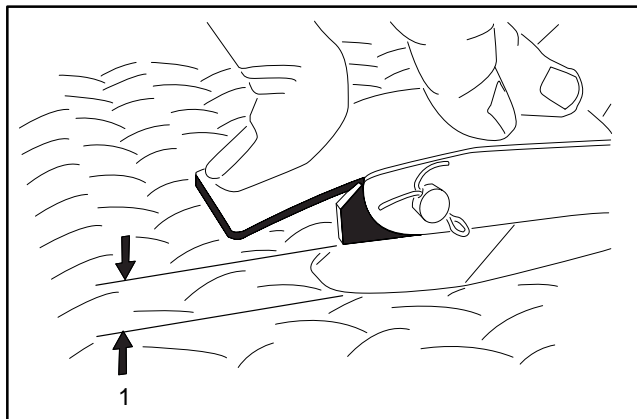

Figure 1

1. **.200" to .350" (5.08mm to 8.79mm)**

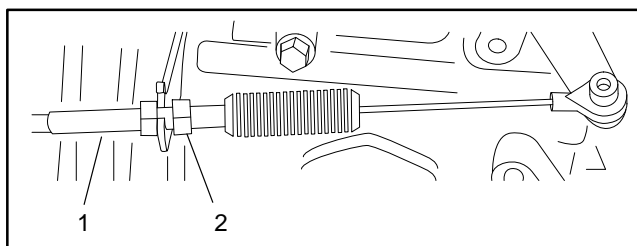

Figure 2

1. Throttle cable                      2. Jam nut

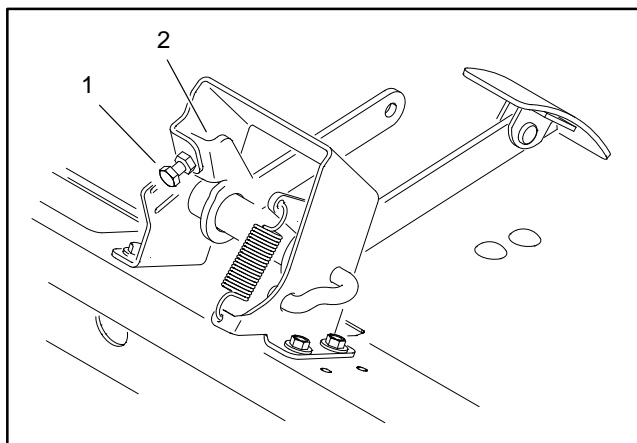

Figure 3

1. Idle stop bolt                      2. Accelerator pedal arm

This page is intentionally blank.

# Service and Repairs

## Air Cleaner System

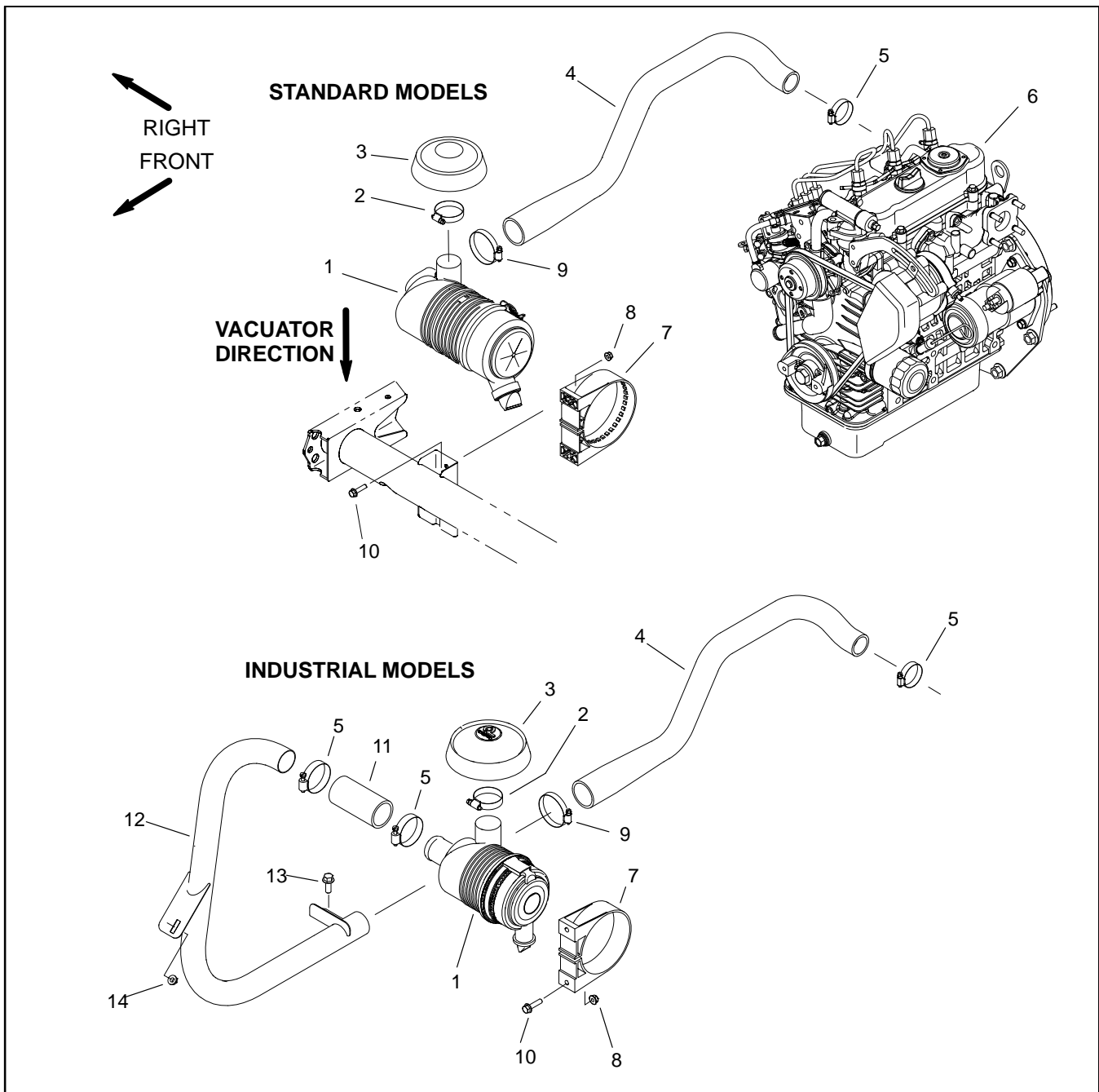

Figure 4

- 1. Air cleaner assembly
- 2. Hose clamp
- 3. Air inlet hood
- 4. Air intake hose
- 5. Hose clamp

- 6. Kubota diesel engine
- 7. Mounting bracket
- 8. Flange nut (2)
- 9. Hose clamp
- 10. Flange head screw (2)

- 11. Hose intake
- 12. Tube assembly
- 13. Flange head screw
- 14. Flange nut



## Air Cleaner Removal

1. Park vehicle on a level surface and engage parking brake. Stop the engine and remove key from ignition switch. Allow engine to cool.
2. Raise or remove the bed or other attachment(s) if necessary. If bed is raised, place safety support on lift cylinder.
3. Remove air cleaner components as needed.

## Air Cleaner Replacement

1. Undo latches and remove the air cleaner cover.
2. Clean the inside of the air cleaner cap and body with compressed air.
3. Gently slide the primary filter out of the air cleaner body (Fig. 5). Avoid knocking the filter into the side of the body.
4. Remove the safety filter (if equipped) only if you intend to replace it.

**IMPORTANT: Do Not attempt to clean the filter element(s). The elements are designed for replacement only. If the safety filter is dirty, the primary filter is damaged and you should replace both filters.**

5. Inspect the filter(s) for damage by looking into the filter while shining a bright light on the outside of the filter. Holes in the filter will appear as bright spots. Inspect the element for tears, an oily film, or damage to the rubber seal. If the filter is damaged do not use it.

	<b>CAUTION</b>
<b>To prevent engine damage, always operate the engine with air filter element(s) and cover installed</b>	

6. If you are replacing the safety filter, carefully slide the new filter into the filter body (Fig. 5).

7. Carefully slide the primary filter over the safety filter. Ensure that it is fully seated by pushing on the outer rim of the filter while installing it.

8. Install the air cleaner cover.

## Air Cleaner Installation

**IMPORTANT: Any leaks in the air filter system will cause serious engine damage. Make sure that all air cleaner components are in good condition and are properly secured during reassembly.**

1. Assemble air cleaner system (Fig. 4). Air cleaner inlet hood should be positioned straight upward. The vacuator valve on the air cleaner assembly should be positioned downward.
2. Lower or install bed or attachment(s).

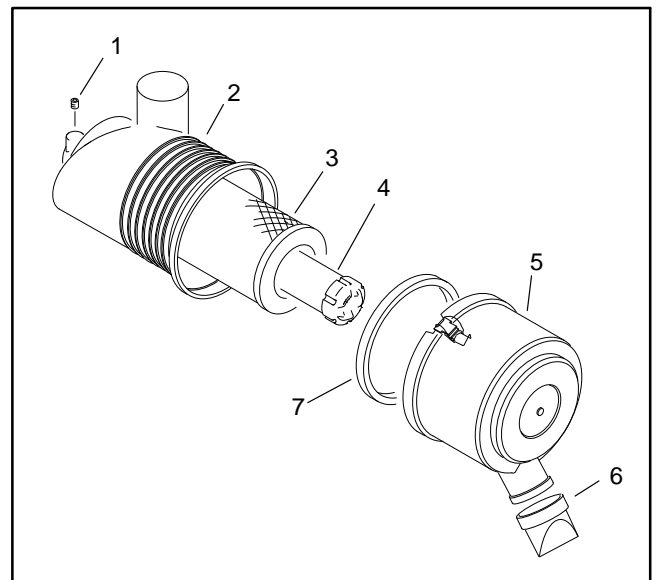

Figure 5

- |  |                         |
|--|-------------------------|
| 1. Plug                                | 5. Cover                |
| 2. Body                                | 6. Vacuator valve       |
| 3. Primary filter element              | 7. Gasket (if equipped) |
| 4. Safety filter element (if equipped) |                         |

# Exhaust System

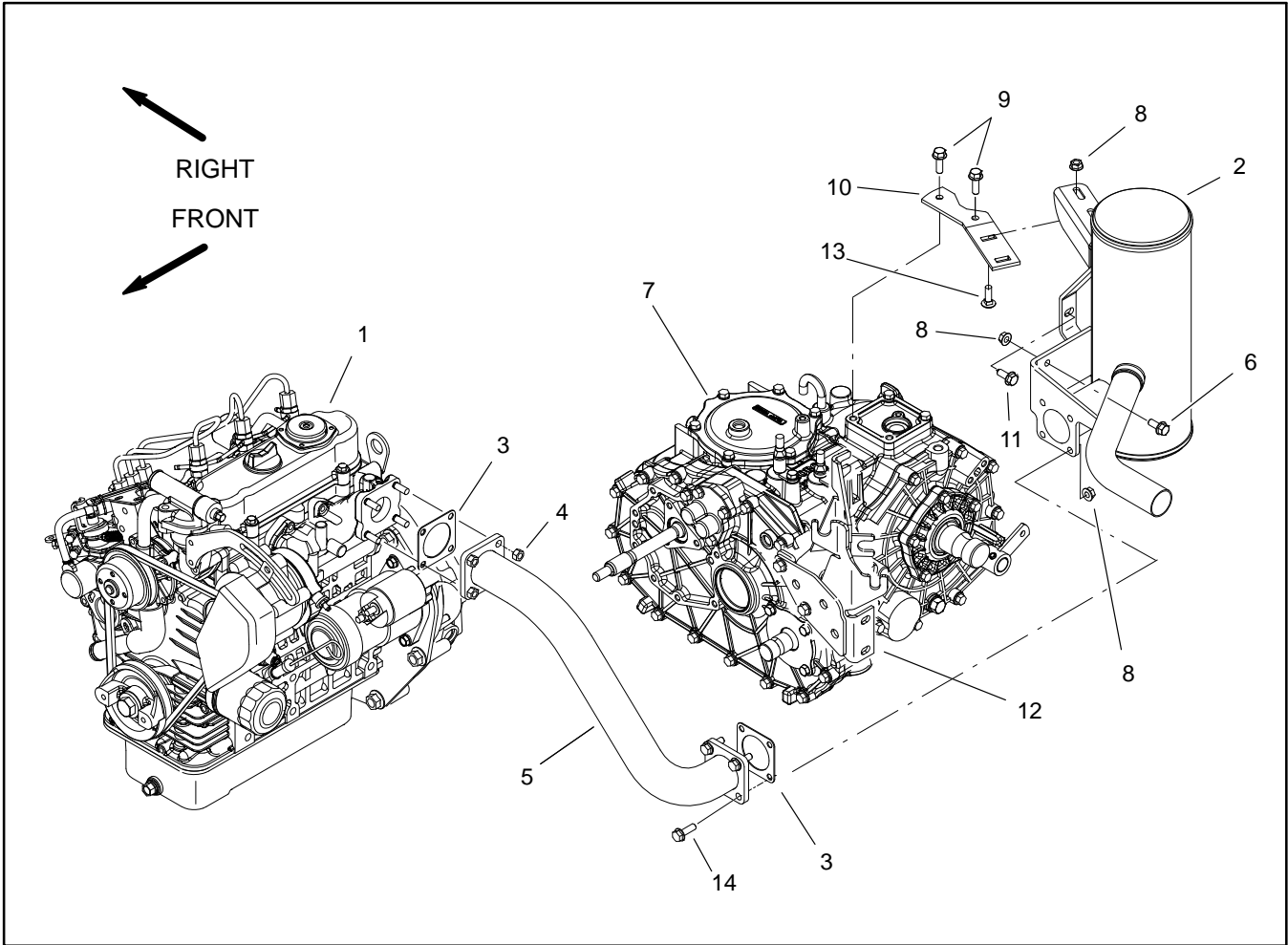

Figure 6

- |                   |                      |                               |
|-------------------|----------------------|-------------------------------|
| 1. Engine         | 6. Flange head screw | 11. Flange head screw         |
| 2. Muffler        | 7. Transaxle         | 12. Shift cable mount bracket |
| 3. Exhaust gasket | 8. Flange nut        | 13. Carriage bolt             |
| 4. Hex nut        | 9. Flange head screw | 14. Flange head screw         |
| 5. Exhaust tube   | 10. Mount plate      |                               |

### Removal (Fig. 6)

1. Park vehicle on a level surface and engage parking brake. Stop the engine and remove key from ignition switch. Allow engine to cool.
2. Raise or remove the bed or other attachment(s). If bed is raised, place safety support on lift cylinder.
3. Remove exhaust system components as needed.
4. Discard gaskets and thoroughly clean flange surfaces of exhaust tube and muffler.

### Installation (Fig. 6)

1. Replace any removed gaskets.
2. Fit all exhaust components to vehicle before tightening any fasteners. When securing exhaust, tighten fasteners in the following order:
  - A. Hex nuts that secure exhaust tube to engine.
  - B. Flange head screws and flange nuts that secure muffler to exhaust tube.
  - C. Flange head screw that secures muffler to trans-axle.
  - D. Flange head screws and flange nuts that secure muffler to shift cable mount bracket.
  - E. Carriage bolts and flange nuts that secure muffler to mount plate.
3. Lower or install bed or attachment(s).

## Fuel System

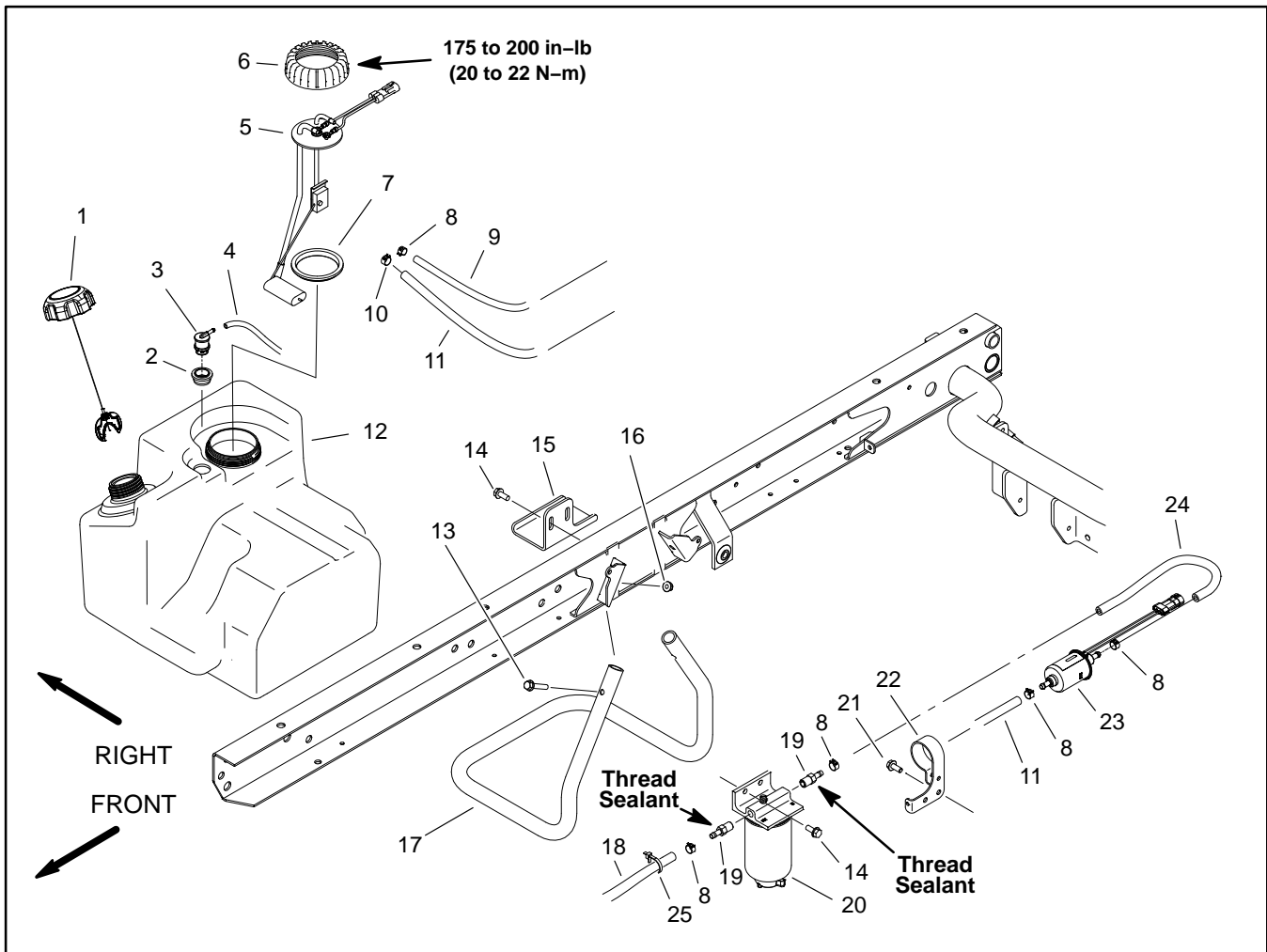

Figure 7

- |                     |                              |  |
|---------------------|------------------------------|--|
| 1. Fuel tank cap    | 10. Hose clamp               | 18. Fuel hose (filter/separator to engine) |
| 2. Grommet          | 11. Fuel hose (tank to pump) | 19. Fitting                                |
| 3. Rollover valve   | 12. Fuel tank                | 20. Fuel filter/water separator            |
| 4. Fuel hose (vent) | 13. Washer head screw        | 21. Washer head screw                      |
| 5. Fuel sender      | 14. Washer head screw        | 22. Fuel pump clamp                        |
| 6. Fuel sender nut  | 15. Retainer plate           | 23. Fuel pump                              |
| 7. Gasket           | 16. Flange nut               | 24. Fuel hose (pump to filter/separator)   |
| 8. Hose clamp       | 17. Support tube             | 25. Tie wrap                               |



## DANGER

Because diesel fuel is highly flammable, use caution when storing or handling it. Do not smoke while filling the fuel tank. Do not fill fuel tank while engine is running, hot or when vehicle is in an enclosed area. Always fill fuel tank outside and wipe up any spilled fuel before starting the engine. Store fuel in a clean, safety-approved container and keep cap in place. Use fuel for the engine only; not for any other purpose.

### Check Fuel Lines and Connections

Check fuel lines and connections periodically as recommended in the Operator's Manual. Check lines for deterioration, damage, leaks or loose connections. Replace hoses, clamps and connections as necessary.

### Fuel Tank Removal (Fig. 7)

1. Park vehicle on a level surface and engage parking brake. Stop the engine and remove key from ignition switch. Allow engine to cool.
2. Raise or remove the bed or other attachment(s). If bed is raised, place safety support on lift cylinder.
3. Disconnect wire harness connector from fuel sender on fuel tank.
4. Note routing of fuel hoses for installation purposes (Fig. 8). Disconnect fuel hoses from fuel sender and rollover valve. Plug fuel hoses to prevent leakage or fuel contamination.
5. Remove washer head screws and retainer plate that secure fuel tank.
6. Remove fuel tank from vehicle.

### Fuel Tank Installation (Fig. 7)

1. Position fuel tank to support tube.
2. Remove plugs placed in fuel hoses during fuel tank removal. Connect fuel hoses to fuel sender and rollover valve. Secure fuel hoses with hose clamps.
3. Connect wire harness connector to fuel sender.
4. Position retainer plate to tank and frame. Make sure that fuel hoses are correctly routed under retainer plate. Secure the fuel tank by pressing down on retainer plate while installing and tightening washer head screws.
5. Lower or install the bed or other attachment(s).
6. Fill fuel tank. Check for fuel leakage and correct if found.

### Fuel Sender Removal (Fig. 7)

1. Park vehicle on a level surface, raise bed and engage parking brake. Stop the engine and remove key from ignition switch. Allow engine to cool.
2. Install bed support on bed lift cylinder to prevent bed from lowering.
3. Disconnect vehicle wire harness connectors from fuel sender assembly on fuel tank.
4. Disconnect fuel hoses from fuel sender. Plug fuel hoses to prevent leakage or system contamination.
5. Note orientation of fuel fittings on fuel sender for assembly purposes.

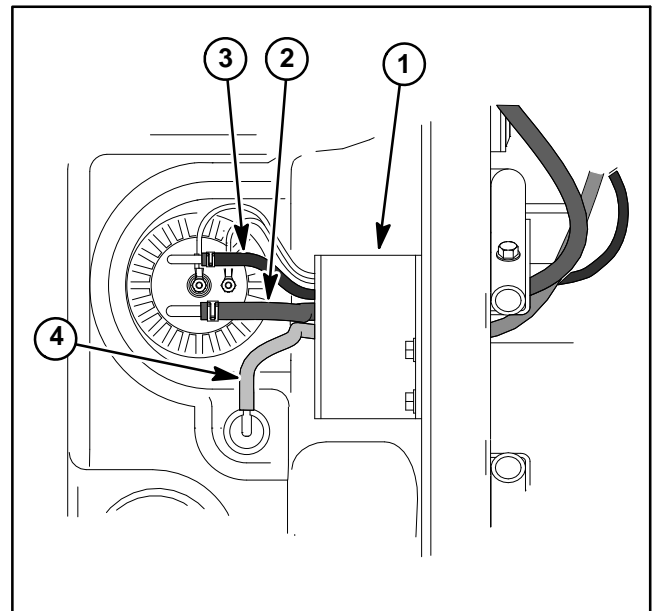

Figure 8

- |                     |                     |
|---------------------|---------------------|
| 1. Retainer plate   | 3. Fuel return hose |
| 2. Fuel supply hose | 4. Tank vent hose   |

6. Remove cap that secures fuel sender assembly in fuel tank.

**NOTE:** Do not allow fuel sender assembly to rotate during removal or damage to the sender float arm may result.

7. Carefully remove fuel sender and gasket from tank.

### Fuel Sender Installation (Fig. 7)

1. Make sure that fuel tank and fuel sender gasket surfaces are thoroughly clean.
2. Position gasket to sealing surface of fuel sender.
3. Carefully insert fuel sender and gasket into tank. Orientate fuel fittings so that it is pointing toward the vehicle frame.
4. Secure fuel sender to fuel tank with cap. Torque cap from **175 to 200 in-lb (20 to 22 N-m)**.
5. Remove plugs placed in fuel hoses and connect hoses to fuel sender. Secure fuel hoses with hose clamps.
6. Connect vehicle wire harness connectors to fuel sender assembly on fuel tank.
7. Remove bed support from lift cylinder and lower bed.

# Radiator

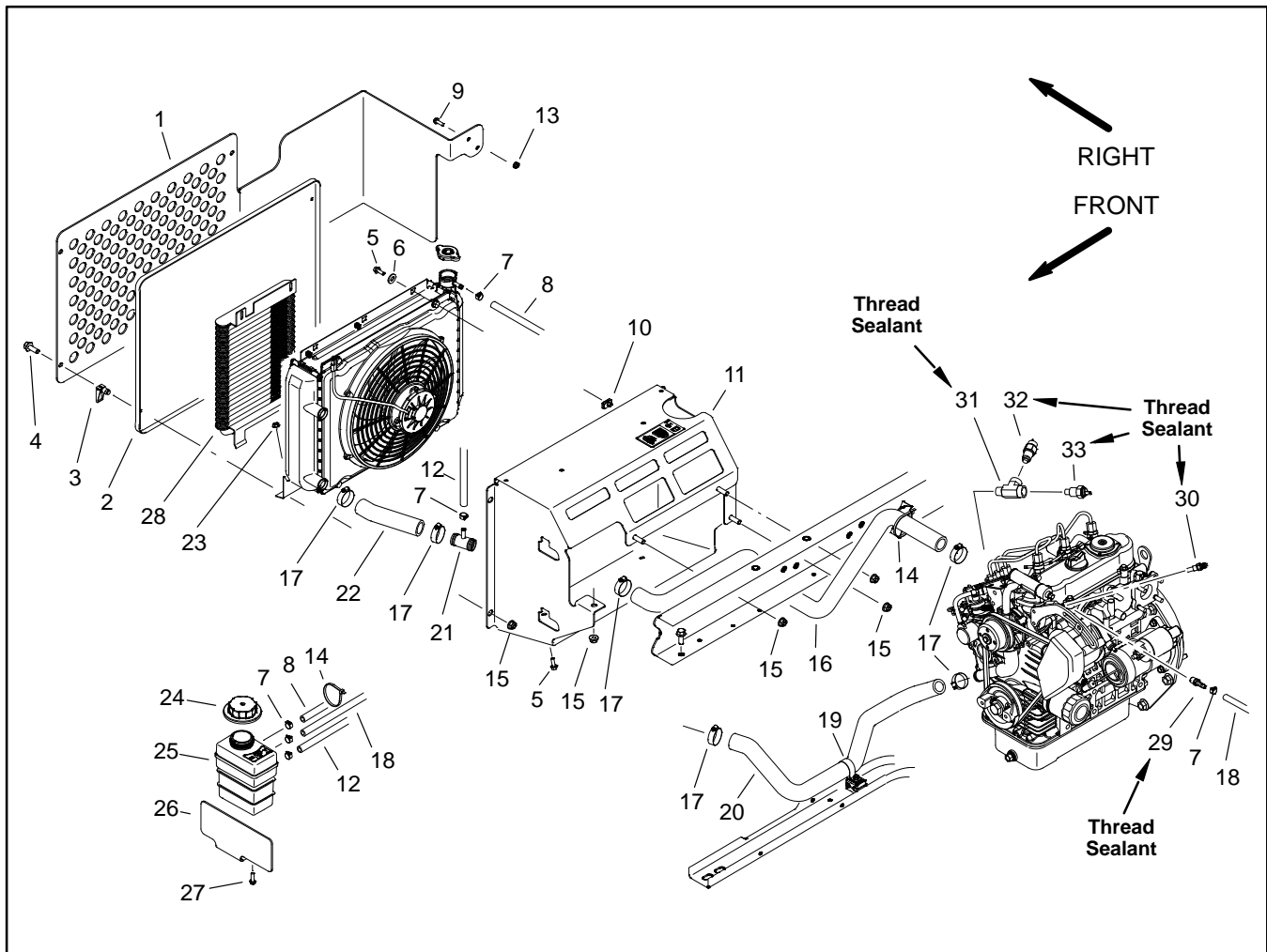
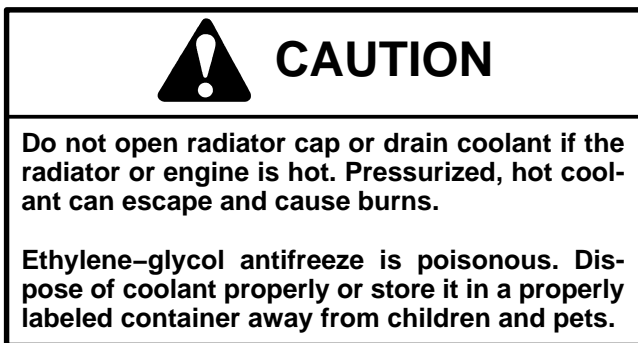

Figure 9

- |                                       |                                    |   |
|---------------------------------------|------------------------------------|---|
| 1. Radiator guard (industrial)        | 11. Radiator mount                 | 23. Flange nut (2)                          |
| 2. Radiator screen                    | 12. Hose (lower hose to reservoir) | 24. Reservoir cap                           |
| 3. Swell latch (4)                    | 13. Flange nut (4 - industrial)    | 25. Coolant reservoir                       |
| 4. Flange head screw (4 - industrial) | 14. Cable tie                      | 26. Reservoir mount                         |
| 5. Flange head screw (4)              | 15. Flange nut (4)                 | 27. Flange head screw (2)                   |
| 6. Flat Washer                        | 16. Upper radiator hose            | 28. Oil cooler (optional)                   |
| 7. Hose clamp                         | 17. Hose clamp (6)                 | 29. Barb fitting                            |
| 8. Hose (radiator to reservoir)       | 18. Hose (engine to reservoir)     | 30. Coolant temperature sensor              |
| 9. Flange head screw (2 - industrial) | 19. R-clamp (2)                    | 31. Tee fitting (industrial)                |
| 10. Clip (2)                          | 20. Lower radiator hose            | 32. Coolant temperature switch (industrial) |
|                                       | 21. Tee fitting                    | 33. Fan thermal switch                      |
|                                       | 22. Lower radiator hose            |   |

## Removal (Fig. 9)

1. Park vehicle on a level surface, stop engine, engage parking brake and remove key from the ignition switch. Allow engine and radiator to cool.
2. Raise or remove the bed or other attachment(s). If bed is raised, place safety support on lift cylinder.
3. Unlatch and remove radiator screen from front of radiator.
4. If vehicle is equipped with high flow hydraulics kit, rotate oil cooler latches and place oil cooler away from radiator.



5. Remove the radiator cap.
6. Drain radiator into a suitable container by disconnecting lower radiator hose from the radiator.
7. Disconnect upper radiator hose from the radiator.
8. Disconnect reservoir hose from the radiator filler neck.
9. Disconnect wire harness connector from radiator fan.
10. Detach radiator assembly from radiator mount:
  - A. Remove two (2) flange head screws and flat washers that secure the top of the radiator assembly to the mount.
  - B. Remove two (2) flange head screws and flange nuts that secure the bottom of the radiator assembly to the mount.
11. Carefully separate radiator assembly from mount and remove from vehicle.
12. Plug all radiator and hose openings to prevent contamination.
13. If necessary, remove components from radiator (Fig. 10).

## Installation (Fig. 9)

1. If radiator assembly was disassembled, install components to radiator using (Fig. 10) as a guide. Make sure that clearance exists between shroud and fan at all points.
2. Remove plugs from radiator openings and hoses placed during the removal procedure.
3. Position radiator assembly to the radiator mount. Secure radiator assembly to the vehicle with removed flange head screws, flat washers and flange nuts.
4. Connect reservoir hose to the radiator filler neck. Secure hose with hose clamp.
5. Connect upper and lower hoses to the radiator. Secure hoses with hose clamps.
6. Connect wire harness connector to radiator fan.
7. Fill radiator with coolant to the bottom of the filler neck.
8. If vehicle is equipped with high flow hydraulics kit, position oil cooler to radiator and secure in place.
9. Install and latch the radiator screen.
10. Lower or install bed or other attachment(s).

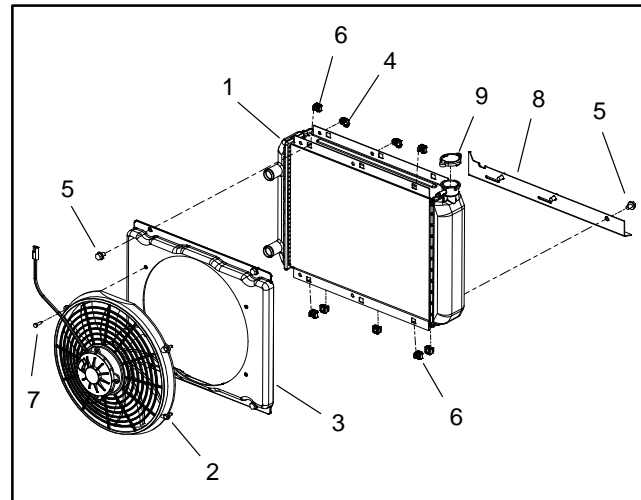

Figure 10

- |                           |                      |
|---------------------------|----------------------|
| 1. Radiator               | 6. Nut (7)           |
| 2. Electric fan           | 7. Screw (4)         |
| 3. Shroud                 | 8. Lower mount plate |
| 4. Latch (2 - oil cooler) | 9. Radiator cap      |
| 5. Flange screw (7)       |                      |

# Engine

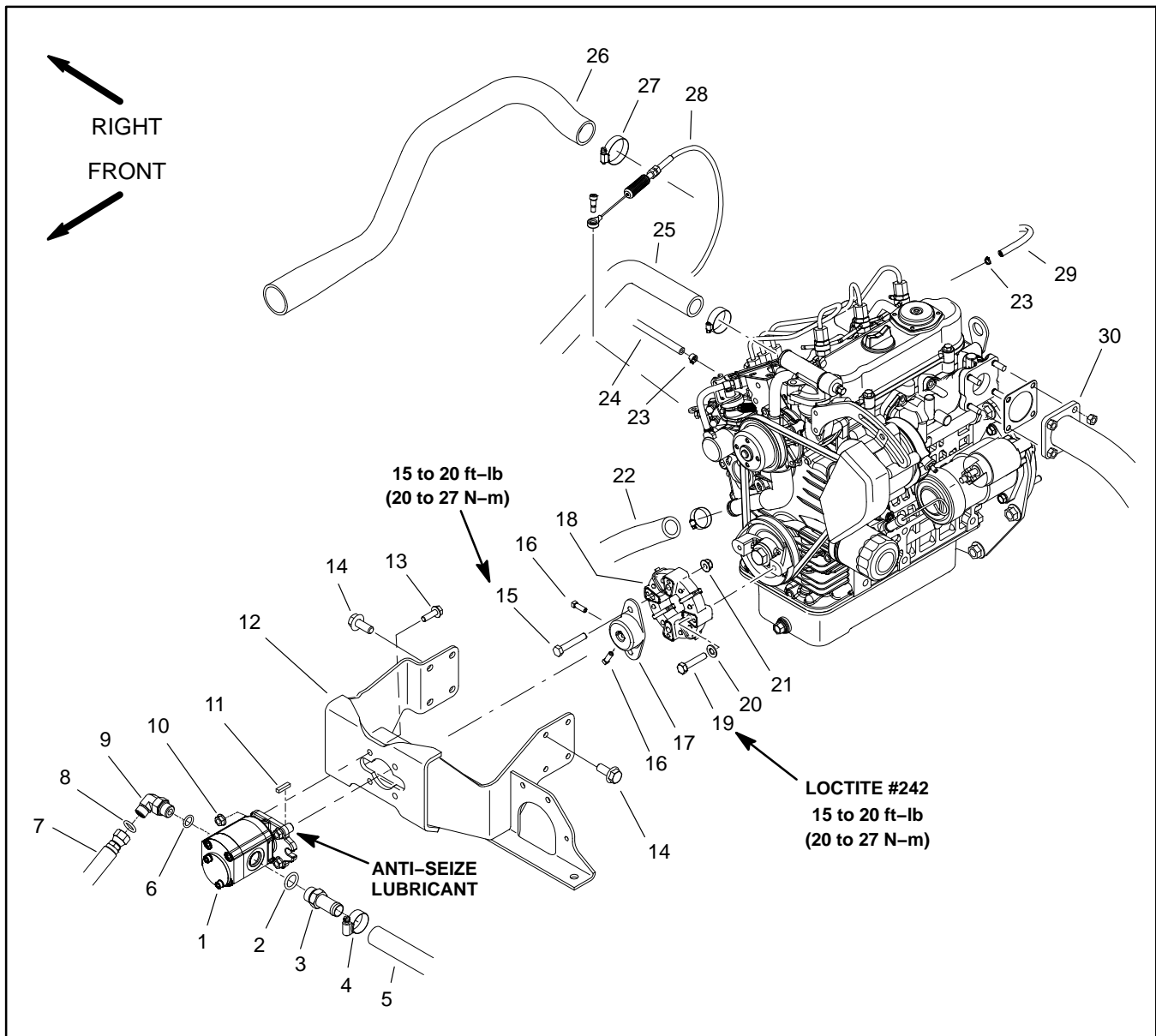

Figure 11

- |                                  |                           |                         |
|----------------------------------|---------------------------|-------------------------|
| 1. Gear pump                     | 11. Square key            | 21. Hex flange nut (2)  |
| 2. O-ring                        | 12. Pump/engine mount     | 22. Lower radiator hose |
| 3. Hydraulic fitting             | 13. Flange head screw (4) | 23. Hose clamp          |
| 4. Hose clamp                    | 14. Flange head screw (8) | 24. Fuel supply hose    |
| 5. Suction hose (from transaxle) | 15. Hex head screw (2)    | 25. Upper radiator hose |
| 6. O-ring                        | 16. Square head screw (2) | 26. Air intake hose     |
| 7. Hose (to lift valve)          | 17. Pump hub              | 27. Hose clamp          |
| 8. O-ring                        | 18. Coupling              | 28. Accelerator cable   |
| 9. Hydraulic fitting             | 19. Hex head screw (2)    | 29. Return fuel hose    |
| 10. Flange nut (4)               | 20. Flat washer (2)       | 30. Exhaust tube        |



## Engine Removal (Fig. 11)

1. Park vehicle on a level surface and engage parking brake. Stop the engine and remove key from ignition switch. Allow engine to cool.

2. Raise or remove the bed or other attachment(s) to gain access to engine. If bed is raised, place safety support on lift cylinder.

3. Disconnect negative (-) and then positive (+) battery cables at the battery.

4. Remove exhaust tube from vehicle (see Exhaust System Removal in this section).

5. Loosen hose clamp that secures air intake hose to engine. Remove intake hose from engine.

6. Disconnect fuel supply and return hoses from fuel injection pump on engine. Plug end of fuel hoses to prevent contamination and fuel spillage. Position disconnected fuel hoses away from engine.

7. Note location of cable ties used to secure wire harness leads. Label and disconnect wire harness connectors that attach to engine:

A. Positive (+) battery cable, fusible link harness and harness ring terminal from starter solenoid stud (Fig. 12).

B. Wire from spade terminal on starter solenoid.

C. Wire from oil pressure switch.

D. Wires from temperature sender and thermal fan switch on water pump housing.

E. Harness connector and wire with ring terminal from alternator.

F. Negative (-) battery cable and harness ground connector secured to engine mount (Fig. 12). Note location of ground connections and flange head screw for assembly purposes.

G. Harness connector with ring terminal from glow plug connector.

H. Harness connector from fuel solenoid on injection pump.

I. Harness connector from crankshaft sensor.

8. Disconnect accelerator cable from throttle lever and cable support bracket. Position accelerator cable away from engine.

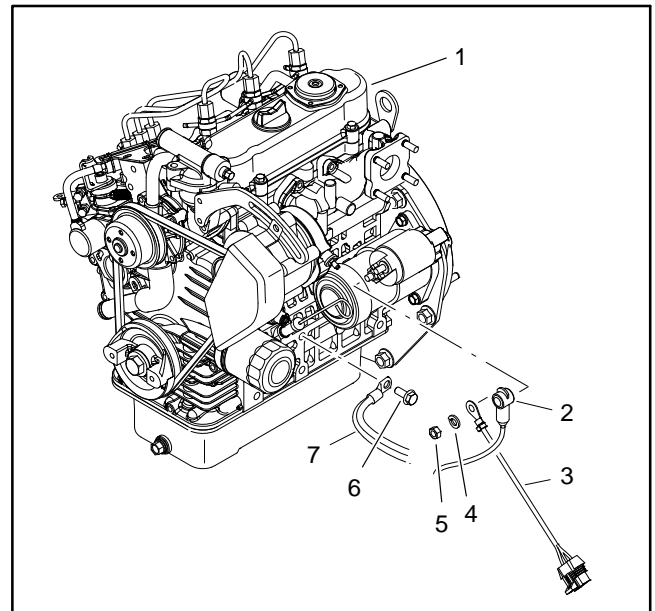

Figure 12

- |                         |                          |
|-------------------------|--------------------------|
| 1. Engine               | 5. Hex nut               |
| 2. Positive cable       | 6. Flange head screw     |
| 3. Fusible link harness | 7. Negative/ground cable |
| 4. Lock washer          |                          |

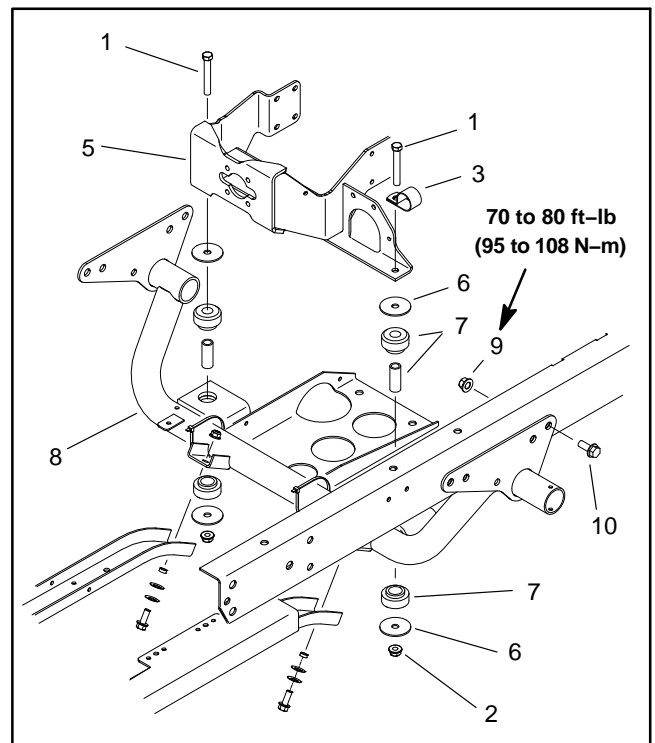

Figure 13

- |                   |                           |
|-------------------|---------------------------|
| 1. Cap screw      | 6. Snubbing washer        |
| 2. Flange nut     | 7. Engine mount assembly  |
| 3. R-clamp        | 8. Engine support         |
| 4. Engine support | 9. Flange nut (8)         |
| 5. Engine mount   | 10. Flange head screw (8) |



## CAUTION

**Do not open radiator cap or drain coolant if the radiator or engine is hot. Pressurized, hot coolant can escape and cause burns.**

**Ethylene-glycol antifreeze is poisonous. Dispose of coolant properly or store it in a properly labeled container away from children and pets.**

9. Remove the radiator cap. Drain radiator into a suitable container by disconnecting lower radiator hose from the radiator.

10. Loosen hose clamps and remove upper and lower radiator hoses from engine. Remove R-clamp that secures lower radiator hose to engine mount. Position radiator hoses away from engine.

11. Remove all clamps and cable ties used to attach wiring harness, hoses or cables to the engine.

12. On 4WD vehicles, remove differential drive shaft (see Differential Driveshaft in Chapter 10 – Front Wheel Drive (4WD)).



## CAUTION

**Before performing any service or repair on hydraulic system components, relieve system pressure to avoid injury from pressurized hydraulic oil. Rotate the steering wheel in both directions, make sure that the bed is lowered onto the bed support and operate any other hydraulic accessories.**

13. Thoroughly clean junction of gear pump fittings and hydraulic hoses. Label hydraulic hoses for assembly purposes. Disconnect hydraulic hoses from gear pump. Install caps or plugs in hoses and pump fittings to prevent contamination and leakage of hydraulic oil.

14. Put blocking under transaxle to prevent the transaxle from moving during engine removal.

15. Loosen and remove two (2) flange nuts, snubbing washers and cap screws that secure engine mounts to engine support (Fig. 13).

16. Remove six (6) cap screws that secure clutch bell housing to engine. Note location of harness bracket(s) (Fig. 14).

17. Use engine lifting lugs provided and a hoist or lift to remove engine from chassis. One person should operate hoist or lift and a second person should help guide engine out of chassis. Move engine forward before lifting to disengage transaxle input shaft from clutch.

18. Note location and retrieve two (2) dowel pins from bell housing (Fig. 14).

19. If necessary, remove gear pump from engine mount (see Gear Pump Removal in Chapter 9 – Hydraulic System).

20. If necessary, remove engine mount from engine.

21. If necessary, remove coupler components from engine pulley.

22. If necessary, remove pressure plate and clutch disc (see Clutch Disassembly and Inspection in Chapter 6 – Drive Train).

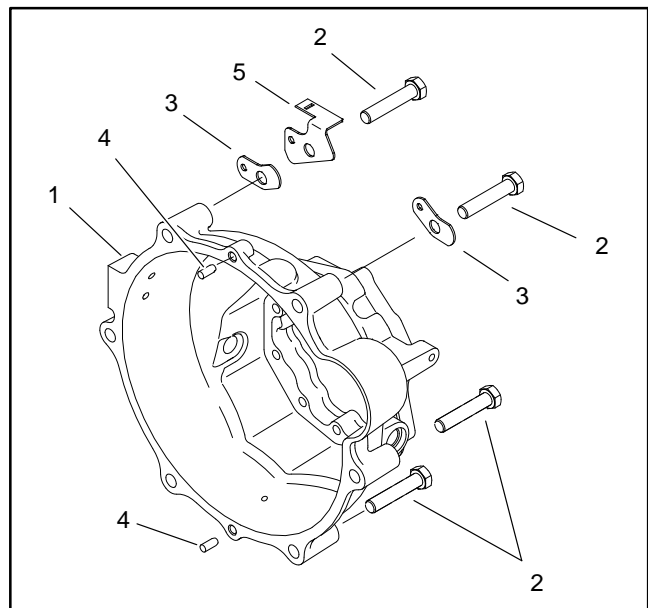

Figure 14

- |                    |                    |
|--------------------|--------------------|
| 1. Bell housing    | 4. Dowel pins (2)  |
| 2. Cap screw (6)   | 5. Harness bracket |
| 3. Harness bracket |                    |

### Engine Installation (Fig. 11)

1. Install pressure plate and clutch disc if removed (see Installing Clutch Disc and Cover in Chapter 6 – Drive Train).

2. If coupler assembly was removed, assemble coupler to engine pulley. Apply Loctite #242 (or equivalent) to threads of flange head screws that secure coupler to engine pulley. Torque fasteners to **15 to 20 ft-lb (20 to 27 N-m)**.
3. If engine mount was removed, secure mount to engine with seven (7) flange head screws. Do not install the screw used to secure the ground connections to the engine at this time.
4. If gear pump was removed, install gear pump to engine mount (see Gear Pump Installation in Chapter 9 – Hydraulic System in this manual).
5. Install two (2) dowel pins in bell housing bores (Fig. 14).
6. Make sure that snubbing washer is positioned on top of both engine mounts (Fig. 13).
7. Apply anti-seize lubricant to splines on transaxle input shaft.
8. Use engine lifting lugs provided and a hoist or lift to install engine to chassis. One person should operate hoist and second person should help guide engine to machine. Align splines on transaxle input shaft and clutch while moving engine to bell housing on transaxle.
9. Secure bell housing to engine with six (6) cap screws and harness bracket(s) (Fig. 14).
10. Secure engine mount to engine support with two (2) cap screws, snubbing washers and flange nuts (Fig. 13).
11. Remove plugs from hydraulic hoses and gear pump fittings. Connect hydraulic hoses to gear pump (see Hydraulic Hose and Tube Installation in Chapter 9 – Hydraulic System).
12. On 4WD vehicles, install differential drive shaft (see Differential Driveshaft Installation in Chapter 10 – Front Wheel Drive (4WD)).
13. Install upper and lower radiator hoses to engine and secure with hose clamps. Install R-clamp to secure lower radiator hose to engine mount.
14. Fill radiator with coolant (see vehicle Operator's Manual).
15. Connect wire harness connectors to engine components. Secure wire harness to machine with cable ties in locations noted during engine removal.
  - A. Positive (+) battery cable, fusible link harness and harness ring terminal from starter solenoid stud (Fig. 12).
  - B. Wire from spade terminal on starter solenoid.
  - C. Wire from oil pressure switch.
  - D. Wires from temperature sender and thermal fan switch on water pump housing.
  - E. Harness connector and wire with ring terminal from alternator.
  - F. Negative (-) battery cable and harness ground connector secured to engine mount (Fig. 12). Note location of ground connections and flange head screw for assembly purposes.
  - G. Harness connector with ring terminal from glow plug connector.
  - H. Harness connector from fuel solenoid on injection pump.
  - I. Harness connector from crankshaft sensor.
16. Secure accelerator cable to throttle lever on engine and cable support bracket.
17. Install air intake hose to engine and secure with hose clamp.
18. Connect fuel supply and return hoses to fuel injection pump on engine. Secure hoses with hose clamps.
19. Install exhaust tube to vehicle (see Exhaust System Installation in this section).
20. Connect positive (+) and then negative (-) battery cables to the battery.
21. Check operation and adjustment of accelerator pedal (see Adjust Accelerator Cable in this chapter).

This page is intentionally left blank.



# Kohler Air Cooled Gasoline Engine

## Table of Contents

SPECIFICATIONS .....	2
GENERAL INFORMATION .....	3
Operator's Manual .....	3
SERVICE AND REPAIRS .....	5
Cooling System .....	5
Exhaust System .....	6
Fuel System .....	8
Fuel Tank .....	9
Fuel Sender .....	9
Carbon Canister .....	10
Engine .....	12
Flywheel and Pilot Bearing Inspection .....	14
KOHLER COMMAND ENGINE SERVICE MANUAL	

# Specifications

Item	Description
Make / Designation	Kohler, CH680-3025, 4-stroke, V-Twin Air Cooled, OHV
Number of Cylinders	2
Bore x Stroke	3.15 in x 2.64 in (80 mm x 67 mm)
Total Displacement	41.1 in <sup>3</sup> (674 cc)
Compression Ratio	8.5:1
Governor	Mechanical
Idle Speed (no load)	1200 ± 100 RPM
High Idle (no load)	3600 ± 50 RPM
Oil Pump	Gear driven trochoid type
Engine Oil	See Operator's Manual
Crankcase Oil Capacity	2 U.S. quarts (1.9 liters) with filter
Fuel	Unleaded, Regular Gasoline (Minimum 87 Octane)
Fuel Pump	Diaphragm (engine mounted)
Fuel Tank Capacity	6.5 U.S. gallons (24.6 liters)
Starter	12 VDC
Alternator/Regulator	12 VDC 25 Amp
Dry Weight (approximate)	90 pounds (41 kilograms)

# General Information

This Chapter gives information about specifications and repair of the Kohler engine used in the Workman HD.

General engine maintenance procedures are described in your Operator's Manual. Information on engine troubleshooting, testing, disassembly and assembly is identified in the Kohler Command Engine Service Manual that is included at the end of this section.

Most repairs and adjustments require tools which are commonly available in many service shops. Special tools are described in the Kohler Command Engine Service Manual. The use of some specialized test equipment is explained. However, the cost of the test equipment and the specialized nature of some repairs may dictate that the work be done at an engine repair facility.

Service and repair parts for Kohler engines are supplied through your local Kohler dealer or distributor.

---

## Operator's Manual

The Operator's Manual provides information regarding the operation, general maintenance and maintenance intervals for your Workman HD vehicle. Refer to the Operator's Manual for additional information when servicing the vehicle.

This page is intentionally blank.



# Service and Repairs

## Cooling System

To ensure proper engine cooling, make sure the grass screen, cooling fins and other external surfaces of the engine are kept clean at all times.

**NOTE:** Perform this maintenance procedure at the interval specified in the Operator's Manual.

**IMPORTANT:** The engine that powers the Workman HD vehicle is air-cooled. Operating the engine with dirty or plugged cooling fins, a blocked grass screen or a plugged or dirty blower housing will result in engine overheating and engine damage.

1. Park vehicle on a level surface, stop engine, engage parking brake and remove key from the ignition switch.
2. Raise or remove the bed or other attachment(s). If bed is raised, place safety support on lift cylinder.

**CAUTION**

The engine may be hot. Allow engine to cool before cleaning the engine cooling fins.

**IMPORTANT:** Never clean engine with pressurized water. Water could enter and contaminate the fuel system.

3. Clean cooling fins on both cylinder heads.
4. Clean grass screen and blower housing of dirt and debris (Fig. 1).
5. If necessary remove blower housing from engine for more thorough engine cleaning.

**IMPORTANT:** Never operate engine without the blower housing installed. Overheating and engine damage will result.

6. Make sure blower housing and/or engine cylinder shrouds are installed to the engine if removed.

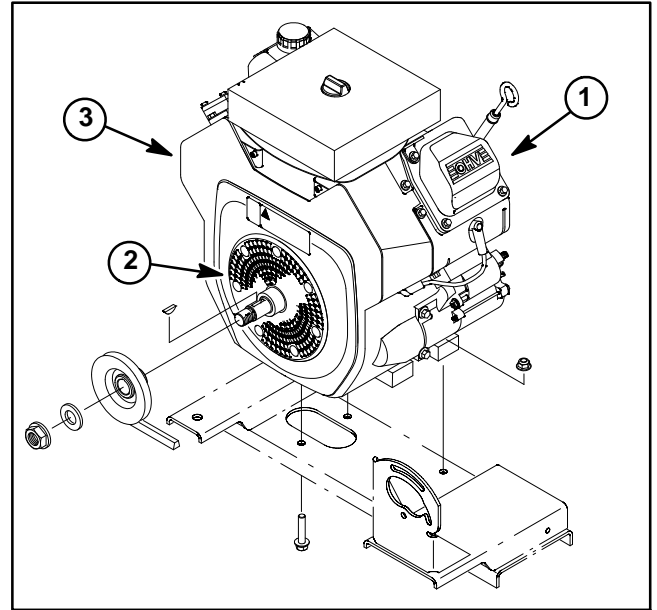

Figure 1

- |                  |                   |
|------------------|-------------------|
| 1. Cylinder head | 3. Blower housing |
| 2. Grass screen  |                   |

# Exhaust System

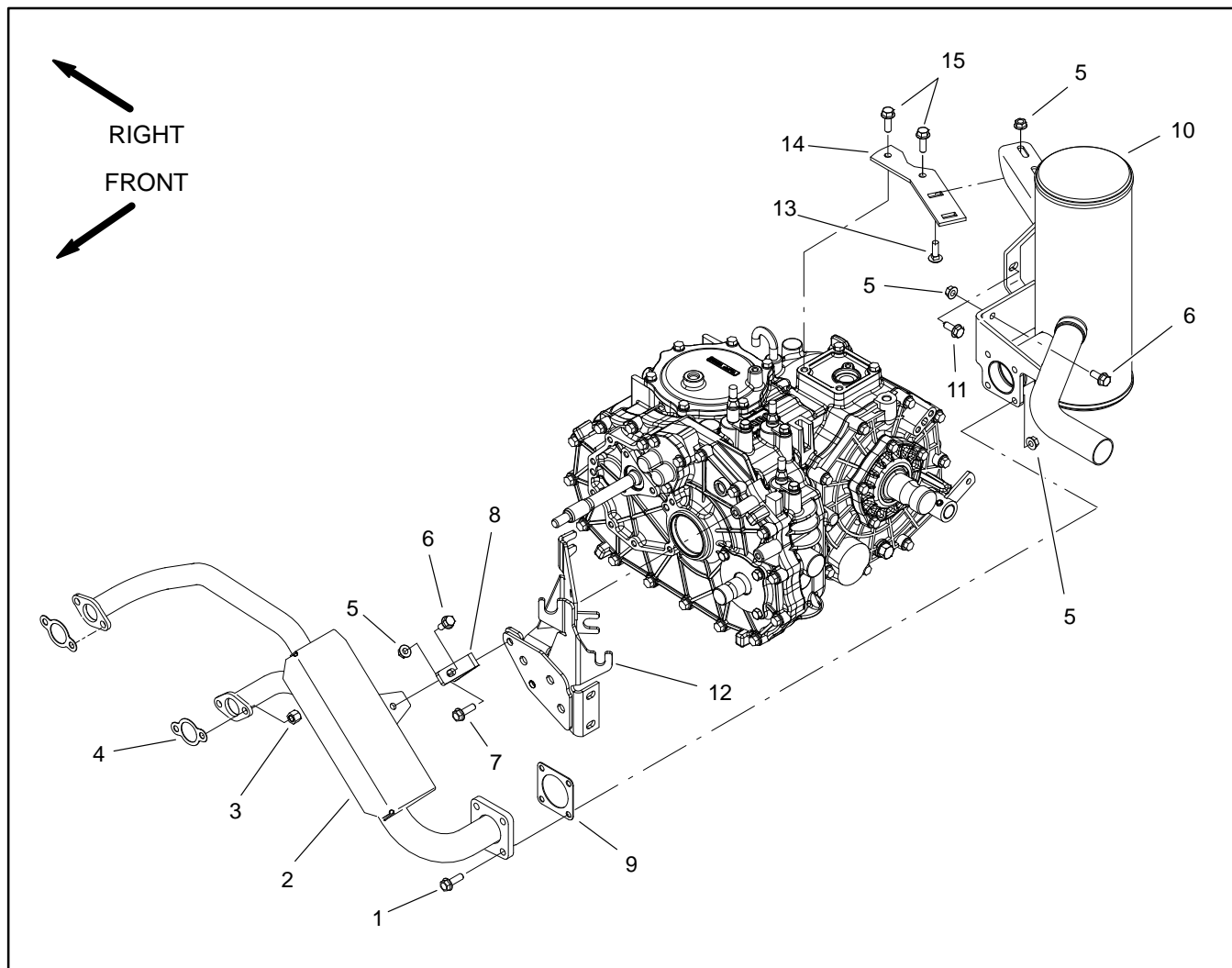

Figure 2

- 1. Flange head screw (4)
- 2. Exhaust manifold
- 3. Hex nut (4)
- 4. Exhaust gasket (2)
- 5. Flange nut (9)

- 6. Flange head screw (3)
- 7. Flange head screw
- 8. Bracket
- 9. Muffler gasket

- 11. Flange head screw
- 12. Shift cable mount bracket
- 13. Carriage bolt (2)
- 14. Muffler mount plate
- 15. Flange head screw (2)

### Removal (Fig. 2)

1. Park vehicle on a level surface and engage parking brake. Stop the engine and remove key from ignition switch. Allow engine to cool.
2. Raise or remove the bed or other attachment(s). If bed is raised, place safety support on lift cylinder.
3. Remove exhaust system components (Fig. 2).
4. Discard gaskets and thoroughly clean flange surfaces of manifold and muffler.

### Installation (Fig. 2)

1. Replace any removed gaskets.
2. Fit all exhaust components to vehicle before tightening any fasteners (Fig. 2). When securing exhaust, tighten fasteners in the following order:
  - A. Hex nuts that secure manifold to engine.
  - B. Flange head screw that secures muffler to trans-axle.
  - C. Flange head screws and flange nuts that secure muffler to manifold.
  - D. Flange head screws and flange nuts that secure muffler to shift cable mount bracket.
  - E. Carriage bolts and flange nuts that secure muffler to mount plate.
  - F. Flange head screw and flange nut that secures exhaust manifold to bracket.
3. Lower or install bed or attachment(s).

## Fuel System

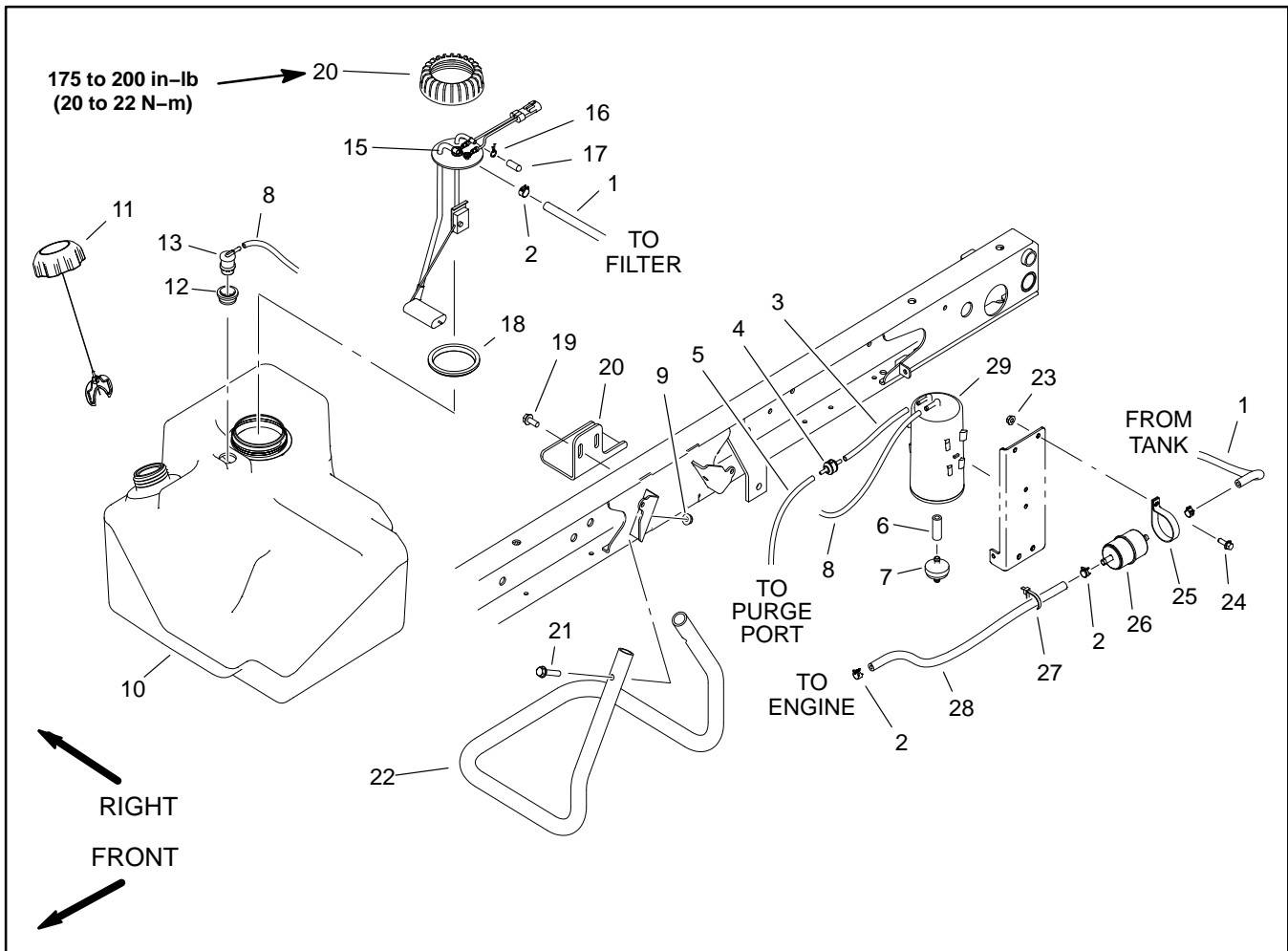

Figure 3

- |                             |                           |                           |
|-----------------------------|---------------------------|---------------------------|
| 1. Fuel hose (to filter)    | 11. Fuel tank cap         | 21. Washer head screw (2) |
| 2. Hose clamp               | 12. Grommet               | 22. Support tube          |
| 3. Fuel hose                | 13. Rollover valve        | 23. Flange nut            |
| 4. Vacuum check valve       | 14. Fuel sender cap       | 24. Flange head screw (2) |
| 5. Fuel hose (engine purge) | 15. Fuel sender           | 25. R-clamp               |
| 6. Filter hose              | 16. Hose clamp            | 26. Fuel filter           |
| 7. Canister filter          | 17. Cap                   | 27. Cable tie             |
| 8. Fuel hose (tank vent)    | 18. Gasket                | 28. Fuel hose (to engine) |
| 9. Flange nut (2)           | 19. Washer head screw (2) | 29. Carbon canister       |
| 10. Fuel tank               | 20. Retainer plate        |                           |



### DANGER

Because gasoline is highly flammable, use caution when storing or handling it. Do not smoke while filling the fuel tank. Do not fill fuel tank while engine is running, hot or when vehicle is in an enclosed area. Always fill fuel tank outside and wipe up any spilled fuel before starting the engine. Store fuel in a clean, safety-approved container and keep cap in place. Use fuel for the engine only; not for any other purpose.

### Check Fuel Lines and Connections

Check fuel lines and connections periodically as recommended in the Operator's Manual. Check lines for deterioration, damage, leaks or loose connections. Replace hoses, clamps and connections as necessary.

### Fuel Tank Removal (Fig. 3)

1. Park vehicle on a level surface and engage parking brake. Stop the engine and remove key from ignition switch. Allow engine to cool.
2. Raise or remove the bed or other attachment(s). If bed is raised, place safety support on lift cylinder.
3. Disconnect wire harness connector from fuel sender on fuel tank.
4. Note routing of fuel hoses for installation purposes (Fig. 4). Disconnect fuel hoses from fuel sender and rollover valve. Plug fuel hoses to prevent leakage or contaminant entry.
5. Remove washer head screws and retainer plate that secure fuel tank.
6. Remove fuel tank from vehicle.

### Fuel Tank Installation (Fig. 3)

1. Position fuel tank to support tube.
2. Remove plugs placed in fuel hoses during fuel tank removal. Connect fuel hoses to fuel sender and rollover valve (Fig. 4). Secure fuel hoses with hose clamps.
3. Connect wire harness connector to fuel sender.
4. Position retainer plate to tank and frame. Make sure that fuel hoses are correctly placed under retainer. While pressing down on retainer plate to best retain tank, install and tighten washer head screws (item 19) to secure fuel tank.
5. Lower or install the bed or other attachment(s).
6. Fill fuel tank. Check for fuel leakage and correct if found.

### Fuel Sender Removal (Fig. 3)

1. Park vehicle on a level surface, raise bed and engage parking brake. Stop the engine and remove key from ignition switch. Allow engine to cool.
2. Install bed support on bed lift cylinder to prevent bed from lowering.
3. Disconnect vehicle wire harness connectors from fuel sender assembly on fuel tank.
4. Disconnect fuel hoses from fuel sender. Plug fuel hoses to prevent leakage or system contamination.
5. Note orientation of fuel fittings on fuel sender for assembly purposes.

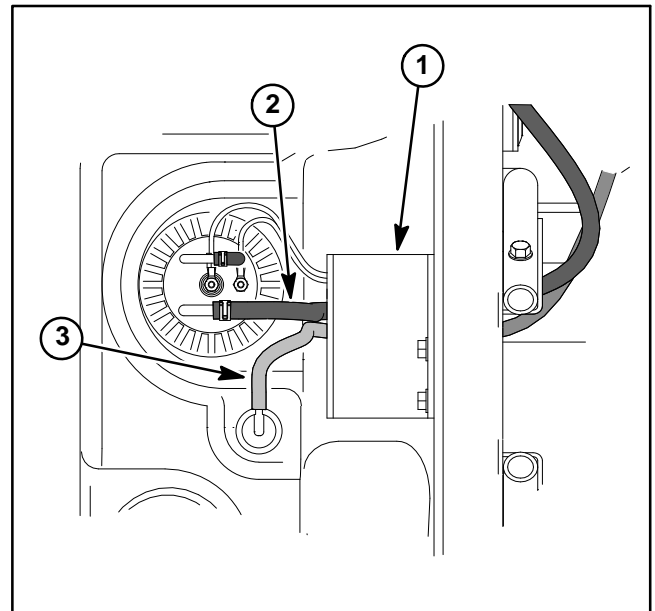

Figure 4

- |                     |                   |
|---------------------|-------------------|
| 1. Retainer plate   | 3. Tank vent hose |
| 2. Fuel supply hose |                   |

6. Remove cap that secures fuel sender assembly in fuel tank.

**NOTE:** Do not allow fuel sender assembly to rotate during removal or damage to the sender float arm may result.

7. Carefully remove fuel sender and gasket from tank.

### Fuel Sender Installation (Fig. 3)

1. Make sure that fuel tank and fuel sender gasket surfaces are thoroughly clean.
2. Position gasket to sealing surface of fuel sender.
3. Carefully insert fuel sender and gasket into tank. Orientate fuel fittings so that it is pointing toward the vehicle frame.
4. Secure fuel sender to fuel tank with cap. Torque cap from **175 to 200 in-lb (20 to 22 N-m)**.
5. Remove plugs placed in fuel hoses and connect hoses to fuel sender. Secure fuel hoses with hose clamps.
6. Connect vehicle wire harness connectors to fuel sender assembly on fuel tank.
7. Remove bed support from lift cylinder and lower bed.

## Carbon Canister

The function of the fuel evaporative control system is to collect and store evaporative emissions from the fuel tank and engine. A carbon canister that is mounted to the left side of the frame is used to collect these evaporative emissions. Fuel vapors from the engine and fuel tank are vented to the canister when the engine is not running. Vapors from the canister are consumed when the engine is running.

**NOTE:** If there is restriction in the canister breather, the carbon canister or the vacuum check valve, the fuel tank may distort due to venting issues. If the fuel tank returns to its normal shape when the fuel cap is removed, restriction in the evaporative control system is likely.

## Carbon Canister Removal

1. Park vehicle on a level surface, raise bed and engage parking brake. Stop the engine and remove key from ignition switch. Allow engine to cool.



**DANGER**

**Gasoline is flammable. Use caution when storing or handling it. Do not smoke while filling the fuel tank. Do not fill fuel tank while engine is running or in an enclosed area. Always fill fuel tank outside and wipe up any spilled fuel before starting the engine. Store fuel in a clean, safety-approved container and keep the cap in place. Use gasoline for the engine only; not for any other purpose.**

2. Inspect carbon cannister and attached hoses for damage or obvious leaks. A damaged or leaking cannister should be replaced.

3. Note hose routing, cable tie and anchor clamp locations. Remove fuel evaporative control system components as needed (Fig. 5).

## Carbon Canister Installation

1. Install all removed EVAP components. Make sure that fuel hoses are not kinked after installation. Secure all hoses with hose clamps, anchor clamps and cable ties as noted. If hoses were removed from the carbon canister, check hose connections for correct system operation (Fig. 5).

2. After all evaporative control system components are installed, remove bed support from lift cylinder and lower bed.

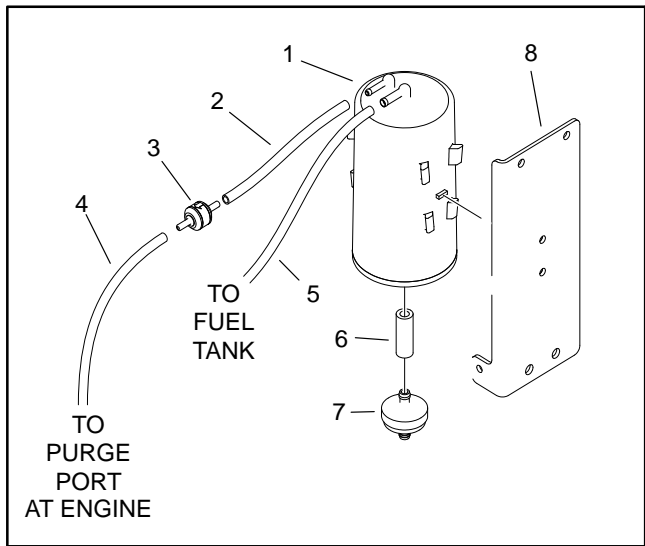

Figure 5

- |                          |                        |
|--------------------------|------------------------|
| 1. Carbon canister       | 5. Fuel hose (to tank) |
| 2. Fuel hose             | 6. Filter hose         |
| 3. Vacuum check valve    | 7. Canister filter     |
| 4. Fuel hose (to engine) | 8. Canister mount      |

This page is intentionally blank.

# Engine

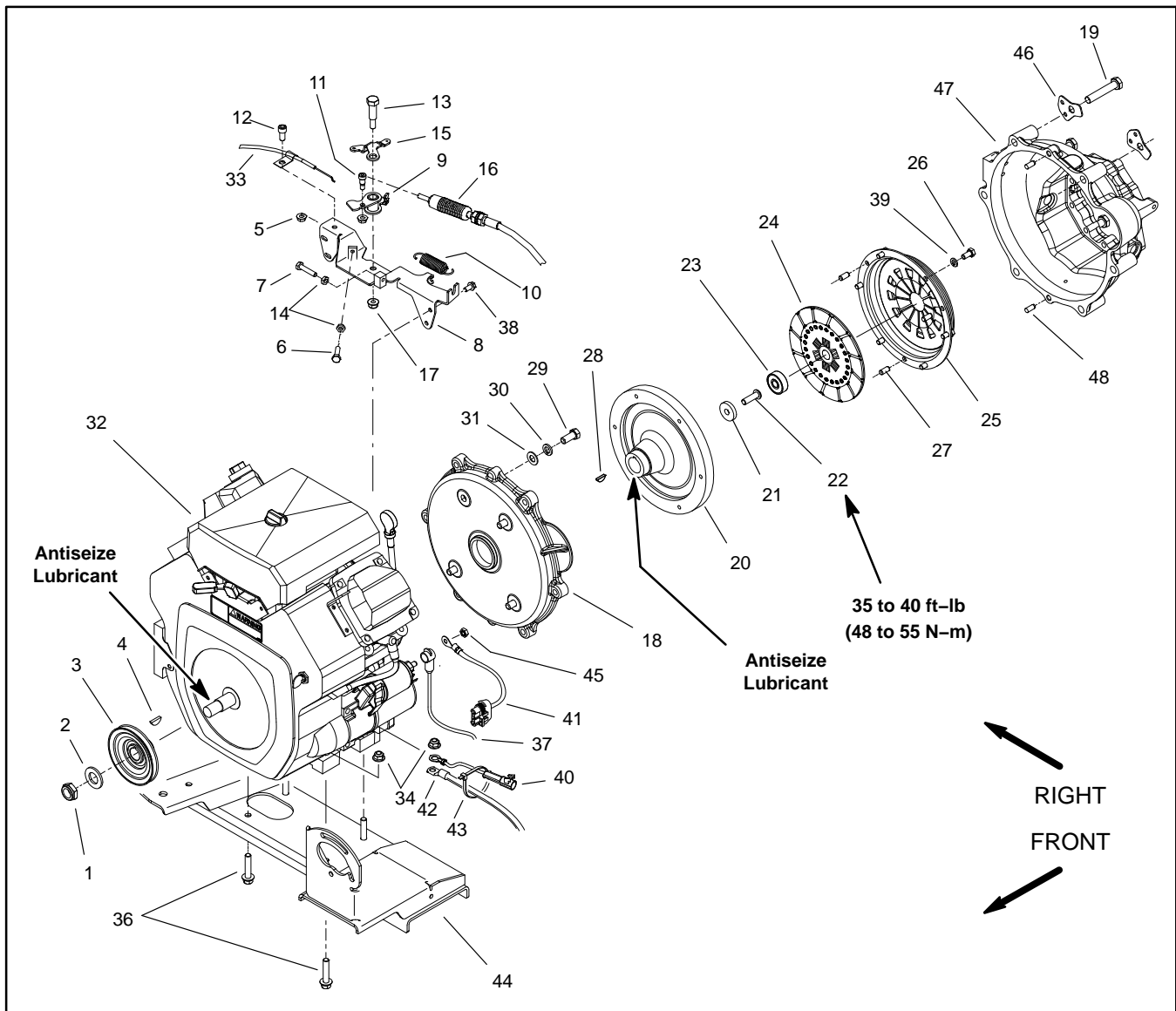

Figure 6

- |                               |                       |                              |
|-------------------------------|-----------------------|------------------------------|
| 1. Lock nut                   | 17. Flange nut        | 33. Choke cable              |
| 2. Flat washer                | 18. Clutch adapter    | 34. Flange nut (4)           |
| 3. Pulley                     | 19. Cap screw (6)     | 35. Lock nut                 |
| 4. Woodruff key               | 20. Flywheel          | 36. Flange head screw (4)    |
| 5. Flange nut                 | 21. Washer            | 37. Positive battery cable   |
| 6. Cap screw (low idle stop)  | 22. Socket head screw | 38. Washer head screw (4)    |
| 7. Cap screw (high idle stop) | 23. Pilot bearing     | 39. Lock washer (6)          |
| 8. Throttle bracket           | 24. Clutch disc       | 40. Ground wire harness      |
| 9. Throttle lever             | 25. Pressure plate    | 41. Fusible link harness     |
| 10. Return spring             | 26. Cap screw (6)     | 42. Negative battery cable   |
| 11. Shoulder bolt             | 27. Pin (3)           | 43. Cable tie                |
| 12. Socket head screw         | 28. Woodruff key      | 44. Engine mount             |
| 13. Shoulder screw            | 29. Cap screw (4)     | 45. Nut                      |
| 14. Jam nut (2)               | 30. Lock washer (4)   | 46. Wire harness bracket (2) |
| 15. Choke lever               | 31. Flat washer (4)   | 47. Bell housing             |
| 16. Accelerator cable         | 32. Engine assembly   | 48. Dowel pin (2)            |



## Engine Removal (Fig. 6)

1. Park vehicle on a level surface and engage parking brake. Stop the engine and remove key from ignition switch. Allow engine to cool.

2. Raise or remove the bed or other attachment(s). If bed is raised, place safety support on lift cylinder.

3. Disconnect negative (-) and then positive (+) battery cables at the battery.

4. Disconnect positive cable and fusible link harness from starter solenoid stud on engine.

5. Remove the muffler and exhaust manifold (see Exhaust System Removal in this section).

6. Disconnect fuel hose from fuel pump on engine. Plug end of fuel hose to prevent contamination and fuel spillage. Position disconnected fuel hose away from engine.

7. Label and disconnect wire harness connectors that attach to engine and engine accessories.

8. Loosen fasteners that secure hydraulic pump to engine mount (Fig. 7). Rotate pump toward engine to allow drive belt to be removed from pump and engine pulleys.

9. Disconnect accelerator cable shoulder bolt from throttle lever on engine. Loosen jam nuts on cable and remove cable from throttle bracket. Position accelerator cable away from engine (Fig. 8).

10. Disconnect choke cable from choke lever on engine. Remove choke cable from bracket (Fig. 8).

11. Remove all clamps and cable ties that attach wire harness, hoses and cables to the engine.

12. Put blocking under transaxle to prevent it from moving during engine removal.

13. Loosen and remove four (4) flange nuts and flange head screws that secure engine to engine mount.

14. Remove six (6) cap screws and two (2) harness brackets that secure clutch bell housing to clutch adapter on engine.

15. Use lift or hoist to remove engine from chassis. One person should operate hoist and a second person should help guide engine out of chassis. Move engine forward before lifting to disengage transaxle input shaft from clutch.

16. Note location and retrieve two (2) dowel pins from bell housing.

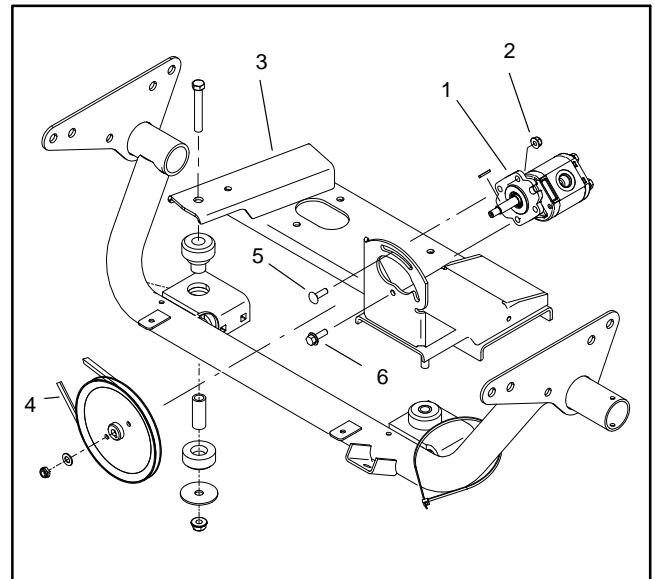

Figure 7

- |                   |                      |
|-------------------|----------------------|
| 1. Hydraulic pump | 4. Pump drive belt   |
| 2. Flange nut (2) | 5. Carriage screw    |
| 3. Engine mount   | 6. Flange head screw |

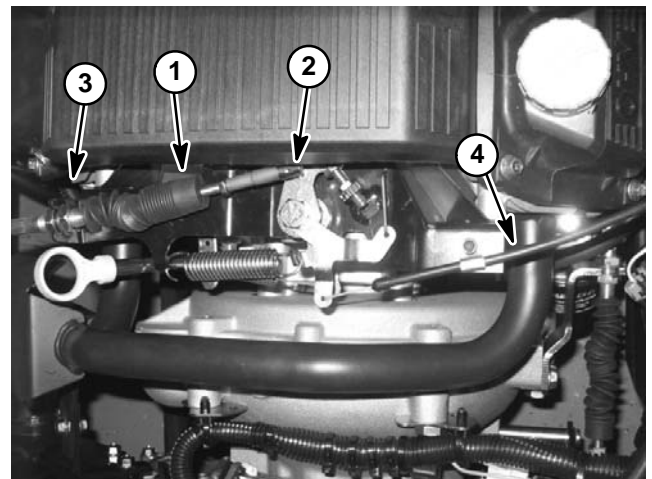

Figure 8

- |                      |                |
|----------------------|----------------|
| 1. Accelerator cable | 3. Jam nuts    |
| 2. Ball joint        | 4. Choke cable |

17. If necessary, remove hydraulic pump drive pulley from stub shaft on flywheel side of engine. Locate and retrieve woodruff key.

18. If pressure plate and clutch disc removal is necessary, see Clutch Service and Repair in Chapter 6 – Drive Train in this manual.

## Flywheel and Pilot Bearing Inspection

1. Inspect flywheel surface for stepped wear, streaking or seizure and replace if necessary. Check flywheel run-out and replace if runout exceeds 0.005 in. (0.13 mm).
2. Check pilot bearing for smooth rolling and noise. Check (sealed) bearing for grease leakage. Replace bearing if necessary. Remove pilot bearing from flywheel by backing out socket head screw that attaches flywheel to crankshaft. Do not reuse bearing if it has been removed.

## Engine Installation (Fig. 6)

1. Install flywheel and/or pilot bearing if removed. Torque socket head screw from **35 to 40 ft-lb (48 to 55 N-m)** to secure flywheel to engine crankshaft.
2. If pressure plate and clutch disc were removed from engine, see Clutch Service in Chapter 6 – Drive Train in this manual.
3. If hydraulic pump drive pulley was removed from engine, apply anti-seize lubricant on engine stub shaft before installing pulley.
4. Place two (2) dowel pins in bell housing.
5. Use lift or hoist to install engine to chassis. One person should operate hoist and a second person should help guide engine to machine. Align splines on transaxle input shaft and clutch while moving engine to bell housing on transaxle.
6. Secure bell housing to clutch adapter on engine with six (6) cap screws and two (2) harness brackets.

7. Secure engine to engine mount with four (4) flange nuts and flange head screws.
8. Connect choke cable to choke lever on engine (Fig. 8).
9. Connect accelerator cable ball joint to throttle lever on engine (Fig. 8). Secure cable to throttle bracket with jam nuts.
10. Connect wire harness connectors to engine components.
11. Connect fuel hose to fuel pump on engine and secure with hose clamp.
12. Secure positive cable and fusible link harness to starter solenoid stud on engine.
13. Install the muffler and exhaust manifold (see Exhaust System Installation in this section).
14. Install a new engine oil filter. Fill engine with the correct oil.
15. Install hydraulic pump drive belt to pump and engine pulleys. Adjust belt tension (see vehicle Operator's Manual).
16. Connect positive (+) and then negative (-) battery cables to the battery.
17. Check operation of accelerator and choke cables.
18. Lower bed or install bed or attachment(s).



Table of Contents

SPECIFICATIONS ..... 2  
GENERAL INFORMATION ..... 3  
    Drive Train Operation ..... 3  
    Operator’s Manual ..... 3  
SPECIAL TOOLS ..... 4  
    Clutch Alignment Tool ..... 4  
ADJUSTMENTS ..... 5  
    Power–Take–Off (PTO) Cable Adjustment  
    (if Equipped) ..... 5  
TROUBLESHOOTING ..... 6  
    Clutch ..... 6  
    Transaxle ..... 8  
SERVICE AND REPAIRS ..... 10  
    Shift Cable Replacement ..... 10  
    Driveshaft ..... 12  
    Driveshaft Cross and Bearing Service ..... 14  
    Power–Take–Off (PTO)  
    Removal and Installation (If Equipped) ..... 15  
    Transaxle ..... 16  
    Transaxle Removal ..... 17  
    Transaxle Installation ..... 18  
    Clutch Service ..... 20  
    Transaxle Service ..... 23  
    Transaxle Disassembly ..... 23  
    Transaxle Inspection ..... 35  
    Transaxle Assembly ..... 39  
    Power Take–Off (PTO) Service (If Equipped) ... 56  
    Disassembly ..... 56  
    Inspection ..... 61  
    Assembly ..... 62

Drive Train

# Specifications

Item	Specification
Transaxle Oil	Dexron III ATF
Transaxle Oil Capacity	7.5 U.S. quart (7.1 liter) system capacity

# General Information

## Drive Train Operation

Workman HD series vehicles are equipped with a Toro designed transaxle with 3 forward speeds, 1 reverse speed and a differential lock. Hi-Lo range gives an effective 6 forward and 2 reverse speeds.

The transaxle is a constant mesh, collar shift transmission with synchronizers for gears 1, 2 and 3. Reverse and High-Low range must be shifted with the vehicle stationary.

An optional top mounted PTO operates at 540 RPM.

The transaxle with automotive type clutch is bolted to the engine with the engine/transaxle assembly isolation mounted to the vehicle frame.

Two (2) heavy duty universal driveshafts transfer power from the transaxle to the rear wheels. A fully independent rear suspension and Dedion type rear axle isolate the mid-mounted engine/transaxle assembly from the terrain.

The transaxle housing also functions as the hydraulic system reservoir.

On units equipped with four wheel drive (4WD), a front output shaft in the transaxle transfers power from the transaxle to the front differential and then to the front wheels. For information on front wheel drive for 4WD vehicles, see Chapter 10 – Front Wheel Drive (4WD).

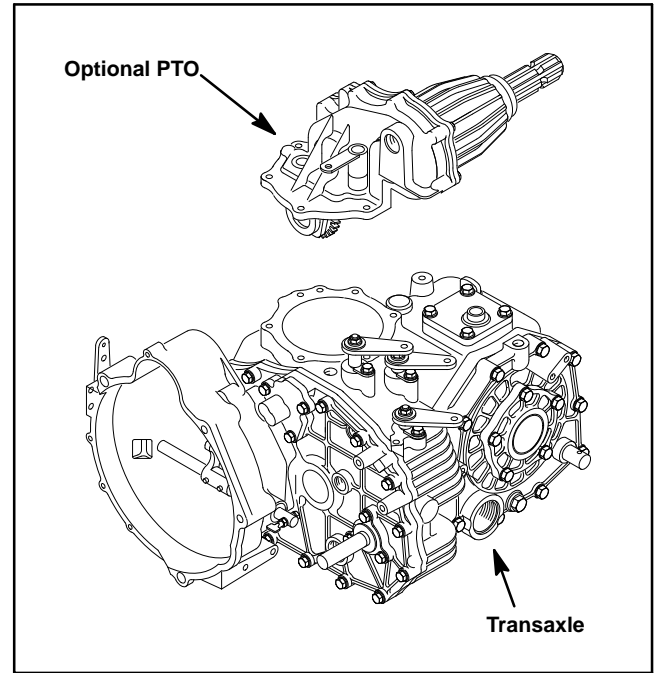

Figure 1

## Operator's Manual

The vehicle Operator's Manual provides information regarding the operation, general maintenance and maintenance intervals for your Workman vehicle. Refer to the Operator's Manual for additional information when servicing the vehicle.

# Special Tools

Order special tools from your Toro Distributor.

---

## Clutch Alignment Tool

Use clutch alignment tool to align clutch friction disk to engine flywheel before tightening pressure plate cap screws.

Toro Part Number: **TOR6002**



Figure 2

# Adjustments

## Power-Take-Off (PTO) Cable Adjustment (If Equipped)

1. Remove clevis pin that secures PTO cable to PTO lever arm.
2. Loosen clevis jam nut and adjust clevis so clevis hole aligns with hole in PTO lever arm.
3. Tighten jam nut making sure that holes in clevis and lever arm still align.
4. Secure PTO cable clevis to PTO lever arm with clevis pin.

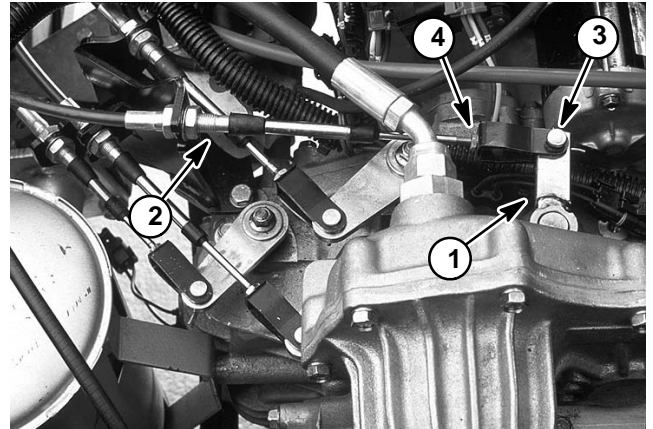

Figure 3

- |                  |                   |
|------------------|-------------------|
| 1. PTO lever arm | 3. Clevis pin     |
| 2. PTO cable     | 4. Clevis jam nut |

# Troubleshooting

## Clutch

Problem	Possible Causes
Clutch slips.	Clutch pedal out of adjustment. Excessive wear of clutch disc facing. Hardening of clutch disc facing, or adhesion of oil. Weak or broken clutch diaphragm spring. Damaged pressure plate or flywheel.
Clutch operation erratic or rough.	Improper installation of clutch cover assembly. Damaged clutch disc. Excessive wear of clutch disc facing. Weak or broken clutch torsion spring. Damaged or broken clutch pressure plate. Bent or broken clutch diaphragm spring tip. Dirty or improperly lubricated clutch disk spline. Damaged or distorted flywheel. Damaged release bearing.
Clutch noisy.	Improper installation of clutch cover assembly. Excessive wear of clutch disc facing. Worn clutch disc spline. Weak or broken clutch torsion spring. Damaged pilot bushing. Damaged release bearing.



---

## Clutch (Continued)

Problem	Possible Causes
Clutch drags or does not release.	Control cable loose or out of adjustment. Bent or broken clutch diaphragm spring tip. Damaged or distorted clutch disc. Worn or rusted clutch disc spline. Damaged pressure plate or flywheel. Damaged release bearing.
Clutch chatters.	Worn or damaged clutch disc facing. Oil adhered to clutch disc facing. Uneven height of diaphragm spring. Weak or damaged clutch torsion spring. Damaged pressure plate or flywheel. Damaged clutch release bearing. Loose or worn front wheel bearings.

## Transaxle

Problem	Possible Causes
Noisy operation.	<p>Low oil level in transaxle.</p> <p>Damaged or worn bearings.</p> <p>Gears worn, scuffed or broken.</p> <p>Excessive end play in countershaft.</p> <p>Gears loose on shaft.</p> <p>Excessive wear of differential side gear liners and pinion liners.</p> <p>Excessive wear of splined slider on axle drive joints.</p>
Difficult shifting.	<p>Clutch not releasing.</p> <p>Shift cable out of adjustment.</p> <p>Shift cable damaged.</p> <p>Shifter cap screw loose (at operator station).</p> <p>Loose shift lever on transaxle.</p> <p>Cable clamp securing cables near shifter is loose.</p> <p>Sliding gear tight on shaft or splines.</p> <p>Synchronizing unit damaged.</p> <p>Sliding gear teeth damaged.</p> <p>Synchronizer keys damaged.</p>
Gears make clashing noise when shifting.	<p>Shifting too fast.</p> <p>Excessive wear of synchro rings.</p> <p>Excessive wear of differential side gear liners and pinion liners.</p> <p>Damaged synchro springs and/or keys.</p> <p>Main gear needle bearings worn or damaged.</p> <p>Excessive wear of driveshaft(s).</p>
Transaxle sticks in gear.	<p>Clutch not releasing.</p> <p>Shift fork detent ball stuck.</p> <p>Shift linkage damaged, loose or out of adjustment.</p> <p>Sliding gears tight on shaft splines.</p> <p>Synchronizer shift keys damaged.</p>

---

## Transaxle (Continued)

Problem	Possible Causes
Transaxle slips out of gear.	Shift linkage out of adjustment. Gear loose on shaft. Gear teeth worn. Excessive end play in gears. Lack of spring pressure on shift fork detent ball. Badly worn bearings.
Overheating of transaxle.	Oil level too high. Excessive hydraulic load. See Chapter 9 – Hydraulic System.

# Service and Repairs

## Shift Cable Replacement

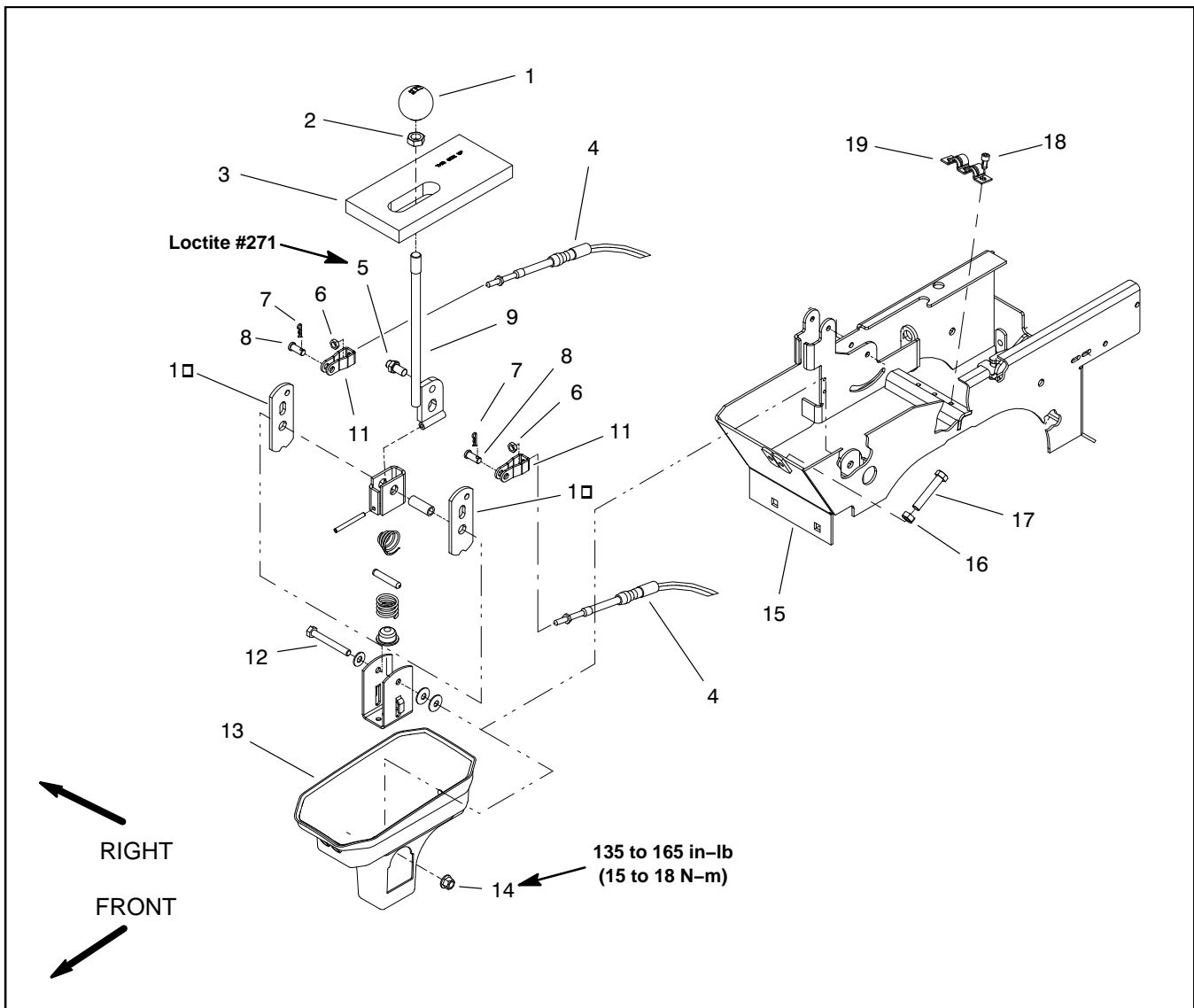

Figure 4

- 1. Shift knob
- 2. Jam nut
- 3. Boot seal
- 4. Shift cable
- 5. Shift pin
- 6. Jam nut
- 7. Hair pin

- 8. Clevis pin
- 9. Shift lever
- 10. Shift link
- 11. Cable clevis
- 12. Cap screw
- 13. Lower shift boot

- 14. Lock nut
- 15. Lever support
- 16. Hex nut (2)
- 17. Shift stop bolt (2)
- 18. Screw (3)
- 19. Cable clamp

### Shift Cable Removal (Fig. 4)

1. Park vehicle on a level surface, raise and support bed (if installed), shut engine off and engage the parking brake. Remove key from the ignition switch.

2. Remove knobs from control levers, then remove center console shift boot and control plate (Fig. 5).

3. Remove three (3) screws and cable clamp that secure shift cables to lever support.

4. Remove hair pin and clevis pin that secure shift cable clevis to shift link on shifter in operator platform.

5. Loosen jam nut that retains clevis to shift cable and remove clevis from cable.

6. Remove shift cable from transaxle shift lever (Fig. 6):
  - A. Remove hair pin and clevis pin that secure shift cable to shift lever on transaxle.
  - B. Loosen jam nuts on bulkhead fitting of cable.
  - C. Disconnect cable from shift lever.
7. Note routing of shift cable and location of cable ties used to secure cable to vehicle. Slide shift cable from lower shift boot and remove cable from vehicle.

#### Shift Cable Installation (Fig. 4)

1. Route shift cable in same location as noted during cable removal.
2. Install cable clevis onto front of shift cable so clevis is at mid-point of threaded end of cable. Tighten jam nut to secure clevis to cable.
3. Connect shift cable to shift link on shifter in operator platform by inserting clevis pin from the passenger side, then install hair pin.
4. Secure shift cables to lever support with cable clamp and three (3) screws.
5. Spread jam nuts on bulkhead fitting of cable (Fig. 6). With cable properly routed to transaxle, install cable bulkhead fitting to shift cable mount bracket on transaxle and tighten jam nuts.
6. Install cable ties in the original locations to secure shift cables to vehicle.
7. Adjust shift cables (see vehicle Operator's Manual) and secure cable clevis to transaxle shift lever with clevis pin and hair pin.
8. Check adjustment of shift stop bolts. Move shift lever forward until lever stops. Hold lever in stopped position and adjust stop bolt so that head just contacts lever. Tighten hex nut on stop bolt.
9. Install shift boot, control plate and control lever knobs.

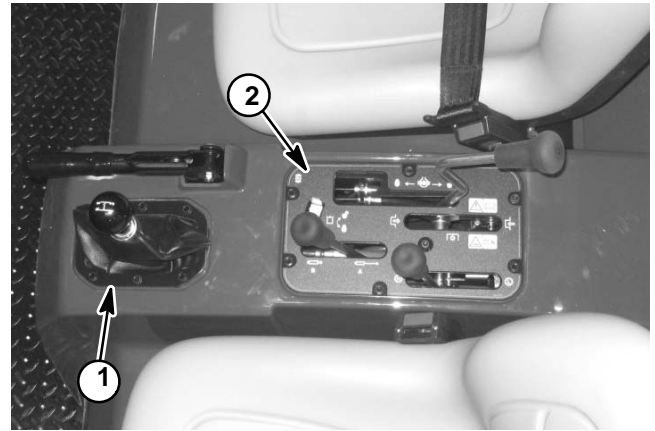

Figure 5

1. Shift boot
2. Control plate

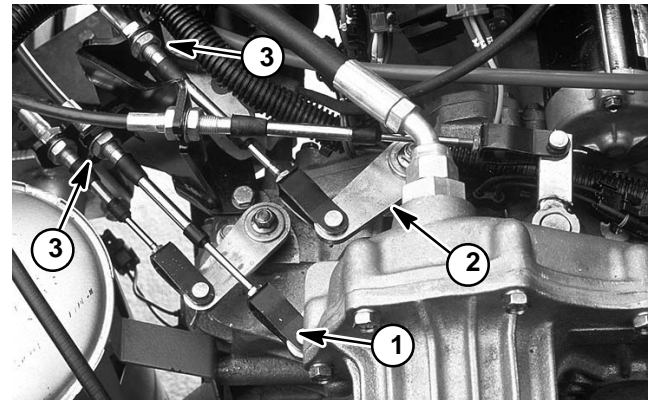

Figure 6

1. First-Reverse
2. 2nd-3rd
3. Bulkhead jam nut

# Driveshaft

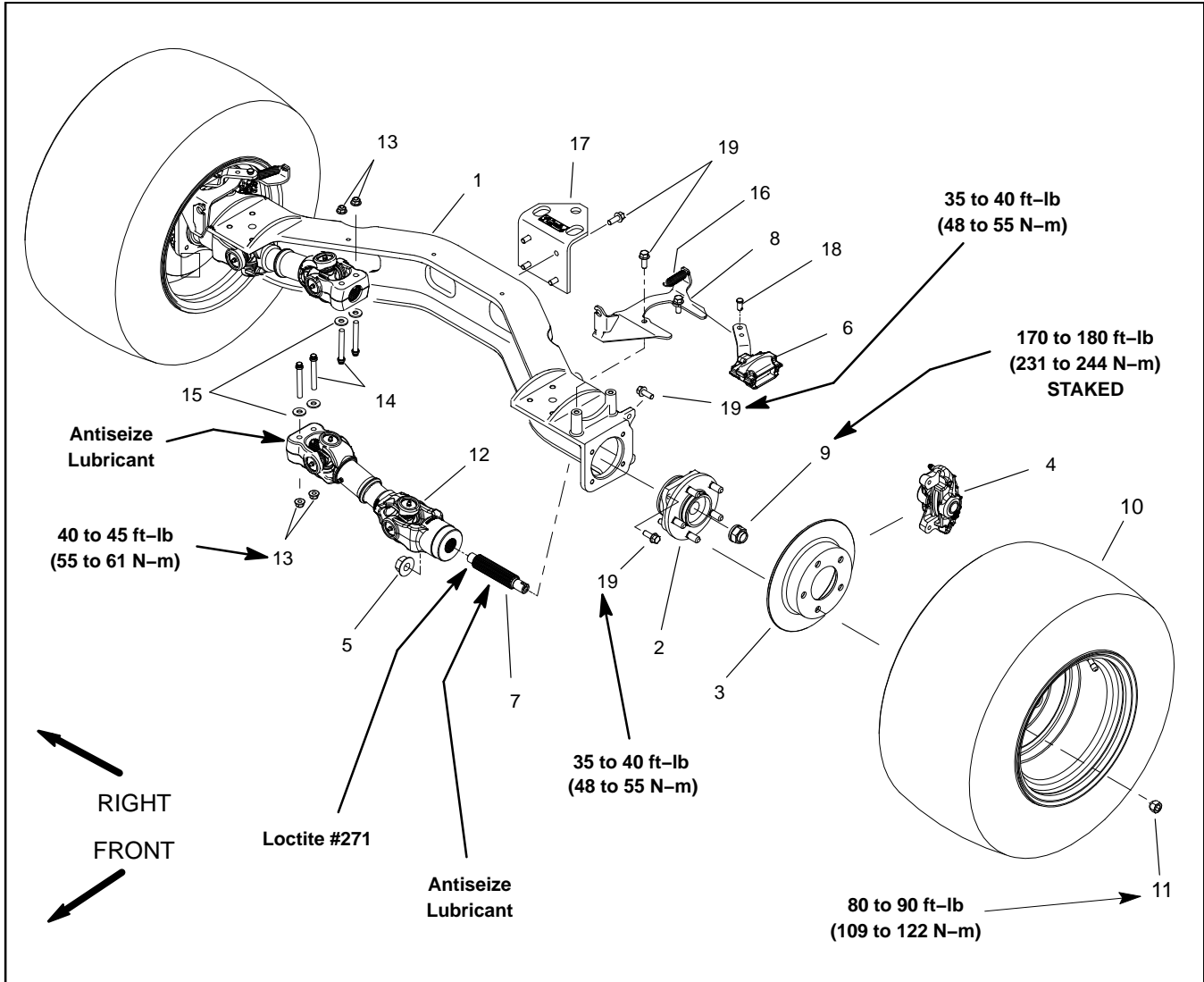

Figure 7

- |                                     |                                     |                                     |
|-------------------------------------|-------------------------------------|-------------------------------------|
| 1. Rear axle                        | 8. Parking brake bracket (LH shown) | 14. Cap screw (2 per shaft)         |
| 2. Wheel hub assembly (2)           | 9. Spindle nut (2)                  | 15. Hardened washer (2 per shaft)   |
| 3. Brake rotor (2)                  | 10. Rear wheel assembly             | 16. Parking brake return spring (2) |
| 4. Brake caliper (LH shown)         | 11. Lug nut (5 per wheel)           | 17. Hitch                           |
| 5. Flange nut (2)                   | 12. Driveshaft assembly (2)         | 18. Clevis pin (2)                  |
| 6. Parking brake caliper (LH shown) | 13. Flange nut (2 per shaft)        | 19. Flange head screw (20)          |
| 7. Splined shaft (2)                |                                     |                                     |

## Removal (Fig. 7)

1. Park vehicle on a level surface, shut engine off and remove key from ignition switch.
2. For driveshaft to be serviced, remove wheel, brake caliper, brake rotor and wheel hub (see Wheel Hub Removal in Chapter 7 - Chassis in this manual).
3. Loosen and remove flange nuts, cap screws and hardened washers that secure driveshaft to transaxle shaft (Fig. 8).
4. Slide driveshaft from transaxle shaft and remove from vehicle.
5. If necessary, loosen and remove flange nut that secures splined shaft to driveshaft. Remove splined shaft from driveshaft.

**NOTE:** Spindle nuts are staked (deformed) to the splined shaft during assembly. Clear away the deformed area of the nut before removing the nut from the shaft or damage to the shaft threads will occur.

## Installation (Fig. 7)

1. If removed, attach splined shaft to driveshaft:
  - A. Apply antiseize lubricant to splined shaft and install into driveshaft.
  - B. Apply Loctite #271 (or equivalent) to threads of splined shaft.
  - C. Install new flange nut onto splined shaft and tighten. Torque spindle nut from **170 to 180 ft-lb (231 to 244 N-m)**.
2. Secure driveshaft to transaxle shaft (Fig. 8):
  - A. Apply antiseize lubricant to transaxle shaft.
  - B. Slide driveshaft yoke onto transaxle shaft.
  - C. Align mounting holes in driveshaft with relief in transaxle shaft.
  - D. Install cap screws, hardened washers and flange nuts to secure driveshaft to transaxle shaft. Torque fasteners from **40 to 45 ft-lb (55 to 61 N-m)**.
3. Install wheel hub, brake rotor, brake caliper and wheel (see Wheel Hub Installation in the Service and Repairs section of Chapter 7 - Chassis). Make sure that wheel lug nuts are properly torqued from **80 to 90 ft-lb (109 to 122 N-m)**.
4. Lubricate driveshaft grease fittings.

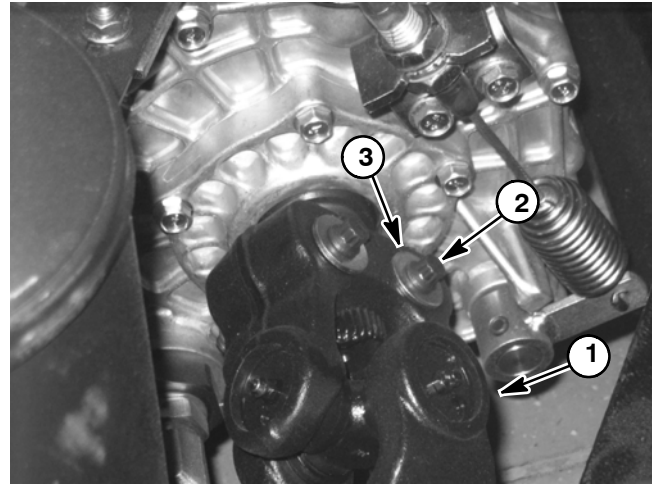

Figure 8

1. Driveshaft
2. Cap screw
3. Hardened washer

## Driveshaft Cross and Bearing Service

1. Remove driveshaft from vehicle (see Driveshaft Removal in this section).

**IMPORTANT: When placing yoke in vise, clamp lightly on the solid part of the yoke to prevent yoke damage. Also, the use of a vise with soft jaws is recommended.**

2. Lightly clamp yoke in vise. Remove snap rings that secure bearings at the inside of each yoke. Remove yoke from vise.

**IMPORTANT: Yokes must be supported when removing and installing bearings to prevent damage.**

3. Use a press to remove cross and bearings from yokes:

A. Place a small socket against one bearing and a large socket against the yoke on the opposite side.

B. While supporting the large socket, apply pressure on small socket to partially push the opposite bearing into the large socket.

C. Remove yoke from press, grasp partially removed bearing and tap on yoke to completely remove the bearing.

D. Repeat process for remaining bearings.

E. Thoroughly clean and inspect all components.

4. To install new cross and bearings:

A. Apply a coating of grease to bearing bores of end yoke and shaft yoke. Also, apply grease to bearings and seal of bearing assembly. Make sure that all bearing rollers are properly seated in bearing cage.

B. Press one bearing partially into yoke.

**IMPORTANT: Take care when installing cross into bearing to avoid damaging bearing seal.**

C. Carefully insert cross into bearing and yoke.

D. Hold cross in alignment and press bearing in until it hits the yoke.

E. Carefully place second bearing into yoke bore and onto cross shaft. Press bearing into yoke.

F. Install snap rings to bearings to secure bearings in place.

G. Repeat procedure for remaining yoke.

5. Lubricate grease fittings until grease purges from bearing cups. Make sure to grease all cross fittings.

6. Make sure that assembled joint moves without binding. Slight binding can usually be eliminated by lightly rapping the yoke lugs with a soft faced hammer. If binding continues, disassemble joint to identify source of binding.

7. Install driveshaft to vehicle (see Driveshaft Installation in this section).

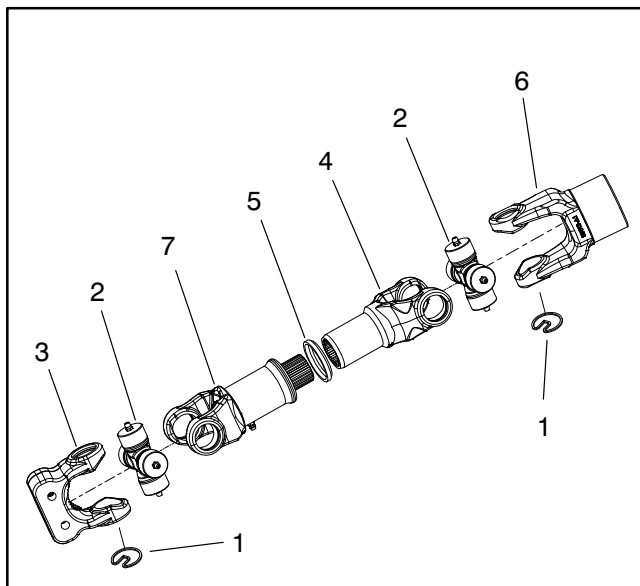

Figure 9

- |                       |              |
|-----------------------|--------------|
| 1. Snap ring          | 5. Seal      |
| 2. Cross and bearings | 6. End yoke  |
| 3. End yoke           | 7. Tube yoke |
| 4. Yoke and hub       |              |



## Power-Take-Off (PTO) Removal & Installation (If Equipped)

### PTO Removal

1. Park vehicle on a level surface, raise and support bed (if installed), shut engine off and engage the parking brake. Remove key from the ignition switch.
2. Remove clevis pin to disconnect PTO control cable clevis from lever arm on PTO. Do not loosen jam nuts to remove cable from support bracket.
3. Disconnect wire harness connector that attaches to PTO switch.
4. Disconnect hydraulic hose from fitting on PTO. Put caps or plugs on open hose and fitting to prevent contamination.
5. Loosen and remove five (5) cap screws and nut with washer that secure PTO to transaxle. Separate PTO and O-ring from transaxle case. Locate and remove two alignment pins.

### PTO Installation

1. Apply multi-purpose grease to O-ring and insert O-ring into groove of transaxle case. Insert two (2) alignment pins in transaxle case.

**IMPORTANT: When installing PTO assembly, make sure O-ring is properly positioned in transaxle case groove.**

2. Install PTO to transaxle. Secure PTO to transaxle with five (5) cap screws and nut with washer. Torque fasteners from **11 to 13 ft-lb (15 to 17 N-m)**.
3. Install hydraulic hose to fitting on PTO.
4. Connect wire harness electrical connector to PTO switch.
5. Adjust PTO control cable (see PTO Cable Adjustment in the Adjustments section of this chapter).

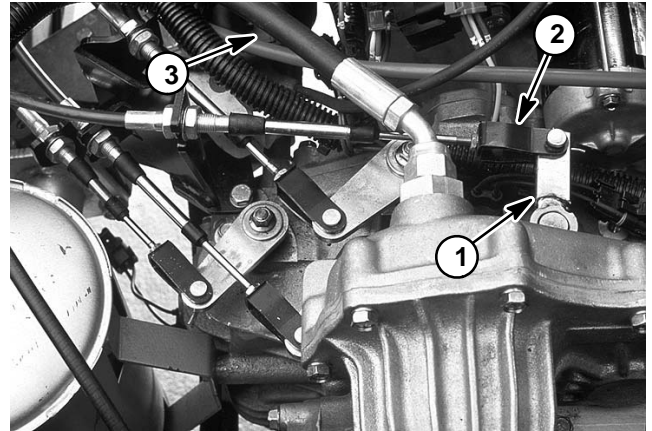

Figure 10

1. PTO lever arm
2. Cable clevis
3. Hydraulic hose

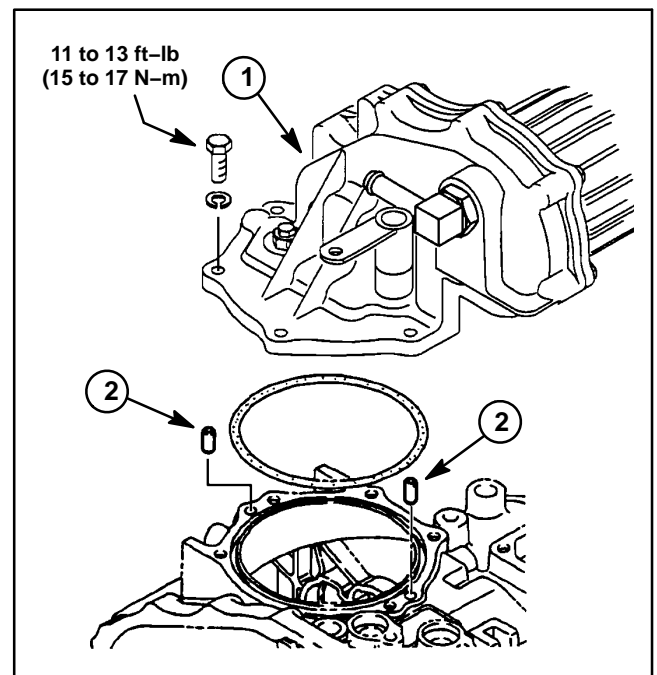

Figure 11

1. PTO assembly
2. Alignment pin

# Transaxle

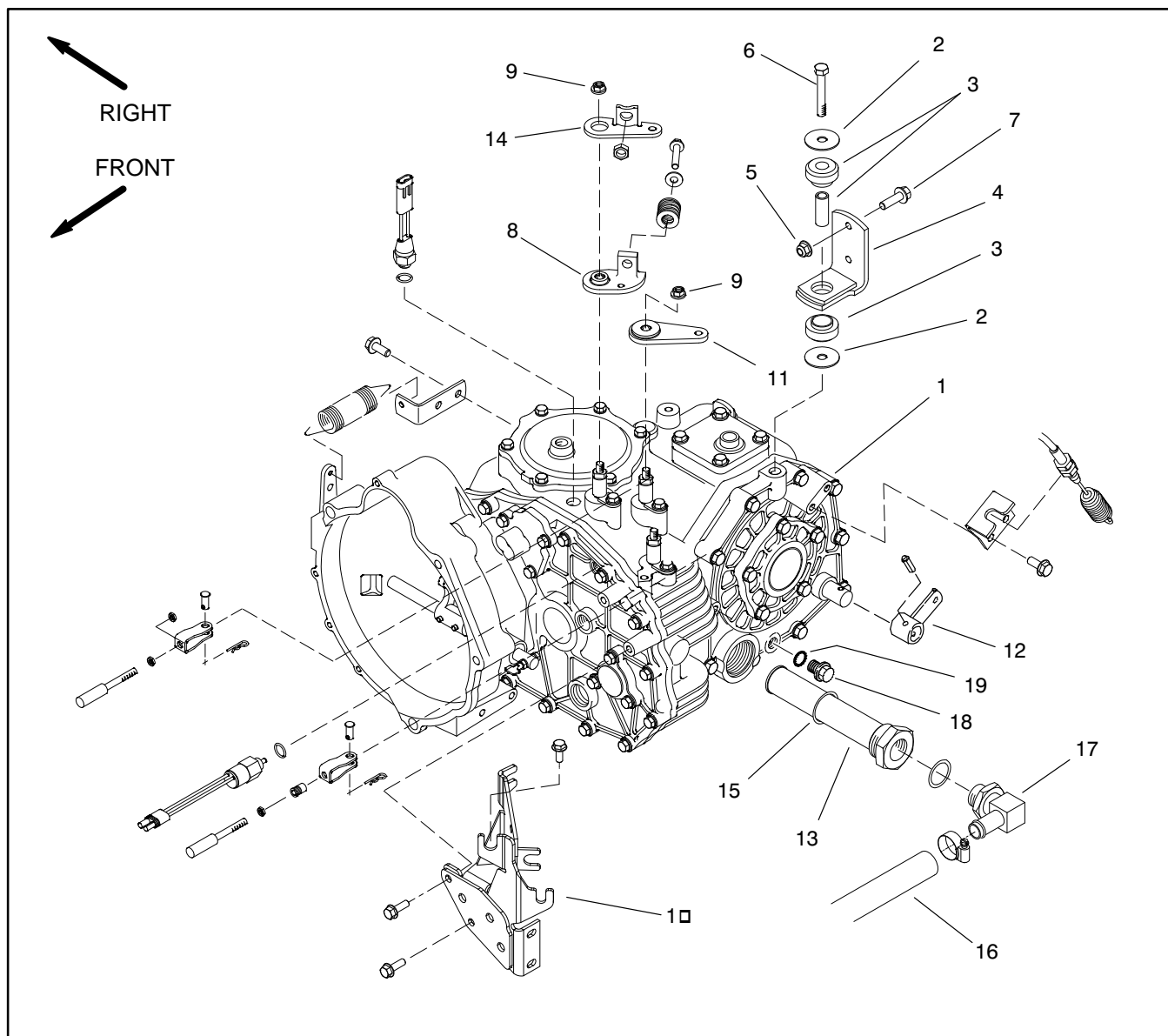

Figure 12

- |                                 |                               |                      |
|---------------------------------|-------------------------------|----------------------|
| 1. Transaxle assembly           | 8. Shift arm                  | 14. Shift arm plate  |
| 2. Snubbing washer (4)          | 9. Lock nut (3)               | 15. O-ring           |
| 3. Isolation mount assembly (2) | 10. Shift cable mount bracket | 16. Suction hose     |
| 4. Transaxle mount (2)          | 11. Shift lever (2)           | 17. 90 elbow fitting |
| 5. Flange nut (4)               | 12. Differential lock lever   | 18. Drain plug       |
| 6. Cap screw (2)                | 13. Strainer                  | 19. O-ring           |
| 7. Flange head screw (4)        |                               |                      |

## Transaxle Removal (Fig. 12)

1. Park vehicle on a level surface. Stop the engine and remove key from ignition switch. Remove the bed or other attachment(s). Allow transaxle and engine to cool.

2. Disconnect negative (-) battery cable from battery first. Then disconnect positive (+) battery cable from battery (see Battery Service in Chapter 8 – Electrical System in this manual).

3. Remove drain plug from bottom of transaxle and allow oil to drain into a suitable drain pan. Install drain plug after draining is complete.

4. Note orientation of 90° fitting connected to strainer on side of transaxle. Remove hydraulic hose and 90° fitting from strainer.

5. Remove muffler (see Muffler Removal in the appropriate Engine Chapter in this manual).

6. Remove hydraulic filter assembly and bracket.

7. Disconnect and label electrical leads that attach to transaxle and PTO (if equipped).

8. Disconnect clutch cable from clutch release lever, then loosen jam nut to remove clutch cable from support bracket (Fig. 13).

9. Loosen jam nut to remove differential lock cable from support bracket, then disconnect differential lock cable from lock lever at left rear of transaxle (Fig. 14).

10. Disconnect shifter control cables from levers on transaxle and PTO (if equipped) (Fig. 15). Do not loosen cable jam nuts at shift cable mount bracket.

11. Remove shift cable mount bracket from transaxle, keeping shifter control cables attached to bracket. Position bracket away from transaxle.

12. On Workman 4WD vehicles, remove differential driveshaft from the transaxle (see Differential Driveshaft Removal in the Service and Repairs section of Chapter 10 – Front Wheel Drive (4WD)).

13. Disconnect return hydraulic hose from transaxle (or PTO if equipped). Put caps or plugs on open hose and fitting to prevent contamination.

14. Remove PTO, if equipped, from top of transaxle (see PTO Removal and Installation in this section).

15. Block front wheels. Jack-up rear of vehicle and install jack stands so transaxle can be removed by sliding out from under rear axle (see Jacking Vehicle in Chapter 1 – Safety in this manual).

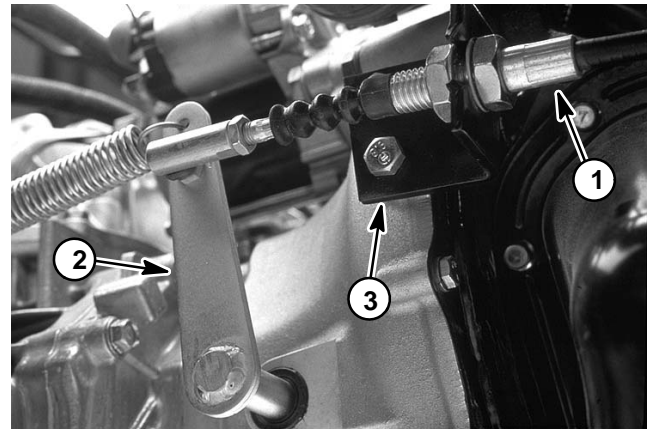

Figure 13

- 1. Clutch cable
- 2. Clutch release lever
- 3. Support bracket



Figure 14

- 1. Differential lock cable
- 2. Differential lock lever

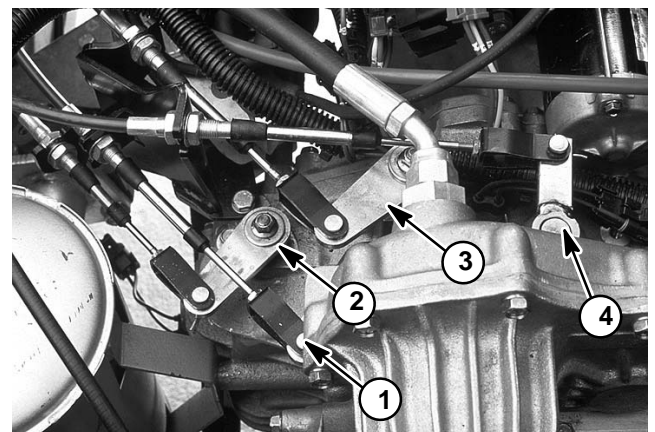

Figure 15

- 1. First-Reverse
- 2. High-Low
- 3. 2nd-3rd
- 4. PTO clutch

16. Put blocking under engine for support. Support transaxle with a floor jack or suspend transaxle from vehicle frame rails.

17. Remove isolation mount assemblies and transaxle mounts (Fig. 16).

18. Remove driveshaft clamp bolts, then slide transaxle side-to-side to disconnect each driveshaft from axle shafts on transaxle.

19. Remove cap screws securing clutch bell housing to engine. Note location of washers and harness brackets.

20. Carefully pull transaxle back to disengage transaxle input shaft from clutch. Use floor jack to lower transaxle and slide out rear of vehicle under the frame.

21. Note location and retrieve two (2) dowel pins from bell housing.

### Transaxle Installation (Fig. 12)

1. To install the transaxle, perform Transaxle Removal procedure in reverse order noting the following:

**IMPORTANT: Workman HD (air cooled, gasoline engine) vehicles require application of silicone sealant to mating surface of bell housing and clutch adapter plate on engine. This will prevent dirt and debris from getting into bell housing and damaging clutch or release bearing.**

A. When installing driveshafts to transaxle, apply antiseize lubricant to transaxle shafts. Align mounting holes in driveshaft with relief in transaxle shaft. Install cap screws, hardened washers and flange nuts to secure driveshaft to transaxle shaft. Torque fasteners from **40 to 45 ft-lb (55 to 61 N-m)**.

B. Before installing two (2) shift levers and shift arm onto transaxle shafts, thoroughly clean tapers of shafts, shift levers and shift arm. Apply Loctite #680 to threads and tapers of shafts. Secure levers and shift arm by torquing nut from **230 to 240 in-lb (26 to 27 N-m)** while holding lever to prevent torque transfer into transaxle (Fig. 18).

2. Install a new hydraulic oil filter and fill transaxle with the Dexron III oil (see vehicle Operator's Manual). Check for oil leaks and repair as necessary.

3. Adjust clutch pedal, shift cables, high-low cable and differential lock cable (see vehicle Operator's Manual).

4. If equipped with PTO, adjust PTO cable (see PTO Cable Adjustment in the Adjustments section of this chapter).

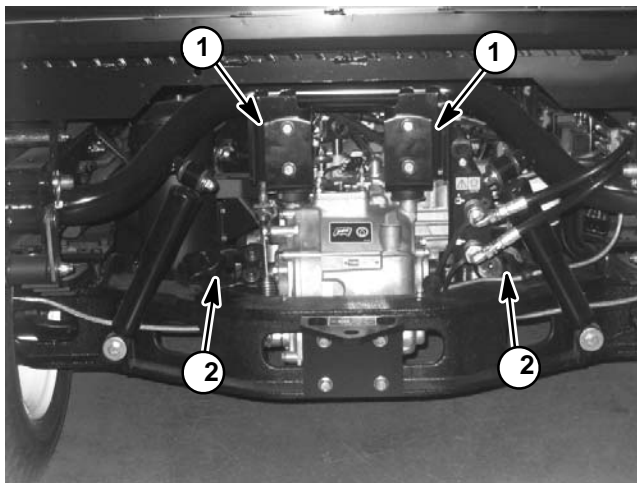

Figure 16

- 1. Transaxle mount
- 2. Driveshaft

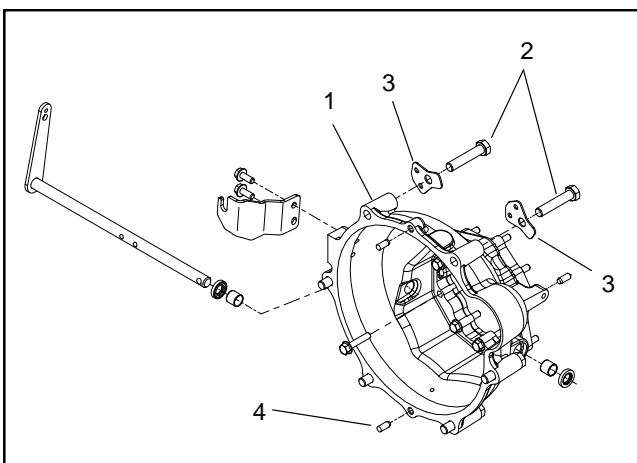

Figure 17

- 1. Bell housing
- 2. Cap screw (6)
- 3. Harness bracket
- 4. Dowel pin (2)

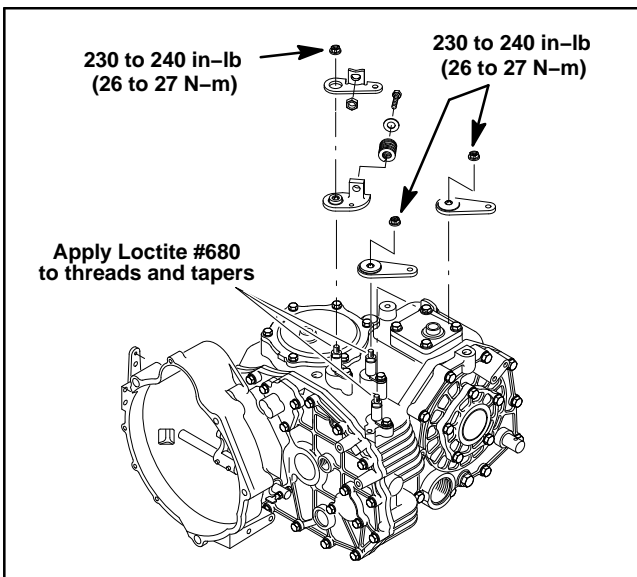

Figure 18

This page is intentionally blank.

## Clutch Service

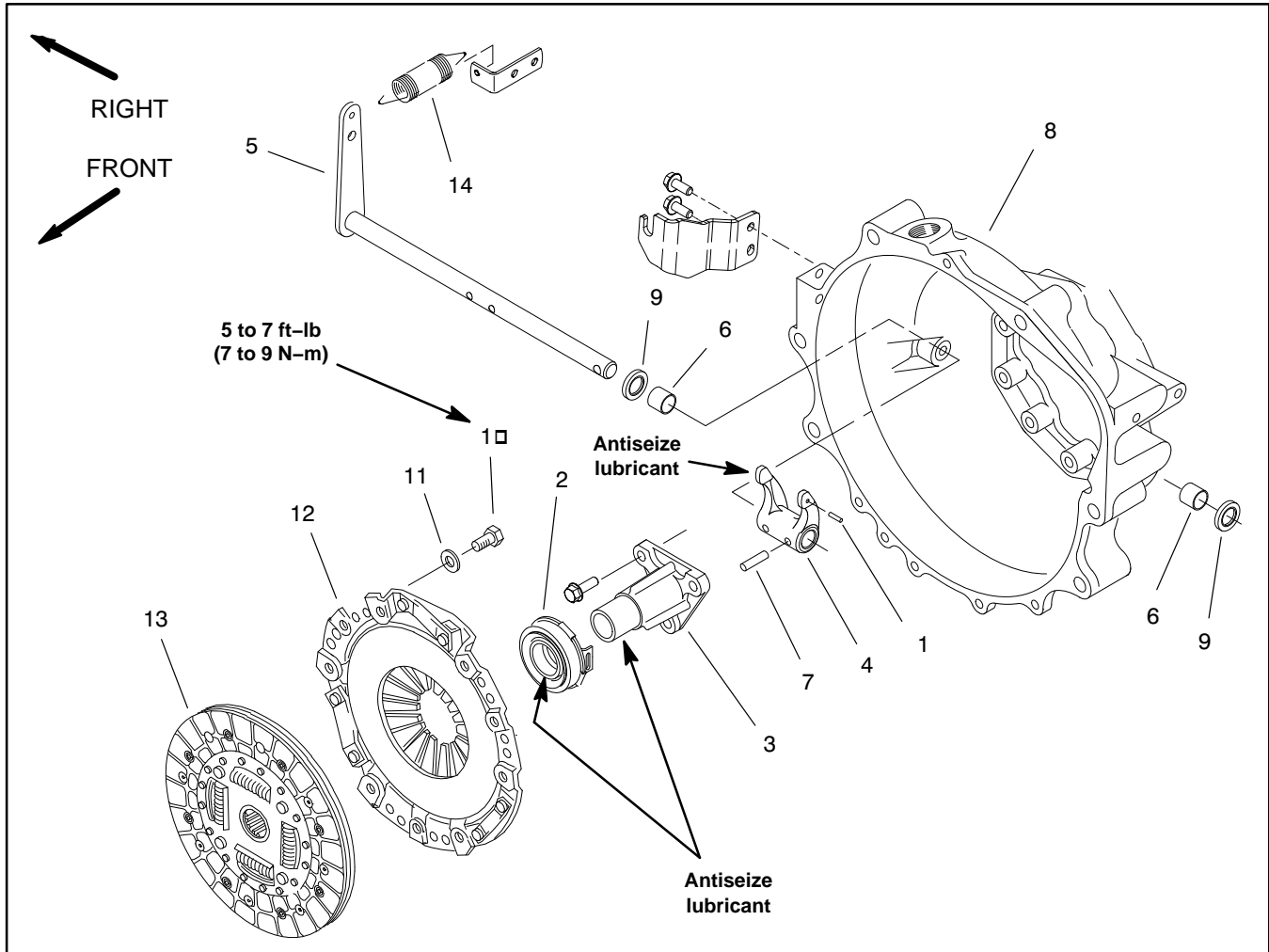

Figure 19

- |                         |                   |                      |
|-------------------------|-------------------|----------------------|
| 1. Spring pin           | 6. Bushing        | 11. Lock washer (6)  |
| 2. Throw out bearing    | 7. Spring pin (2) | 12. Pressure plate   |
| 3. Release guide        | 8. Bell housing   | 13. Clutch disc      |
| 4. Clutch release fork  | 9. Oil seal       | 14. Extension spring |
| 5. Clutch release shaft | 10. Cap screw (6) |                      |

**NOTE:** To perform the following clutch service procedures, the transaxle needs to be removed from vehicle (See Transaxle Removal in this section).

### Clutch Release Mechanism (Fig. 19)

1. Inspect main shaft of transaxle for wear or damaged splines.
2. Remove spring pin, then remove throw out bearing. Inspect bearing and replace if it is loose on the sleeve, if it appears burned or is worn. Make sure bearing slides freely on release guide.
3. Inspect clutch release fork, release shaft and bushings for wear or damage. Inspect extension spring. Replace worn or damaged parts. Replace oil seals.

4. During assembly, apply antiseize lubricant to the following:

- A. Fill inside groove of throw out bearing and coat remainder of bearing bore.
- B. Apply thin coat to outside diameter of release guide.
- C. Apply thin coat to fingers of clutch release fork.
- D. Remove any excess lubricant before final assembly.

### Clutch Disassembly and Inspection (Fig. 19)

1. Insert clutch alignment tool (see Special Tools in this chapter) in engine flywheel pilot bearing hole to keep clutch disk from falling off (Fig. 20).
2. Loosen pressure plate cap screws in a diagonal sequence.
3. Remove cap screws, lock washers and pressure plate, then slide out the alignment tool and remove clutch disk. Note orientation of clutch disk as it is removed (Fig. 21).
4. Inspect diaphragm spring end of pressure plate for wear and uneven height. Replace if wear is evident or if height difference exceeds 0.020 in. (0.5 mm).
5. Check pressure plate surface for wear, cracks or color change.
6. Check strap plate rivets for looseness. Replace pressure plate if rivets are loose.
7. Check clutch disk facing for loose rivets, uneven contact, deterioration due to seizure and lubricant contamination. Replace clutch disk if damaged.
8. Measure rivet sink and replace clutch disk if out of specification (Fig. 23).

Clutch disk thickness standard value	0.307 to 0.339 in. (7.8 to 8.6 mm)
Clutch disk rivet sink	0.012 in. (0.3 mm) minimum

9. Check for torsion spring play or damage. Replace clutch disk if necessary.
10. Install clutch disk on transaxle main shaft. Make sure clutch slides freely on splines of shaft. Check for excessive play in rotating direction.
11. Inspect flywheel surface for stepped wear, streaking or seizure. Replace if necessary. Clean any oil or rust from flywheel surface with light abrasive. Check flywheel runout and replace if runout exceeds 0.005 in. (0.13 mm).
12. Inspect flywheel pilot bearing for wear or damage. Replace pilot bearing if necessary.

### Installing Clutch Disk and Pressure Plate

1. Apply a coating of grease to clutch disk spline, then use a brush to rub it in. Wipe off any excess grease.
2. Use clutch alignment tool (see Special Tools in this chapter) to position clutch disk to engine flywheel.

3. Install pressure plate. Install and tighten six (6) cap screws and lock washers a little at a time, working in a diagonal sequence. Torque screws from **5 to 7 ft-lb (7 to 9 N-m)**. Remove alignment tool from flywheel bearing after pressure plate is installed.

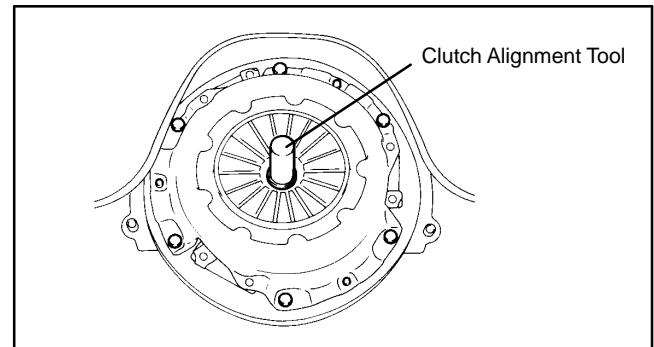

Figure 20

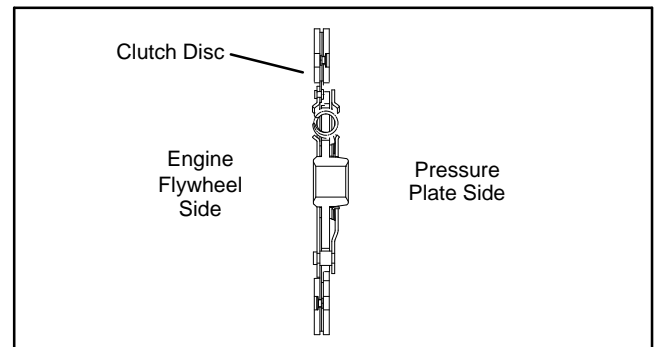

Figure 21

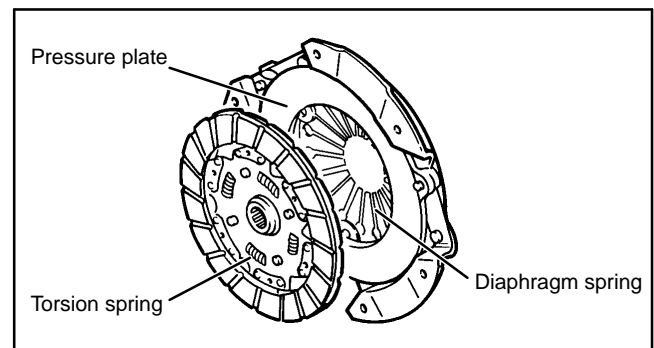

Figure 22

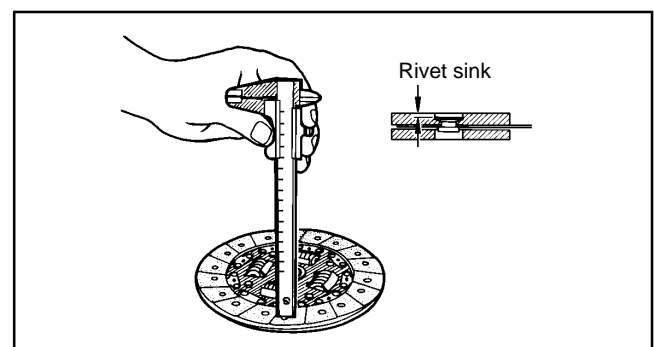

Figure 23

This page is intentionally blank.



## Transaxle Service

### Transaxle Disassembly

**NOTE:** Item numbers in figures are shown in order of disassembly; for example, remove item 1 first, then item 2, etc. assemble transaxle in reverse order; for example, install item 1 last.

1. Remove extension spring.
2. Loosen and remove flange head screws and remove bell housing assembly from transaxle.
3. Thoroughly clean outside surface of transaxle.

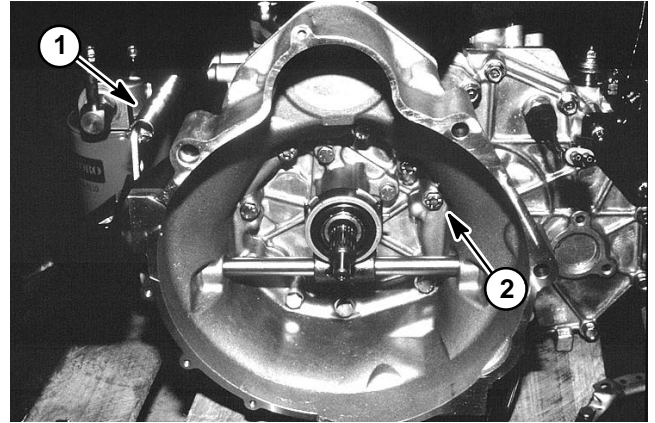

Figure 24

1. Extension

2. Flange hd screw (9)

4. Loosen flange head screws and remove fork shaft case from center plate. Note location of longer flange head screw. Be careful when removing cover as steel balls inside are spring loaded.

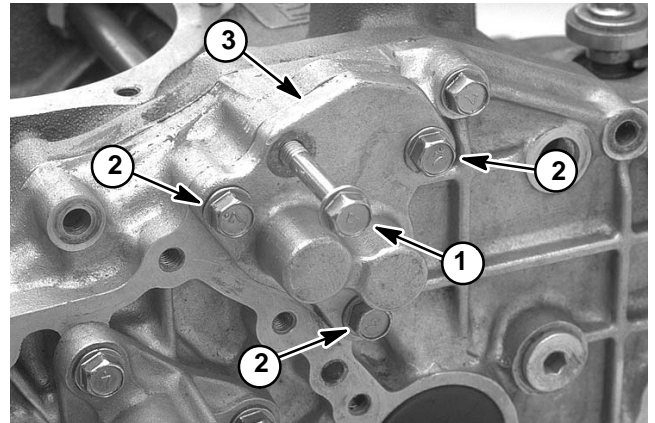

Figure 25

1. Flange head screw (1)  
2. Flange head screw (3)

3. Fork shaft case

5. Hold your hand over the area and shift R-1 and 2-3 levers to move rails outward so balls, springs and spindle can be removed.

6. Inspect fork shaft case for cracks or damage and replace if necessary.

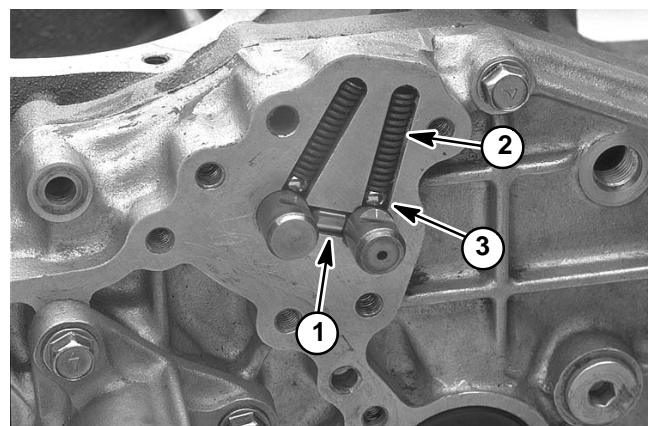

Figure 26

1. Spindle  
2. Spring (2)

3. Ball (2)

7. Loosen and remove fifteen (15) flange head screws and separate center plate from transaxle case. Note dowel pins in transaxle case. Remove seal cap, shims and snap ring from center plate.

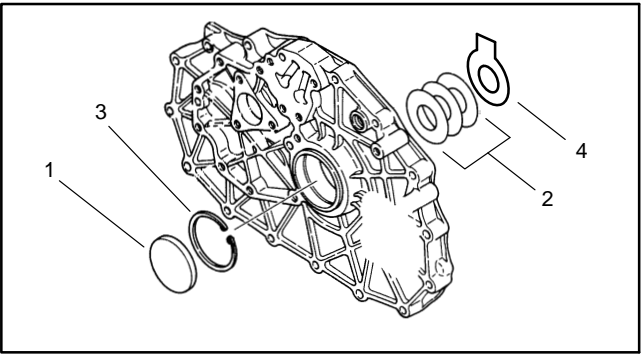

Figure 27

- 1. Seal cap
- 2. Shims
- 3. Shim
- 4. Snap ring

8. 4WD UNITS ONLY: remove front drive shaft and 41T gear from the gear case. Remove bearings from gear case and center plate (Fig. 28 and Fig. 29).

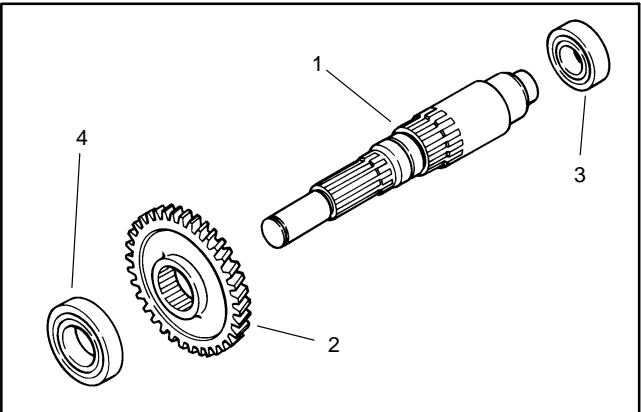

Figure 28

- 1. Front drive shaft
- 2. 41T gear
- 3. Bearing (gear case)
- 4. Bearing (center plate)

9. Remove reverse shaft from transaxle case.

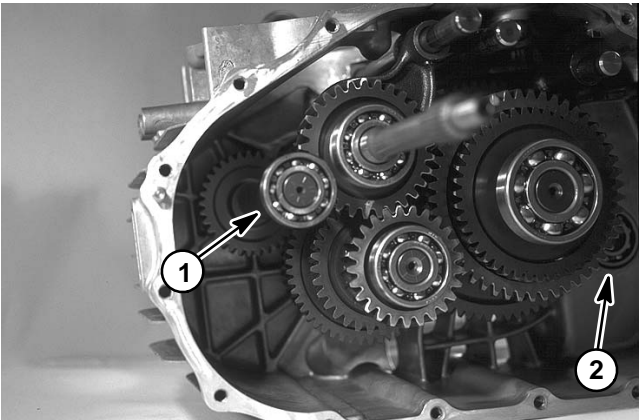

Figure 29

- 1. Reverse shaft
- 2. Bearing (gear case)

10. Remove main shaft assembly together with fork shaft assembly from transaxle case.

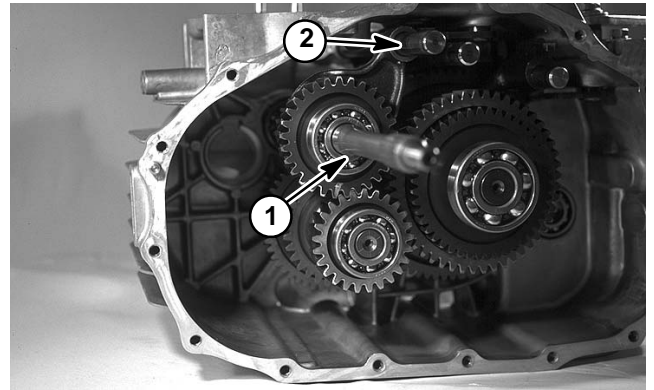

Figure 30

- 1. Main shaft assembly
- 2. Fork shaft assembly

11. Remove, all at the same time, reduction shaft assembly, 2nd–3rd shift assembly, countershaft assembly and High–Low shift assembly.

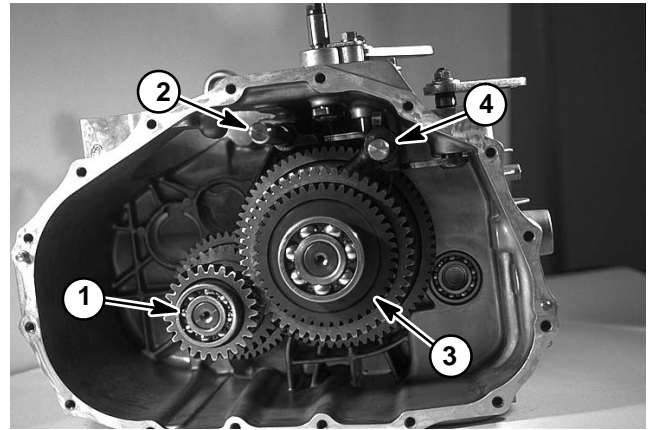

Figure 31

- 1. Reduction shaft assembly
- 2. 2<sup>nd</sup>–3rd shaft assembly
- 3. Countershaft assembly
- 4. High–Low shift assembly

12. Loosen flange head screws and remove L.H. axle shaft assembly and shims from L.H. side cover still attached to transaxle.

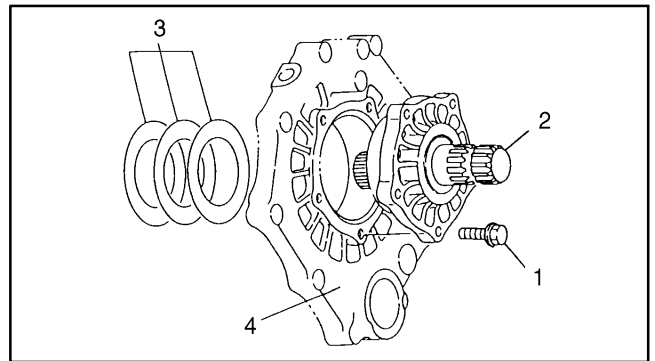

Figure 32

- 1. Flange head screw (5)
- 2. L.H. axle shaft assembly
- 3. Shims
- 4. L.H. Side cover

13. Remove roll pin from differential lock lever. Remove lever from shaft. Loosen and remove five (5) flange head screws. Remove L.H. side cover from transaxle case.

14. Inspect side cover for cracks or damage and replace if necessary.

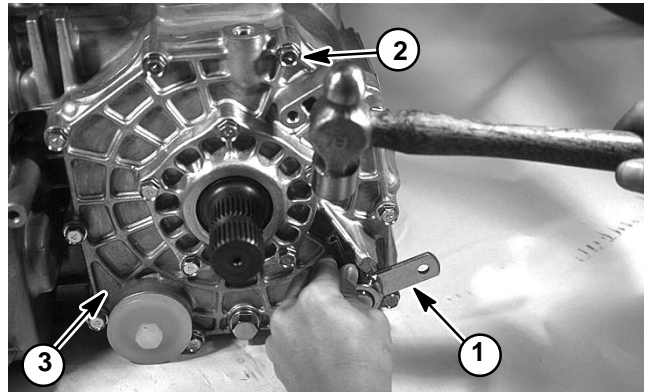

Figure 33

- 1. Lever
- 2. Flange head screw (5)
- 3. L.H. Side cover

15. Loosen and remove four (4) flange head screws. Remove R.H. axle shaft assembly from transaxle case.

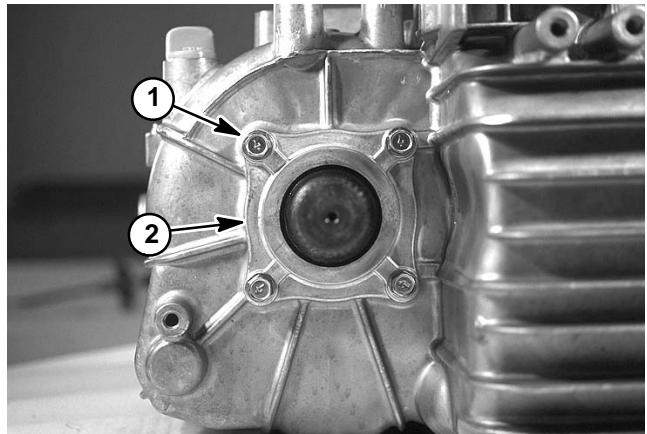

Figure 34

- 1. Flange head screw (4)
- 2. R.H. Axle shaft assy.

16. Remove differential gear assembly together with fork shaft assembly.

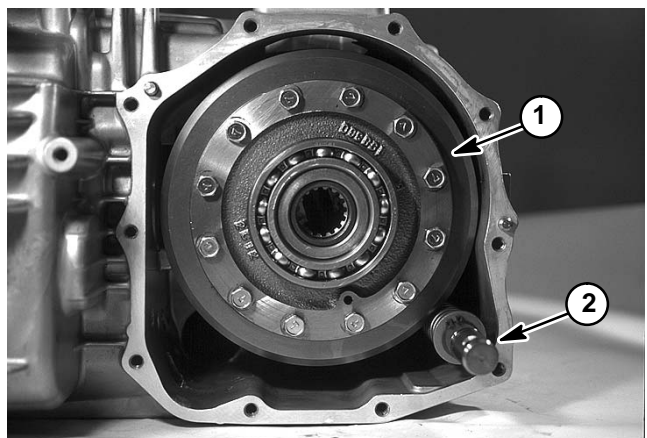

Figure 35

- 1. Differential gear assy.
- 2. Fork shaft assy.

17. Remove washer from inside of transaxle case.  
 NOTE: Washer may stick to fork shaft when removed in step 16.

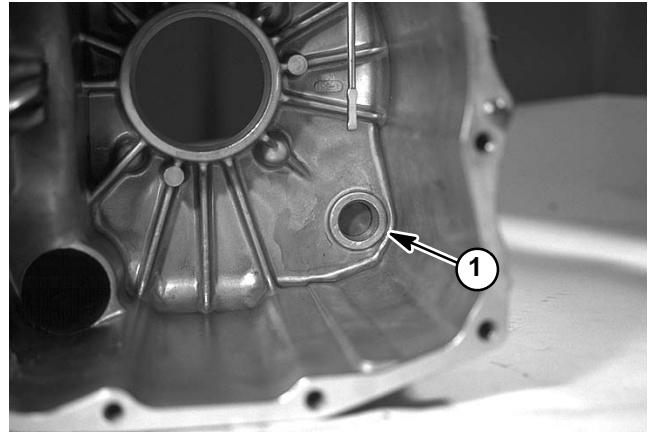

Figure 36  
 1. Washer

18. To remove shift arms:

A. Loosen and remove nut. Remove 2nd–3rd shift arm together with shift arm plate, spring, lock nut, washer and cap screw.

B. Loosen and remove lock nut from both 1st–Rev. shift arm and High–Low shift arm (not shown). Remove shift arms.

C. Loosen cap screws (Fig. 38) and remove keeper plates.

D. Remove oil seals.

E. Inspect shift arms and keeper plates for bending or damage and replace if necessary.

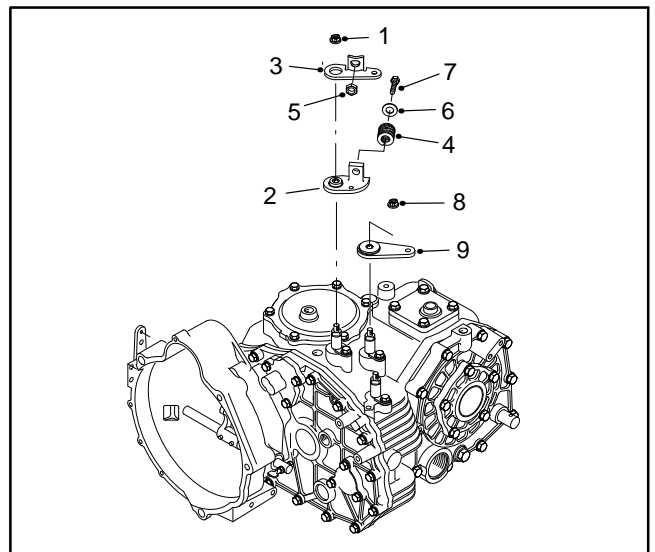

Figure 37

- |   |                      |
|---|----------------------|
| 1. Nut  | 6. Washer            |
| 2. 2 <sup>nd</sup> –3 <sup>rd</sup> shift arm | 7. Cap screw         |
| 3. Shift arm plate                            | 8. Lock nut          |
| 4. Spring                                     | 9. 1st–Rev shift arm |
| 5. Lock nut                                   |                      |

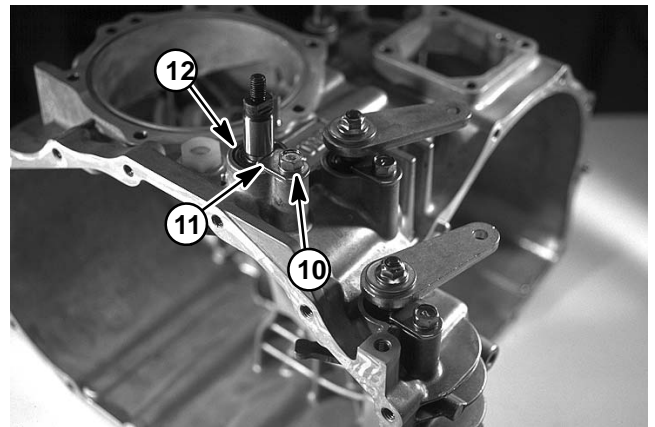

Figure 38

- |                  |              |
|------------------|--------------|
| 10. Cap screw    | 12. Oil seal |
| 11. Keeper plate |              |

19.If PTO cover is on transaxle, remove cap screws and nut with washer. Separate PTO cover from transaxle case. Inspect PTO cover for cracks or damage and replace if necessary.

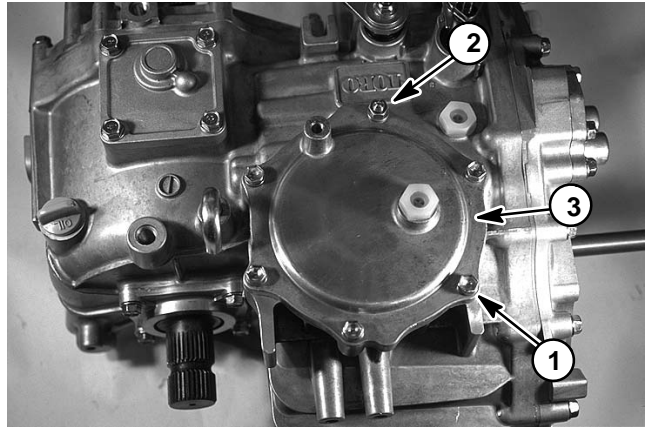

Figure 39

- 1. Cap screw (5)
- 2. Nut
- 3. PTO cover

20.Remove oil cap and O-ring from transaxle case if necessary.

21.Remove air breather if necessary.

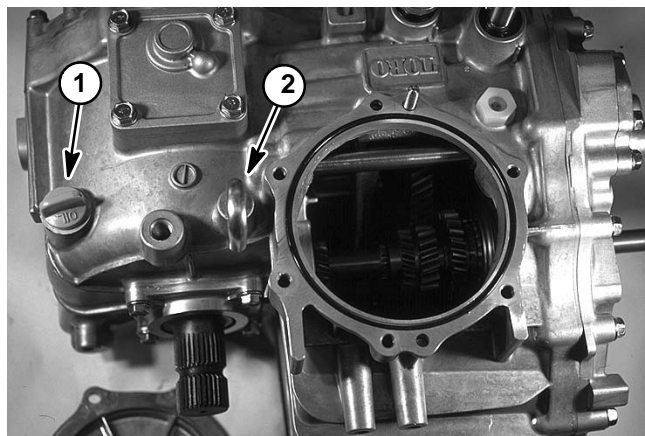

Figure 40

- 1. Oil cap
- 2. Air breather

22.Loosen flange head screws and remove upper cover from transaxle case.

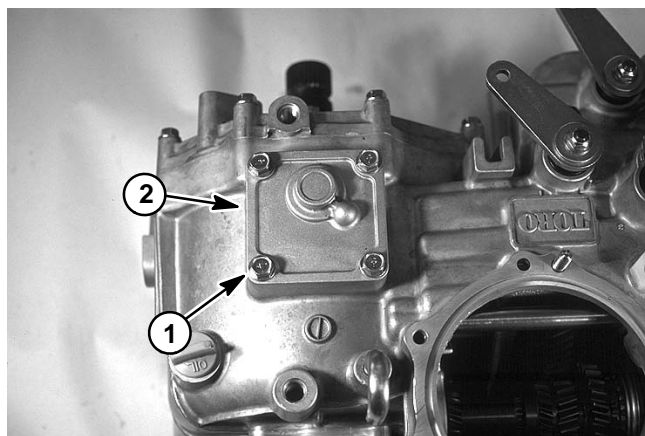

Figure 41

- 1. Flange head screw (4)
- 2. Upper cover

23. Disassemble main shaft assembly:

- A. Use a bearing puller to remove bearing from main shaft.
- B. Remove snap ring and washer. Measure thickness of washer. Replace washer if it is less than 0.0709 in. (1.8 mm) thick.
- C. Remove needle bearings and gear (item 4). Inspect needle bearings and replace if necessary.
- D. Remove synchro ring.
- E. Remove snap ring.
- F. Remove shifter together with spring, hub and keys.
- G. Remove key (item 9).
- H. Remove snap ring.
- I. Remove synchro ring, gear (item 11), needle bearings and washer. Inspect needle bearings and replace if necessary.
- J. Use a bearing puller to remove bearing (item 14).
- K. Remove remaining gears and snap ring.

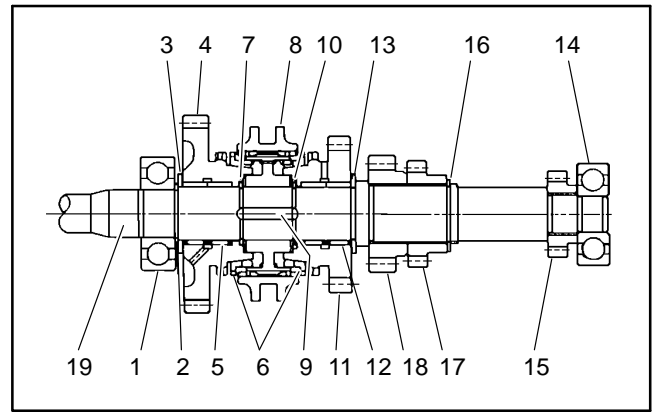

Figure 42

- |                       |                        |
|-----------------------|------------------------|
| 1. Bearing            | 11. Gear               |
| 2. Snap ring          | 12. Needle bearing (2) |
| 3. Washer             | 13. Washer             |
| 4. Gear               | 14. Bearing            |
| 5. Needle bearing (2) | 15. Gear               |
| 6. Synchro ring       | 16. Snap ring          |
| 7. Snap ring          | 17. Gear               |
| 8. Shifter            | 18. Gear               |
| 9. Key                | 19. Main shaft         |
| 10. Snap ring         |                        |

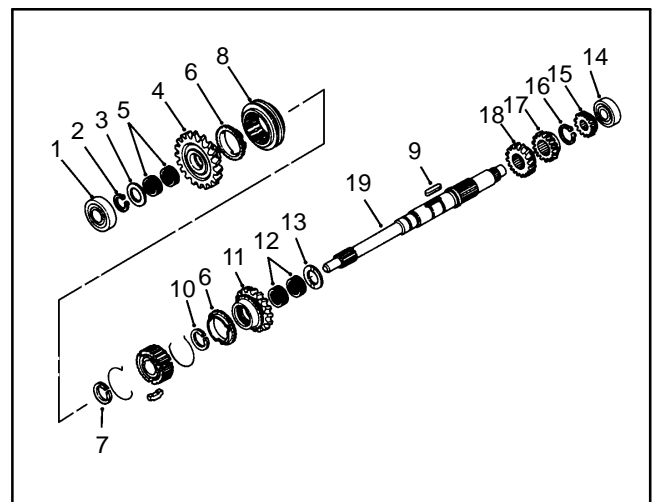

Figure 43

- |                       |                        |
|-----------------------|------------------------|
| 1. Bearing            | 11. Gear               |
| 2. Snap ring          | 12. Needle bearing (2) |
| 3. Washer             | 13. Washer             |
| 4. Gear               | 14. Bearing            |
| 5. Needle bearing (2) | 15. Gear               |
| 6. Synchro ring       | 16. Snap ring          |
| 7. Snap ring          | 17. Gear               |
| 8. Shifter            | 18. Gear               |
| 9. Key                | 19. Main shaft         |
| 10. Snap ring         |                        |

24. Disassemble reduction shaft assembly:

- A. Use a bearing puller to remove bearing from reduction shaft.
- B. Remove gear, helical gear, collar and gear.
- C. Use a bearing puller to remove bearing.
- D. Remove washer, needle bearing and gear.
- E. Remove spacer.
- F. Remove snap ring.
- G. Remove shifter together with spring, hub and keys.
- H. Remove key.
- I. Remove synchro ring from gear.
- J. Remove gear, needle bearing and thrust washer. Inspect needle bearing and replace if necessary. Measure thickness of thrust washer. Replace thrust washer if thickness is less than 0.0709 in. (1.8 mm).

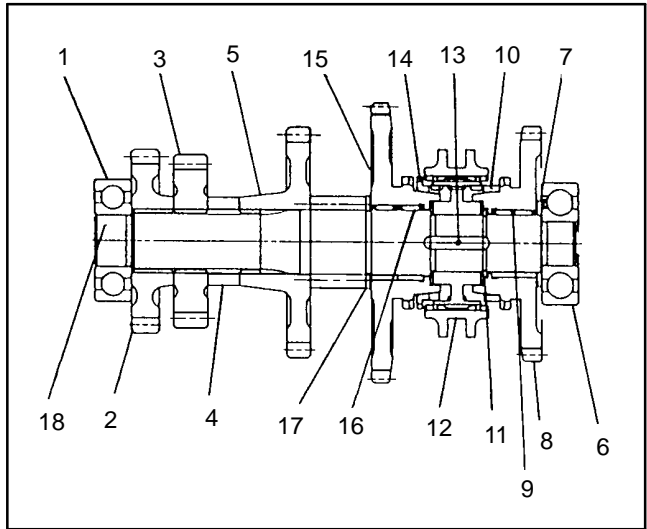

Figure 44

- |                   |                     |
|-------------------|---------------------|
| 1. Bearing        | 10. Spacer          |
| 2. Gear           | 11. Snap ring       |
| 3. Helical gear   | 12. Shifter         |
| 4. Collar         | 13. Key             |
| 5. Gear           | 14. Synchro ring    |
| 6. Bearing        | 15. Gear            |
| 7. Washer         | 16. Needle bearing  |
| 8. Gear           | 17. Thrust washer   |
| 9. Needle bearing | 18. Reduction shaft |

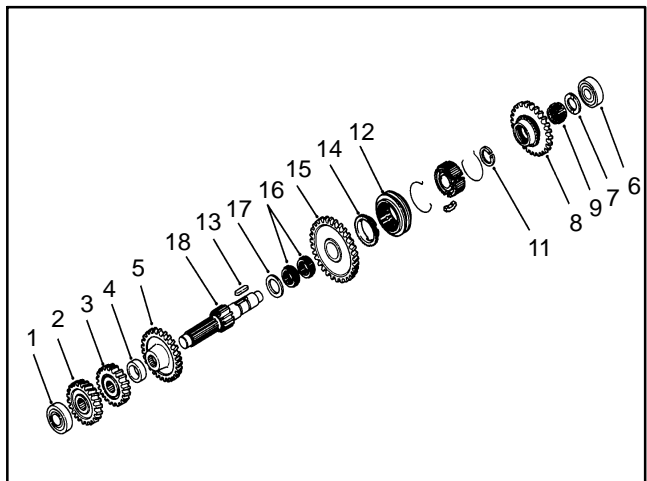

Figure 45

- |                   |                     |
|-------------------|---------------------|
| 1. Bearing        | 10. Spacer          |
| 2. Gear           | 11. Snap ring       |
| 3. Helical gear   | 12. Shifter         |
| 4. Collar         | 13. Key             |
| 5. Gear           | 14. Synchro ring    |
| 6. Bearing        | 15. Gear            |
| 7. Washer         | 16. Needle bearing  |
| 8. Gear           | 17. Thrust washer   |
| 9. Needle bearing | 18. Reduction shaft |



25. Disassemble reverse shaft assembly:

- A. Use a bearing puller to remove bearing from reverse shaft.
- B. Remove gear.
- C. Use a bearing puller to remove bearing from reverse shaft.

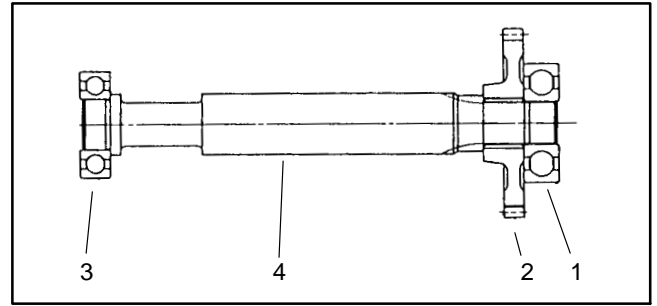

Figure 46

- |            |                  |
|------------|------------------|
| 1. Bearing | 3. Bearing       |
| 2. Gear    | 4. Reverse shaft |

26. Disassemble countershaft assembly:

- A. Use a bearing puller to remove bearing from countershaft.
- B. Remove thrust washer and snap ring.
- C. Remove thrust washer and gear.
- D. Remove inner race and thrust washer. Inspect inner race for wear and damage. Replace inner race if O.D. is less than 1.258 in. (31.95 mm). Measure thickness of thrust washer. Replace thrust washer if thickness is less than 0.0709 in. (1.8 mm).
- E. Remove snap rings.
- F. Remove Hi-Lo shifter and collar spline.
- G. Remove gear. Inspect bushing for wear and damage. Replace gear if I.D. exceeds 1.184 in. (30.08 mm).
- H. Remove washer, snap ring and collar. Measure thickness of washer and replace washer if thickness is less than 0.110 in. (2.8 mm)
- I. Use a bearing puller to remove remaining bearings.

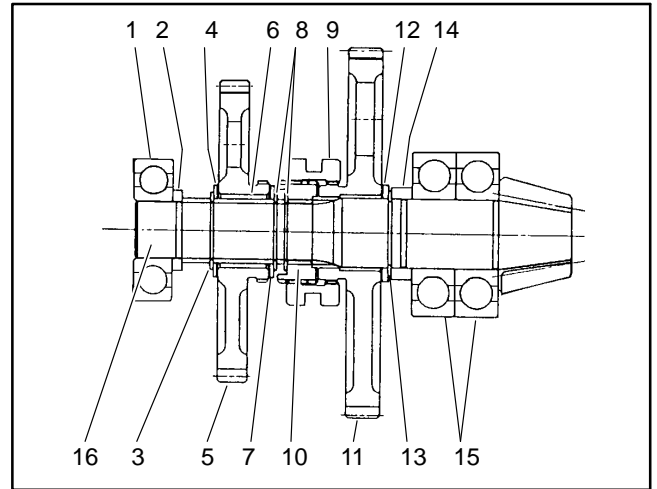

Figure 47

- |                  |                   |
|------------------|-------------------|
| 1. Bearing       | 9. Hi-Lo shifter  |
| 2. Thrust washer | 10. Collar spline |
| 3. Snap ring     | 11. Gear          |
| 4. Thrust washer | 12. Washer        |
| 5. Gear          | 13. Snap ring     |
| 6. Inner race    | 14. Collar        |
| 7. Thrust washer | 15. Bearing (2)   |
| 8. Snap ring (2) | 16. Countershaft  |

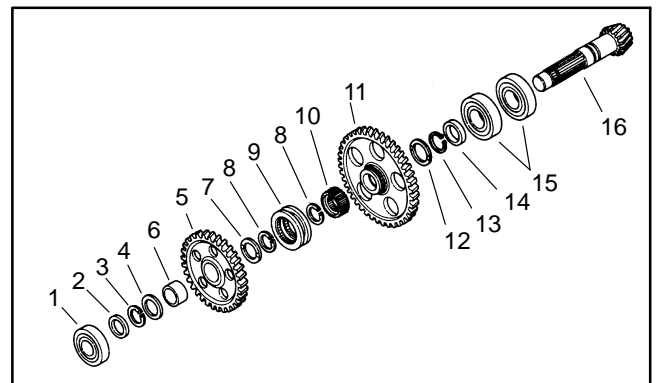

Figure 48

- |                  |                   |
|------------------|-------------------|
| 1. Bearing       | 9. Hi-Lo shifter  |
| 2. Thrust washer | 10. Collar spline |
| 3. Snap ring     | 11. Gear          |
| 4. Thrust washer | 12. Washer        |
| 5. Gear          | 13. Snap ring     |
| 6. Inner race    | 14. Collar        |
| 7. Thrust washer | 15. Bearing (2)   |
| 8. Snap ring (2) | 16. Countershaft  |

27. Disassemble fork shaft assemblies:

- A. Remove lock pin from 2nd–3rd fork shaft assembly.
- B. Note or mark mating shafts and forks for assembly.
- C. Remove shift fork from fork shaft.
- D. Remove lock pin from 1st–R fork shaft assembly.
- E. Remove shift fork from fork shaft.

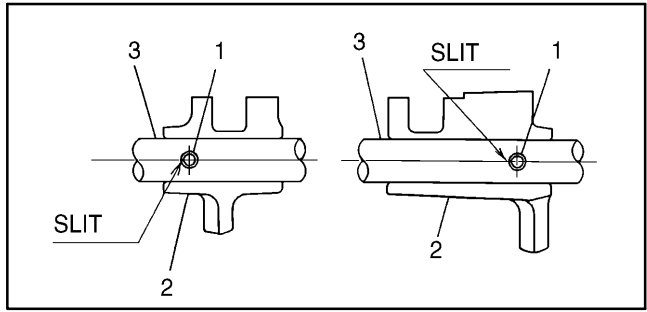

Figure 49

- 1. Lock pin
- 2. Shift fork
- 3. Fork shaft

28. Disassemble Hi–Lo fork shaft assembly:

- A. Remove shift fork, steel ball and spring from Hi–Lo shift fork assembly.
- B. Remove E–ring.

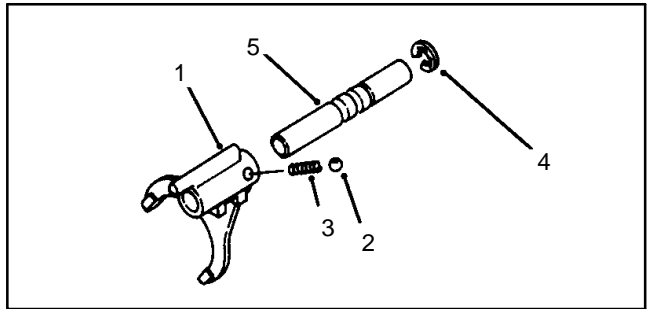

Figure 50

- 1. Shift fork
- 2. Steel ball
- 3. Spring
- 4. E-ring
- 5. Hi–Lo fork shaft

29. Disassemble differential gear assembly:

- A. Use a bearing puller to remove bearing (item 1) from differential case.
- B. Remove snap ring.
- C. Use a bearing puller to remove bearing and slider.
- D. Loosen screws from ring gear.
- E. Remove ring gear from differential case and remove dowel pins.
- F. Drive lock pin out of pinion shaft.
- G. Remove pinion shaft from differential case.
- H. Remove differential pinions and liners.
- I. Remove L.H. side gear, R.H. side gear and liners.

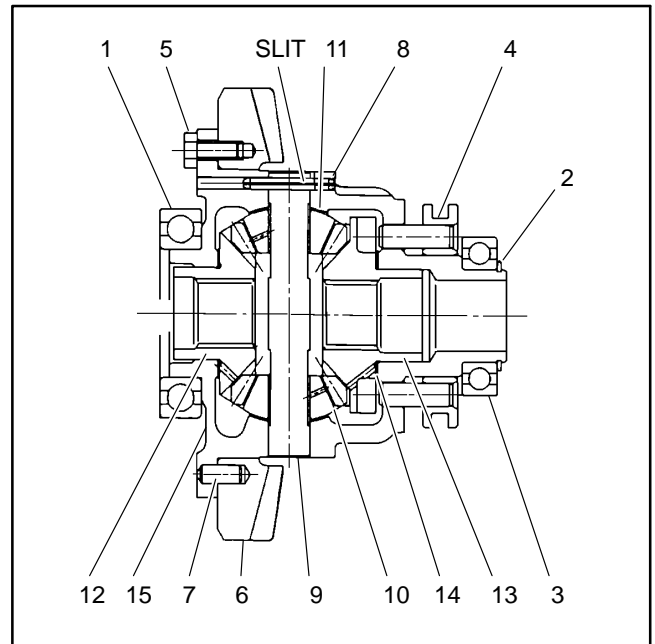

Figure 51

- |                  |                    |
|------------------|--------------------|
| 1. Bearing       | 8. Lock pin        |
| 2. Snap ring     | 9. Pinion shaft    |
| 3. Bearing       | 10. Pinion (2)     |
| 4. Slider        | 11. Liner (2)      |
| 5. Screws        | 12. L.H. side gear |
| 6. Ring gear     | 13. R.H. Side gear |
| 7. Dowel pin (2) | 14. Liner (2)      |

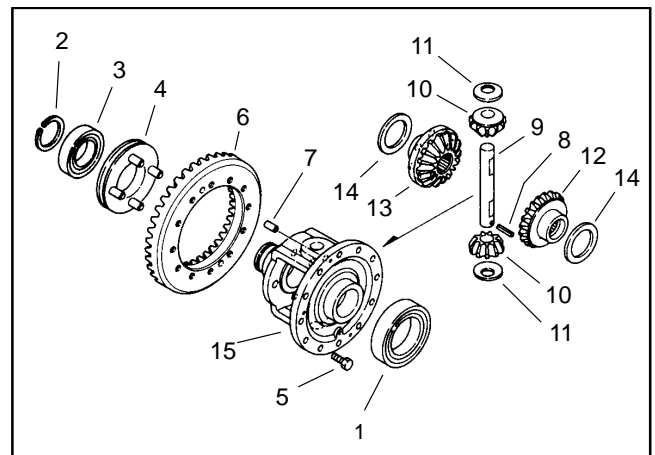

Figure 52

- |                  |                    |
|------------------|--------------------|
| 1. Bearing       | 8. Lock pin        |
| 2. Snap ring     | 9. Pinion shaft    |
| 3. Bearing       | 10. Pinion (2)     |
| 4. Slider        | 11. Liner (2)      |
| 5. Screws        | 12. L.H. side gear |
| 6. Ring gear     | 13. R.H. Side gear |
| 7. Dowel pin (2) | 14. Liner (2)      |

30. Disassemble differential fork shaft assembly:

- A. Remove O-ring from fork shaft.
- B. Remove snap ring, washer and spring.
- C. Remove fork.
- D. Remove lock pin if necessary.

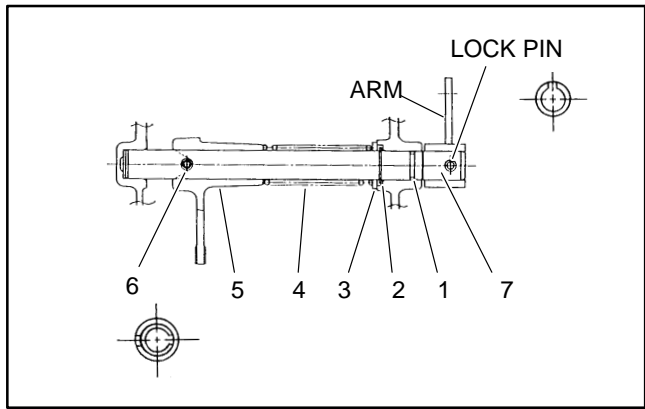

Figure 53

- |              |               |
|--------------|---------------|
| 1. O-ring    | 5. Fork       |
| 2. Snap ring | 6. Lock pin   |
| 3. Washer    | 7. Fork shaft |
| 4. Spring    |               |

31. Disassemble L.H. axle shaft:

- A. Remove O-ring from differential carrier.
- B. Remove snap ring.
- C. Remove L.H. axle shaft assembly.
- D. Remove snap ring and washer.
- E. Use a bearing puller to remove bearing from axle shaft.
- F. Remove oil seal from differential carrier.

32. Disassemble R.H. axle shaft:

- G. Remove R.H. axle shaft assembly from seal cover.
- H. Remove snap ring and washer from axle shaft.
- I. Use a bearing puller to remove bearing.
- J. Remove washer and oil seal from seal cover.

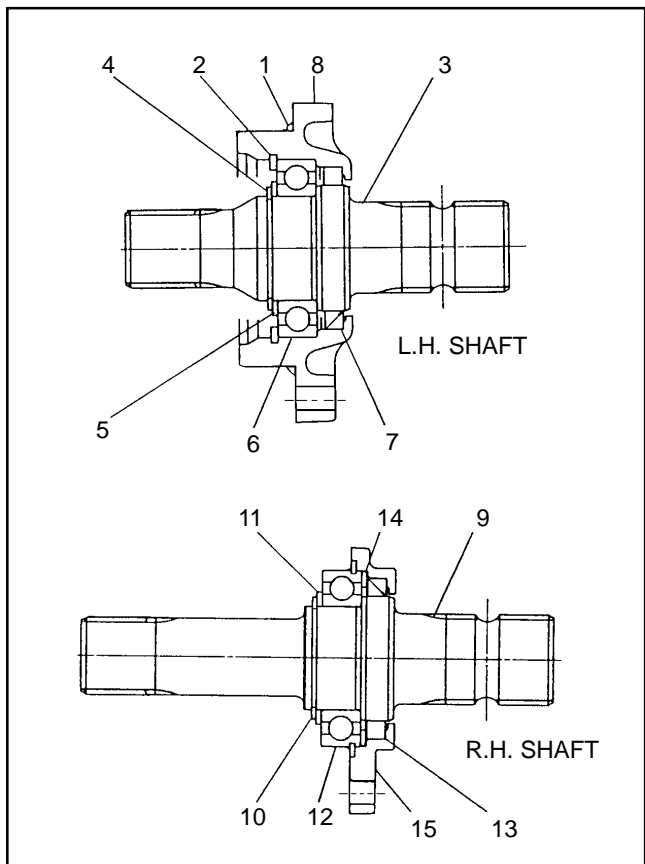

Figure 54

- |                             |                             |
|-----------------------------|-----------------------------|
| 1. O-ring                   | 9. R.H. axle shaft assembly |
| 2. Snap ring                | 10. Snap ring               |
| 3. L.H. axle shaft assembly | 11. Washer                  |
| 4. Snap ring                | 12. Bearing                 |
| 5. Washer                   | 13. Oil seal                |
| 6. Bearing                  | 14. Washer                  |
| 7. Oil seal                 | 15. Seal cover              |
| 8. Differential carrier     |                             |

## Transaxle Inspection

1. Thoroughly clean and dry all parts.
2. Use emery cloth to remove nicks and burrs from all parts.
3. Inspect synchronizer ring:
  - A. Inspect the chamfer for excessive wear or damage.
  - B. Inspect inner tapered area for excessive wear or damage.
  - C. Measure the clearance between synchronizer ring and synchro gear in three equally spaced points. If clearance is less than 0.0195 in. (0.5 mm) replace the synchronizer ring.

4. Inspect synchro gears:

- A. Inspect the cone surface for roughness, material transfer (brass color material) or damage.
- B. Inspect the spline chamfer for excessive chipping or damage.
- C. Inspect I.D. of synchro gear for excessive wear or scoring. If synchro gears have the following I.D., replace the synchro gear:

22T, 25T, 40T	I.D. exceeds 1.027 in. (26.08 mm)
49T	I.D. exceeds 1.145 in. (29.08 mm)

5. 4WD UNITS ONLY: inspect 41T gear and front drive shaft:

- A. Inspect gear teeth for roughness, material transfer (brass color material) or damage.
- B. Inspect spline chamfer for excessive chipping or damage.
- C. Inspect I.D. of gear for excessive wear or scoring. Gear should fit snugly on shaft.

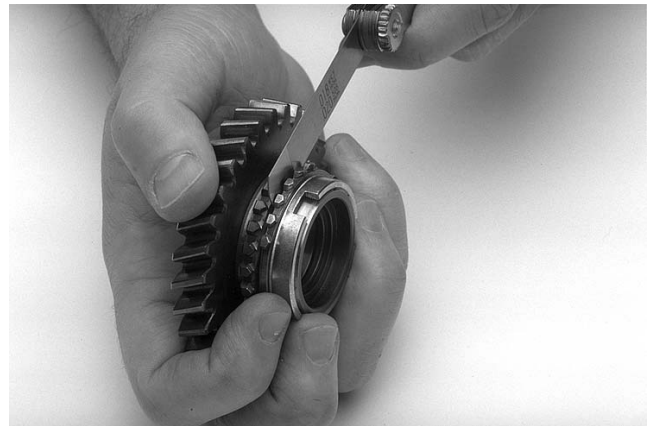

Figure 55

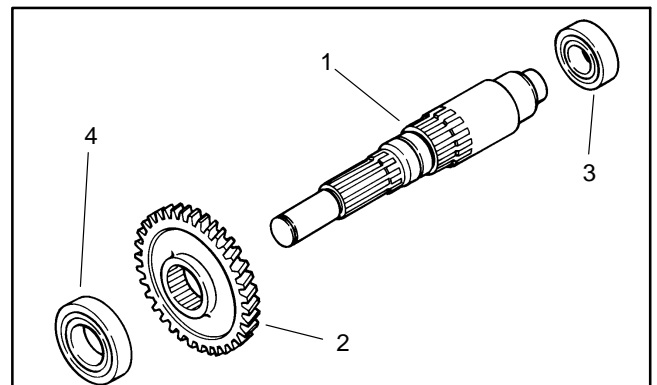

Figure 56

- |                      |                           |
|----------------------|---------------------------|
| 1. Front drive shaft | 3. Bearing (gear case)    |
| 2. 41T gear          | 4. Bearing (center plate) |

6. Inspect hub, shifter, synchro key and synchro spring:
  - A. Inspect hub for worn or damaged spline.
  - B. Inspect shifter for chipping or damaged chamfer.
  - C. Inspect synchro keys for wear or damage.
  - D. Inspect synchro springs for wear or damage.
  - E. The shifter should move freely on the hub.
  - F. Measure the clearance between shifter groove and fork. Replace shift fork, if the clearance exceeds 0.039 in. (1.0 mm).

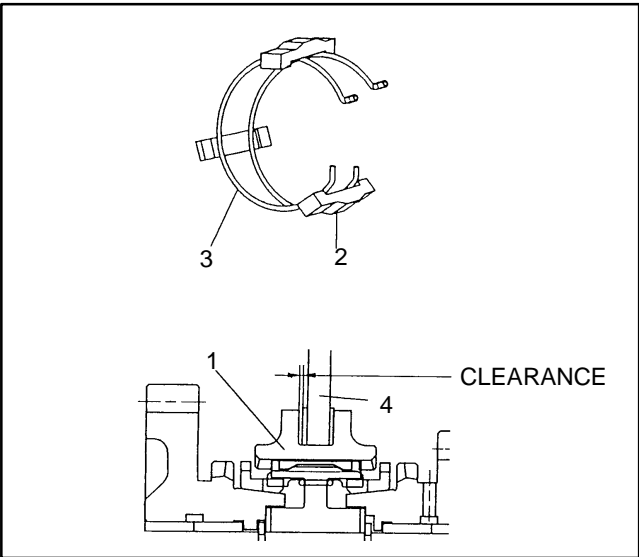

Figure 57

- |            |           |
|------------|-----------|
| 1. Shifter | 3. Spring |
| 2. Key (3) | 4. Fork   |

7. Inspect main shaft:
  - A. Inspect main shaft for worn or damaged surfaces. If O.D. of needle bearing surface is less than 0.864 in. (21.95 mm), replace the main shaft.
  - B. Inspect lip portion of oil seal and oil seal surface of main shaft for wear or damage.
  - C. Insert spline for clutch disk and check for excessive looseness and free sliding of clutch disk hub.

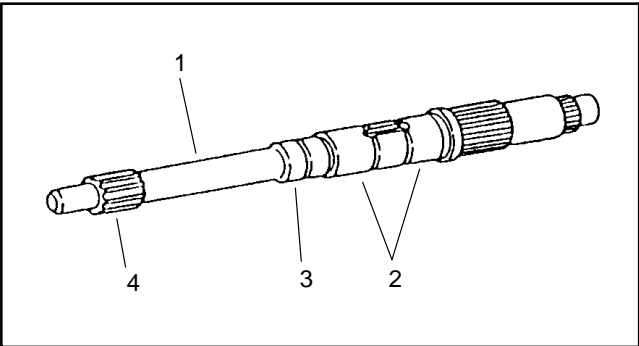

Figure 58

- |                           |                           |
|---------------------------|---------------------------|
| 1. Main shaft             | 3. Oil seal surface       |
| 2. Needle bearing surface | 4. Spline for clutch disc |

8. Inspect snap ring and shim(s) for damage. Replace all parts if any part is cracked or broken.

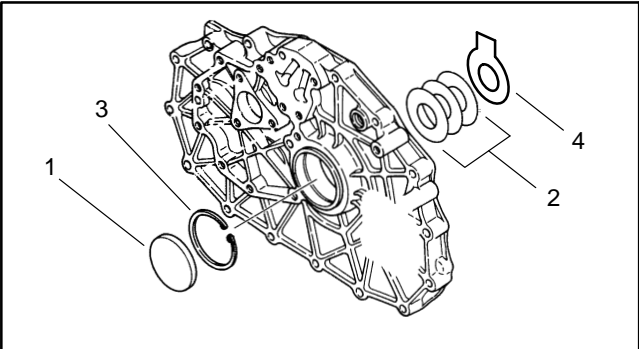

Figure 59

- |             |              |
|-------------|--------------|
| 1. Seal cap | 3. Snap ring |
| 2. Shims    | 4. Shim      |

9. Inspect center plate for cracks and damage. Replace center plate if the snap ring groove has more than 15% of its edges damaged due to nicks, rounding, cracks or dents.

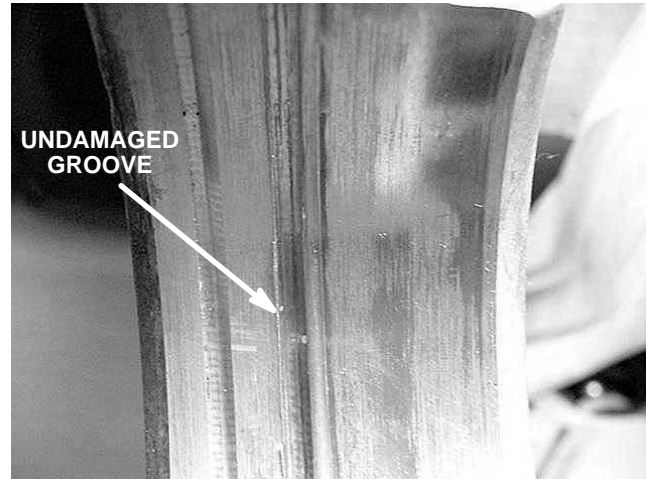

Figure 60

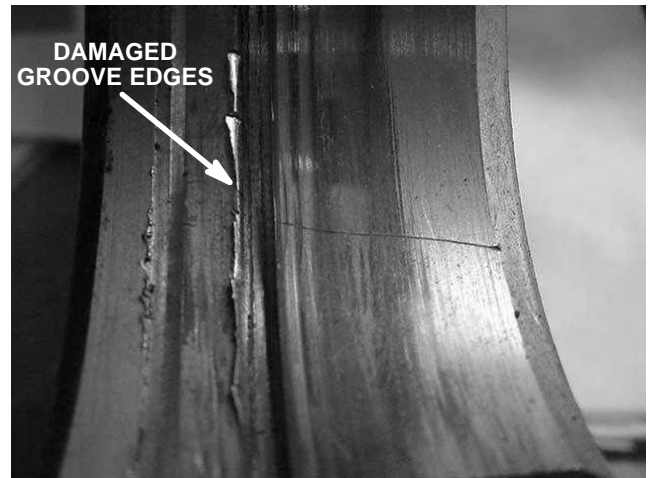

Figure 61

10. Inspect reduction shaft for wear or damage. If O.D. of outer needle bearing area is less than 0.864 in. (21.95 mm) or inner needle bearing area is less than 0.982 in. (24.95 mm), replace the reduction shaft.

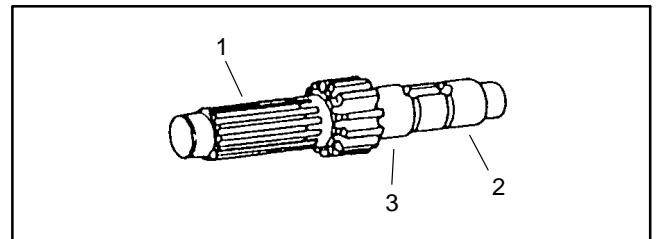

Figure 62

- 1. Reduction shaft
- 2. Outer bearing area
- 3. Inner bearing area

11. Inspect countershaft for wear or damage. If O.D. of inner portion is less than 1.100 in. (27.95 mm) or 71T gear portion is less than 1.179 in. (29.95 mm), replace the countershaft.

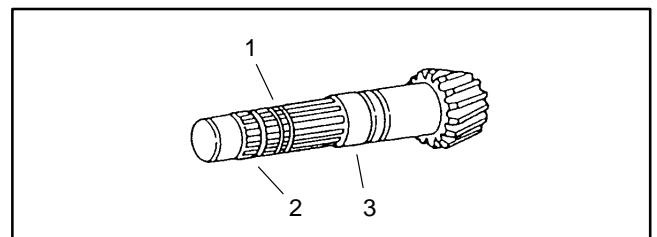

Figure 63

- 1. Countershaft
- 2. Inner portion
- 3. Gear portion

12. Inspect differential:

A. Inspect pinion shaft for excessive wear or damage. If O.D. is less than 0.707 in. (17.95 mm), replace the pinion shaft.

B. Measure thickness of pinion liners. If thickness is less than 0.035 in. (0.9 mm), replace the pinion liners.

C. Measure thickness of side gear liners. If thickness is less than 0.043 in. (1.1 mm), replace the side gear liners.

D. Inspect the gear contact condition between spiral bevel pinion and ring gear.

E. Inspect differential case for wear in side gears and pinion shaft mating area. Replace the case if machined surfaces are scored or if the pinion shaft fits loosely in the bore.

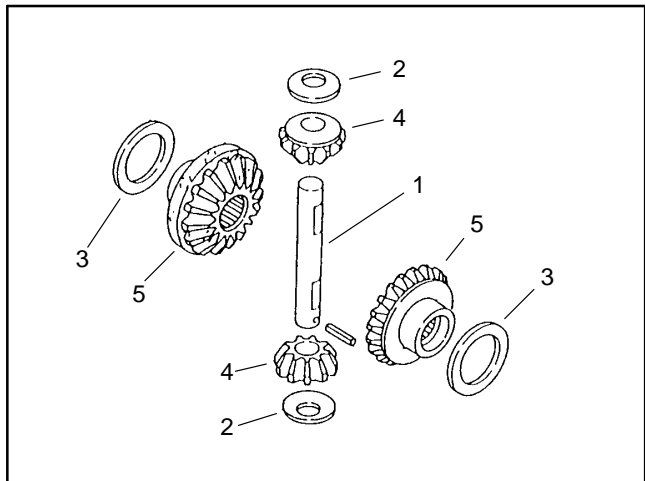

Figure 64

- |                        |                    |
|------------------------|--------------------|
| 1. Pinion shaft        | 4. Pinion gear (2) |
| 2. Pinion liner (2)    | 5. Side gear (2)   |
| 3. Side gear liner (2) |                    |



## Transaxle Assembly

1. Clean gasket material from all mating surfaces before reassembling. Make sure all parts are clean and free of dirt and dust.

**IMPORTANT: Be careful not to damage mating surfaces when removing gasket material.**

### 2. Assemble L.H. axle shaft:

- A. Install new oil seal into differential carrier.
- B. Use a press to install bearing onto L.H. axle shaft.
- C. Install washer and snap ring.
- D. Install L.H. axle shaft assembly into differential carrier.
- E. Install snap ring.
- F. Install new O-ring. Apply multi-purpose grease on O-ring before installing.

### 3. Assemble R.H. axle shaft:

- A. Install new oil seal into seal cover. Apply multi-purpose grease on O-ring before installing.
- B. Insert washer.
- C. Use a press to install bearing onto R.H. axle shaft.
- D. Install washer and snap ring.
- E. Install R.H. axle shaft assembly into seal cover.

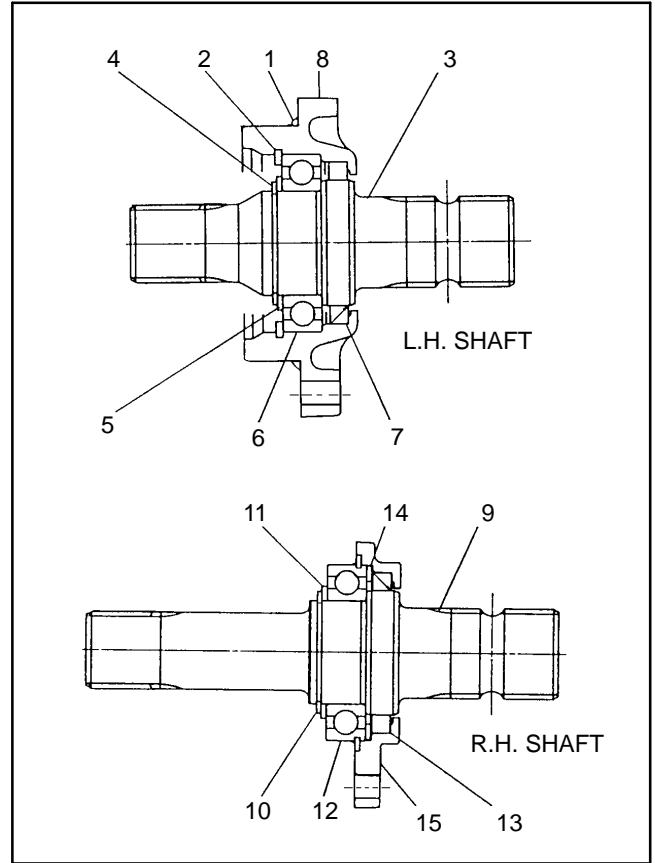

Figure 65

- |                             |                             |
|-----------------------------|-----------------------------|
| 1. O-ring                   | 9. R.H. axle shaft assembly |
| 2. Snap ring                | 10. Snap ring               |
| 3. L.H. axle shaft assembly | 11. Washer                  |
| 4. Snap ring                | 12. Bearing                 |
| 5. Washer                   | 13. Oil seal                |
| 6. Bearing                  | 14. Washer                  |
| 7. Oil seal                 | 15. Seal cover              |
| 8. Differential carrier     |                             |

### 4. Assemble differential fork shaft:

- A. Drive lock pins into fork shaft. Make sure lock pins are installed with slit facing the correct direction.
- B. Install fork, spring, washer and snap ring onto fork shaft using a press. Apply moly disulfide grease onto fork portion of fork shaft before installing.
- C. Install new O-ring. Apply multi-purpose grease on O-ring before installing.

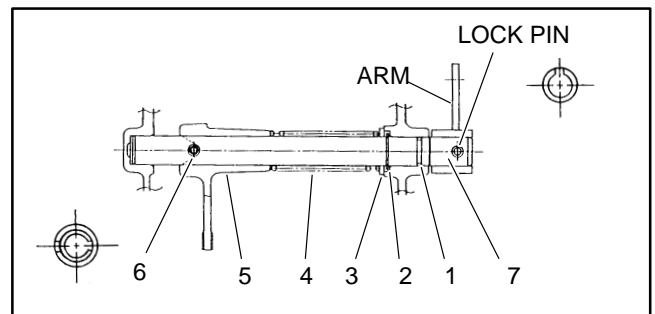

Figure 66

- |              |               |
|--------------|---------------|
| 1. O-ring    | 5. Fork       |
| 2. Snap ring | 6. Lock pin   |
| 3. Washer    | 7. Fork shaft |
| 4. Spring    |               |

5. Assemble differential gears:

A. Apply moly disulfide grease on pinion liners, holes of pinion gears, side gear liners and hubs of side gears.

B. Install side gear liners, side gears, pinion liners and pinion gears.

C. Rotate side gears until holes of pinion gears and liners align with holes of differential case.

D. Insert pinion shaft. Grease the shaft to aid assembly.

E. Assemble lock pin (Fig. 69). Drive the pin to the approximate center location of the pinion mate shaft. Pay attention to direction of slit in lock pin.

F. Check for smooth revolution of pinion gears and side gears.

G. Completely clean oil from threads in ring gear.

**NOTE:** Ring gear and countershaft are supplied in matched sets only.

H. Insert dowel pins onto ring gear.

I. Completely clean oil from threads of cap screws.

**NOTE:** It is recommended that whenever the ring gear screws are removed that they be replaced with new screws.

J. Apply Loctite to threads of cap screws.

K. Clean oil from contact surface of differential case and ring gear.

L. Drive ring gear onto differential case.

M. Install and tighten cap screws to a torque from **18.5 to 22 ft-lb (24.5 to 29.5 N-m)**.

N. Use a press to install bearing onto differential case.

O. Install slider. Put moly disulfide grease onto sliding area of differential case before installing.

P. Use a press to install bearing.

Q. Install snap ring.

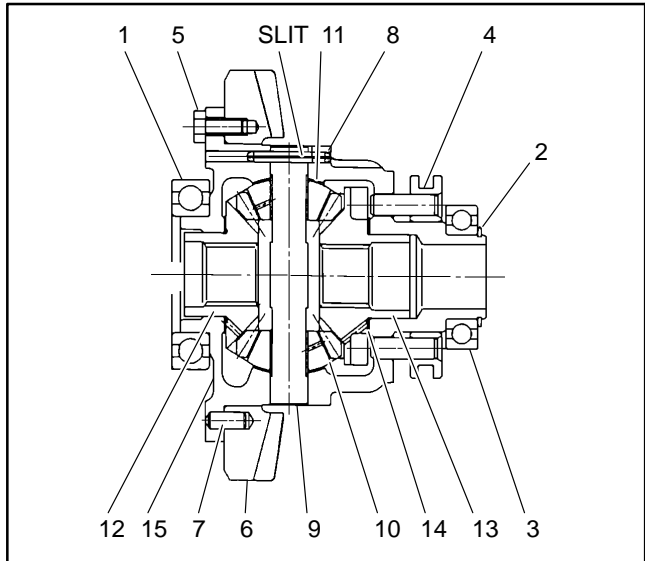

Figure 67

- |                  |                    |
|------------------|--------------------|
| 1. Bearing       | 8. Lock pin        |
| 2. Snap ring     | 9. Pinion shaft    |
| 3. Bearing       | 10. Pinion (2)     |
| 4. Slider        | 11. Liner (2)      |
| 5. Screws        | 12. L.H. side gear |
| 6. Ring gear     | 13. R.H. Side gear |
| 7. Dowel pin (2) | 14. Liner (2)      |

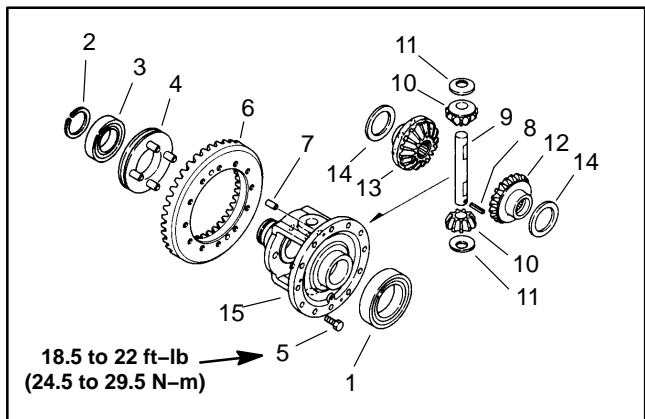

Figure 68

- |                  |                    |
|------------------|--------------------|
| 1. Bearing       | 8. Lock pin        |
| 2. Snap ring     | 9. Pinion shaft    |
| 3. Bearing       | 10. Pinion (2)     |
| 4. Slider        | 11. Liner (2)      |
| 5. Screws        | 12. L.H. side gear |
| 6. Ring gear     | 13. R.H. Side gear |
| 7. Dowel pin (2) | 14. Liner (2)      |



Figure 69

6. Assemble Hi-Lo fork shaft:

- A. Install E-ring onto fork shaft.
- B. Insert spring and steel ball into fork.
- C. Insert fork shaft into fork. Put moly disulfide grease onto the shaft before installing.

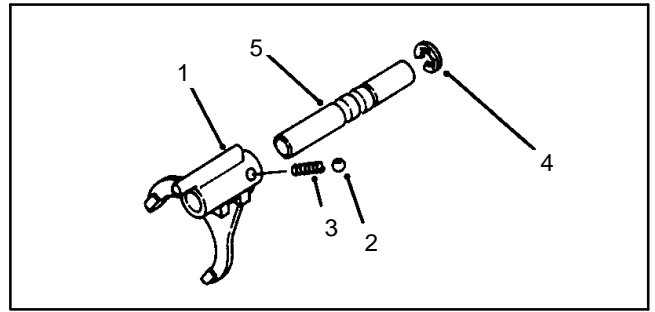

Figure 70

- 1. Shift fork
- 2. Steel ball
- 3. Spring
- 4. E-ring
- 5. Hi-Lo fork shaft

7. Assemble R-1 and 2-3 fork shaft:

- A. Insert R-1 fork shaft into R-1 fork.
- B. Drive lock pin into fork and fork shaft. Pay attention to direction of slit in lock pin.
- C. Insert 2-3 fork shaft into 2-3 fork.
- D. Drive lock pin into fork and fork shaft. Pay attention to direction of slit in lock pin.

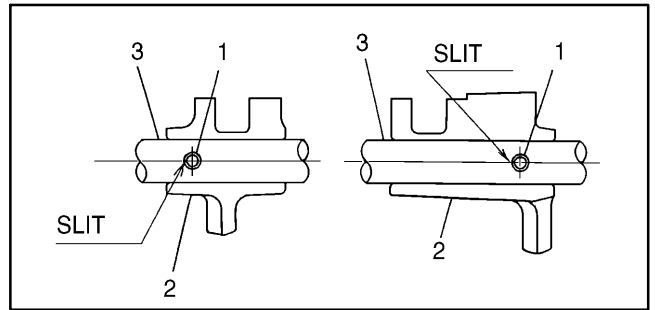

Figure 71

- 1. Lock pin
- 2. Shift fork
- 3. Fork shaft

8. Assemble countershaft:

A. Use a press to install new bearings (item 15) onto countershaft.

B. Install collar and snap ring.

C. Install washer and gear. Apply moly disulfide grease into bushing of countershaft gear before installing. Oil groove on washer must face the gear.

D. Install collar–spline and snap ring.

E. Install shifter onto collar–spline.

F. Install snap ring, washer and inner race. Oil groove on washer must face the gear.

G. Install gear.

H. Install washer and snap ring. Oil groove on washer must face the gear.

I. Install washer and a new bearing (item 1) using a press.

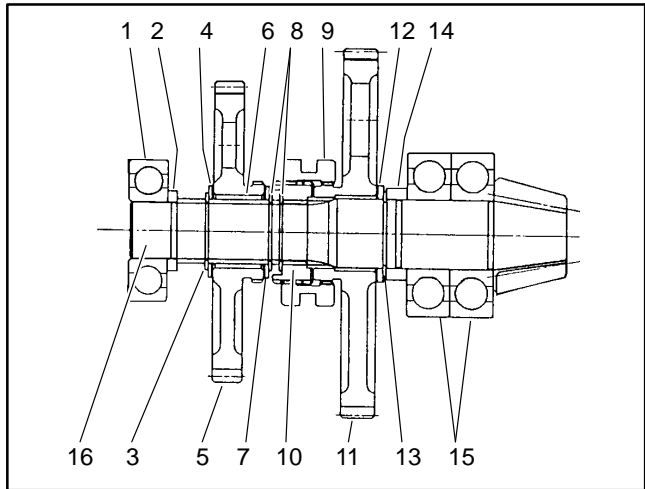

Figure 72

- |                  |                   |
|------------------|-------------------|
| 1. Bearing       | 9. Hi-Lo shifter  |
| 2. Thrust washer | 10. Collar spline |
| 3. Snap ring     | 11. Gear          |
| 4. Thrust washer | 12. Washer        |
| 5. Gear          | 13. Snap ring     |
| 6. Inner race    | 14. Collar        |
| 7. Thrust washer | 15. Bearing (2)   |
| 8. Snap ring (2) | 16. Countershaft  |

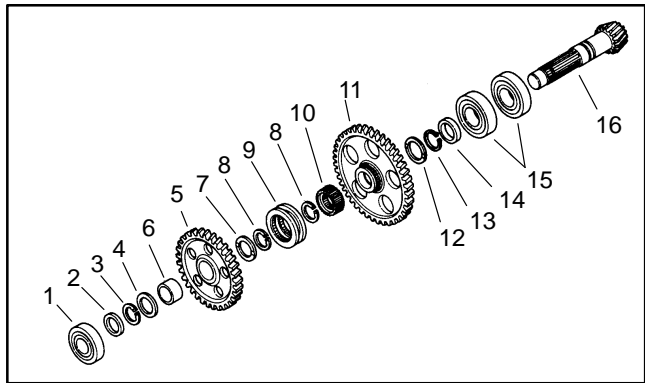

Figure 73

- |                  |                   |
|------------------|-------------------|
| 1. Bearing       | 9. Hi-Lo shifter  |
| 2. Thrust washer | 10. Collar spline |
| 3. Snap ring     | 11. Gear          |
| 4. Thrust washer | 12. Washer        |
| 5. Gear          | 13. Snap ring     |
| 6. Inner race    | 14. Collar        |
| 7. Thrust washer | 15. Bearing (2)   |
| 8. Snap ring (2) | 16. Countershaft  |

9. Assemble synchro hub:

A. Install keys into grooves of hub.

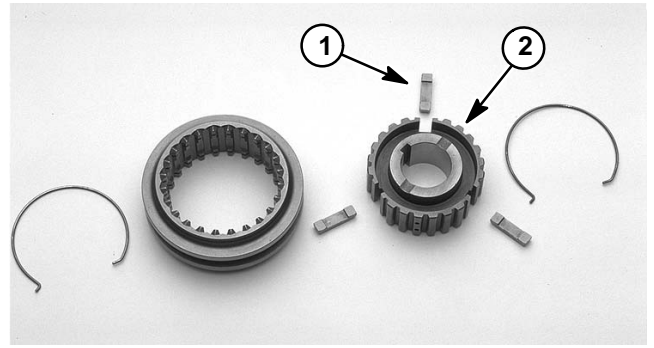

Figure 74

1. Key (3)

2. Hub

B. Install shifter onto hub.

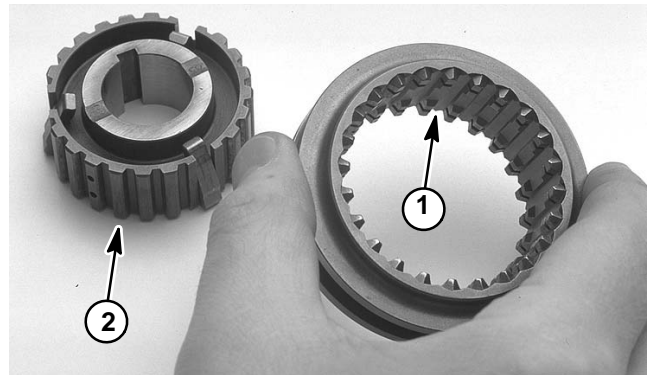

Figure 75

1. Shifter

2. Hub

C. Insert springs into hub. Pay attention to direction of spring.

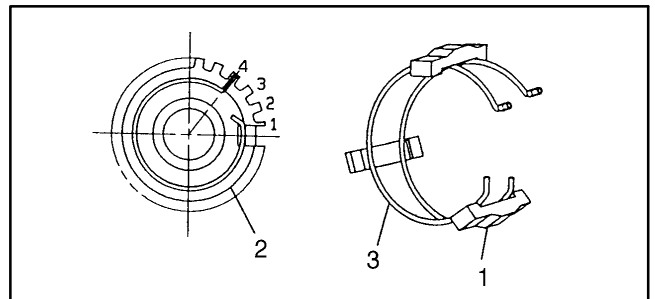

Figure 76

1. Key (3)  
2. Hub

3. Spring (2)



Figure 77

10. Assemble reduction shaft:

A. Install thrust washer (item 17), needle bearings and gear onto reduction shaft. Apply moly disulfide grease to washer and needle bearings before installing. Oil groove on washer must face the gear.

B. Install synchro ring onto gear. Apply clean Dex-ron III transmission oil on cone face of gear before installing synchro ring.

C. Insert key onto reduction shaft.

D. Install synchro hub sub-assembly.

E. Install snap ring.

F. Install spacer onto gear.

G. Insert needle bearings into gear.

H. Install washer. Oil groove on washer must face the gear.

I. Use a press to install bearing.

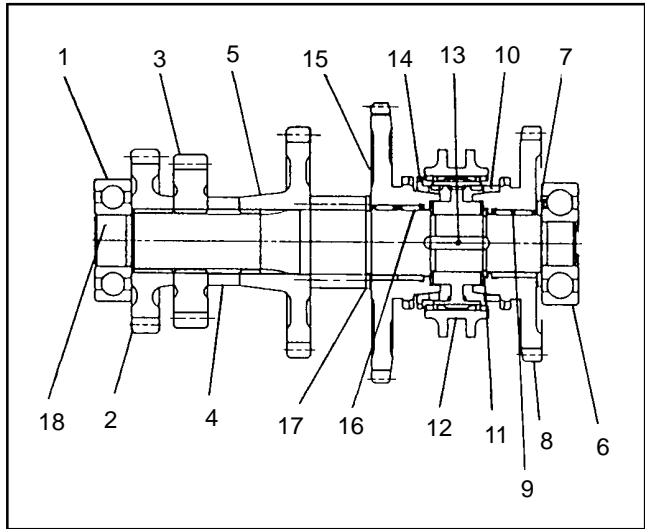

Figure 78

- |                   |                     |
|-------------------|---------------------|
| 1. Bearing        | 10. Spacer          |
| 2. Gear           | 11. Snap ring       |
| 3. Helical gear   | 12. Shifter         |
| 4. Collar         | 13. Key             |
| 5. Gear           | 14. Synchro ring    |
| 6. Bearing        | 15. Gear            |
| 7. Washer         | 16. Needle bearing  |
| 8. Gear           | 17. Thrust washer   |
| 9. Needle bearing | 18. Reduction shaft |

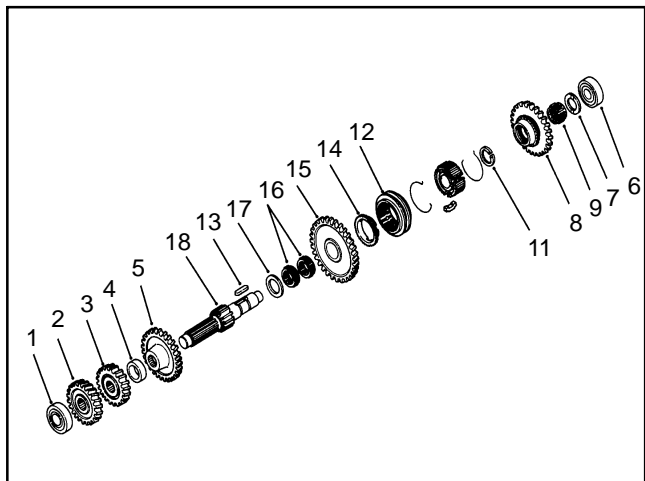

Figure 79

- |                   |                     |
|-------------------|---------------------|
| 1. Bearing        | 10. Spacer          |
| 2. Gear           | 11. Snap ring       |
| 3. Helical gear   | 12. Shifter         |
| 4. Collar         | 13. Key             |
| 5. Gear           | 14. Synchro ring    |
| 6. Bearing        | 15. Gear            |
| 7. Washer         | 16. Needle bearing  |
| 8. Gear           | 17. Thrust washer   |
| 9. Needle bearing | 18. Reduction shaft |

11. Assemble reverse shaft:

- A. Install gear onto reverse shaft.
- B. Use a press to install bearings.

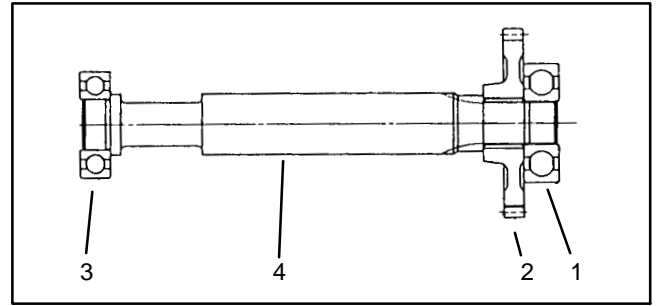

Figure 80

- |            |                  |
|------------|------------------|
| 1. Bearing | 3. Bearing       |
| 2. Gear    | 4. Reverse shaft |

12. Assemble main shaft:

- A. Install gears and snap ring.
- B. Install gear.
- C. Use a press to install bearing.
- D. Install washer and needle bearings onto main shaft. Apply moly disulfide grease onto washer and needle bearings before installing. Oil groove on washer must face the gear.
- E. Install gear and snap ring.
- F. Install synchro ring onto gear. Apply clean Dexron III transmission oil on cone face of gear before installing synchro ring.
- G. Insert key.
- H. Install synchro hub sub-assembly.
- I. Install snap ring.
- J. Install synchro ring onto gear. Apply clean Dexron III transmission oil to cone face of gear before installing synchro ring.
- K. Insert needle bearings into gear. Apply moly disulfide grease onto needle bearings before installing.
- L. Install gear with synchro ring onto main shaft.
- M. Install washer and snap ring. Apply moly disulfide grease to washer before installing. Oil groove on washer must face the gear.

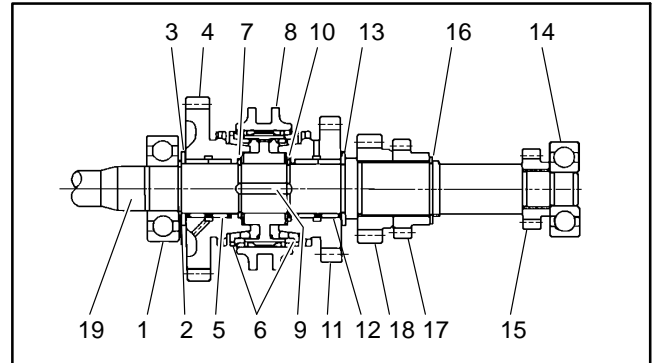

Figure 81

- |                       |                        |
|-----------------------|------------------------|
| 1. Bearing            | 11. Gear               |
| 2. Snap ring          | 12. Needle bearing (2) |
| 3. Washer             | 13. Washer             |
| 4. Gear               | 14. Bearing            |
| 5. Needle bearing (2) | 15. Gear               |
| 6. Synchro ring       | 16. Snap ring          |
| 7. Snap ring          | 17. Gear               |
| 8. Shifter            | 18. Gear               |
| 9. Key                | 19. Main shaft         |
| 10. Snap ring         |                        |

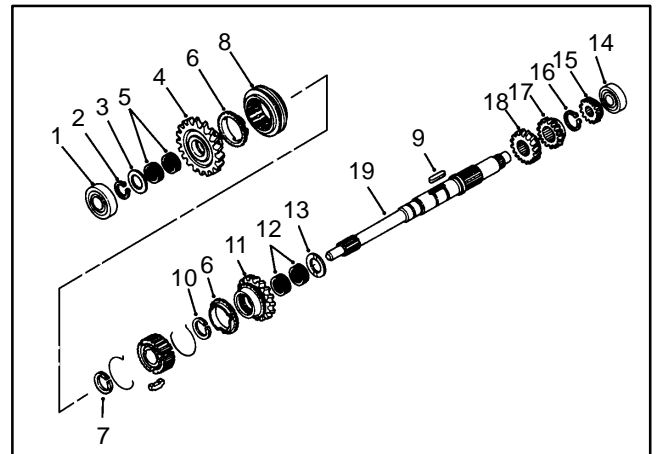

Figure 82

- |                       |                        |
|-----------------------|------------------------|
| 1. Bearing            | 11. Gear               |
| 2. Snap ring          | 12. Needle bearing (2) |
| 3. Washer             | 13. Washer             |
| 4. Gear               | 14. Bearing            |
| 5. Needle bearing (2) | 15. Gear               |
| 6. Synchro ring       | 16. Snap ring          |
| 7. Snap ring          | 17. Gear               |
| 8. Shifter            | 18. Gear               |
| 9. Key                | 19. Main shaft         |
| 10. Snap ring         |                        |

13. Assemble shift arms:

A. Install new oil seals into transaxle case. Apply multi-purpose grease on lips of oil seals before installing.

B. Install keeper plates and tighten flange head screws to a torque from **11 to 13 ft-lb (15 to 17 N-m)**.

C. Apply Loctite #680 (or equivalent) to threads and tapers of shift fork arms.

D. Install shift arms. Install shift arm assembly.

E. Install lock nuts. Tighten shift arm retaining lock nuts to a torque from **230 to 240 in-lb (26 to 27 N-m)**.

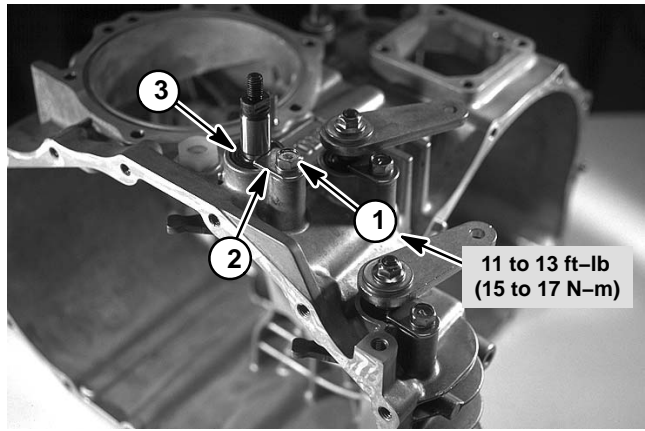

Figure 83

- |                          |                 |
|--------------------------|-----------------|
| 1. Flange head screw (3) | 3. Oil seal (3) |
| 2. Keeper plate (3)      |                 |

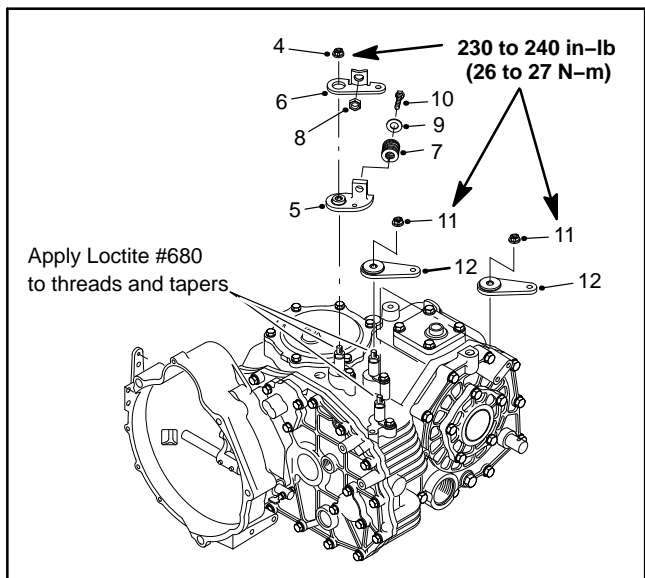

Figure 84

- |   |                   |
|---|-------------------|
| 4. Lock nut                                   | 9. Washer         |
| 5. 2 <sup>nd</sup> _3 <sup>rd</sup> shift arm | 10. Cap screw     |
| 6. Shift arm plate                            | 11. Lock nut      |
| 7. Spring                                     | 12. Shift arm (2) |
| 8. Lock nut                                   |                   |

14. Install oil cap with O-ring. Apply multi-purpose grease to O-ring.

15. If removed, install air breather. Use sealing tape on threads of air breather.

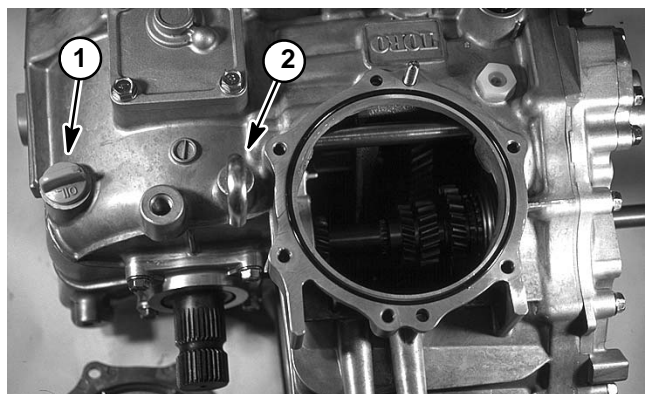

Figure 85

- |            |                 |
|------------|-----------------|
| 1. Oil cap | 2. Air breather |
|------------|-----------------|



16. Assemble reduction shaft and countershaft together with R-1 fork shaft and Hi-Lo fork shaft.

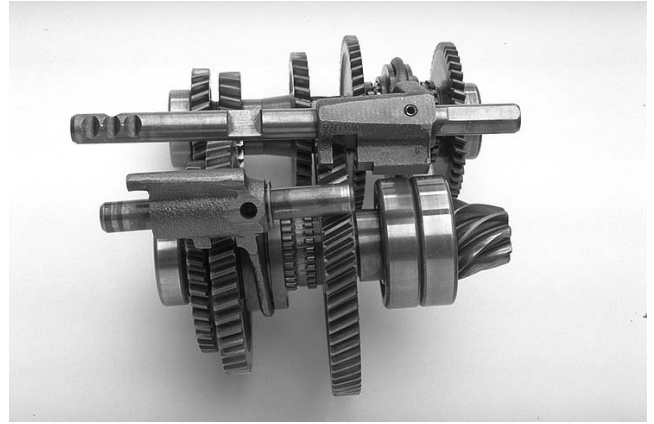

Figure 86

17. Insert reduction shaft and countershaft assembly into transaxle case. Insert heads of shift arms into grooves of forks when installing them.

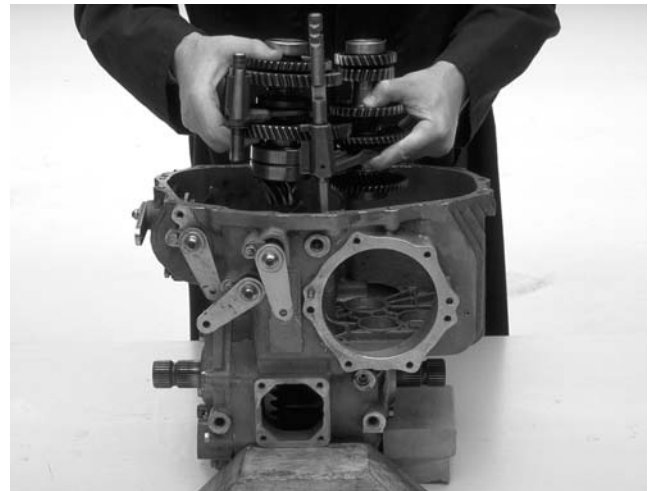

Figure 87

18. Assemble main shaft together with 2-3 fork shaft.

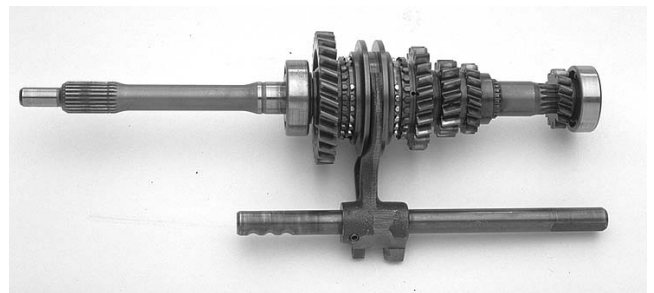

Figure 88

19. Insert main shaft and 2-3 fork shaft assembly into transaxle case. Insert head of shift arm into groove of fork while installing.

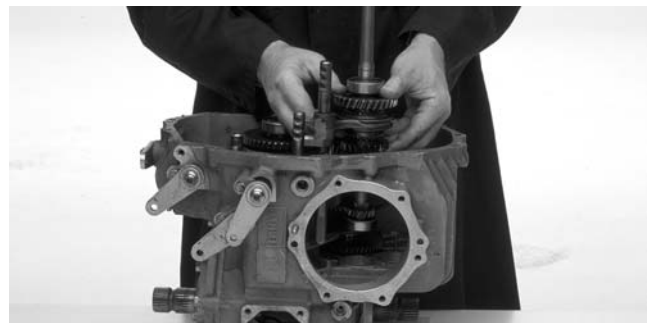

Figure 89

20. Install reverse shaft into transaxle case. Rotate main shaft and reverse shaft gears to mesh gears when installing.

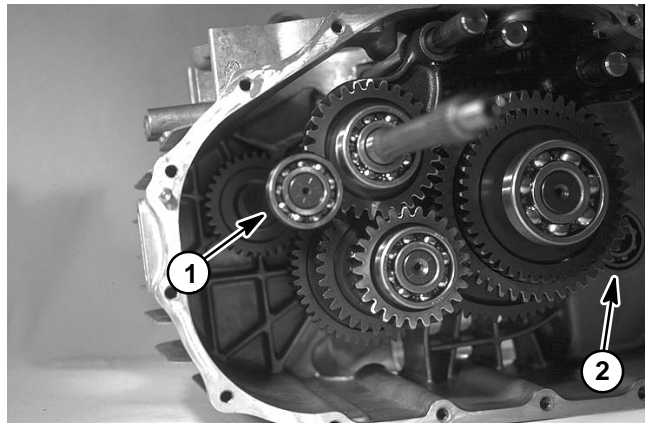

Figure 90

- 1. Reverse shaft
- 2. Bearing (gear case)

21. 4WD UNITS ONLY: Install bearing to gear case and center plate. Install front drive shaft and 41T gear to the gear case.

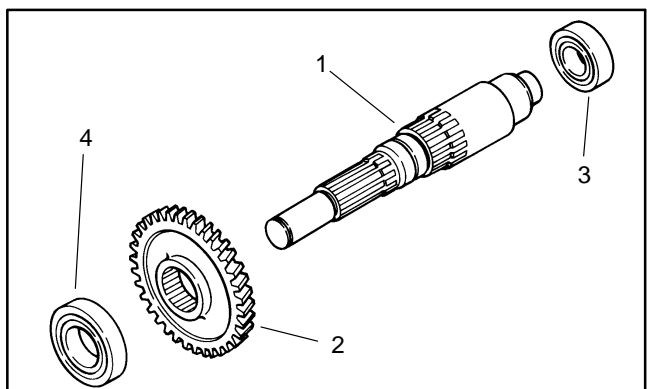

Figure 91

- 1. Front drive shaft
- 2. 41T gear
- 3. Bearing (gear case)
- 4. Bearing (center plate)

22. Install center plate:

- A. Insert dowel pins into transaxle case.
- B. Apply silicone sealant onto mating surface of center plate.
- C. Position center plate to transaxle.
- D. Install and tighten fifteen (15) flange head screws to a torque from **18.5 to 22 ft-lb (24.5 to 29.5 N-m)**.
- E. Apply multi-purpose grease onto lips of oil seal, then insert oil seal flush with face of housing.
- F. Apply moly disulfide grease to spline of main shaft for clutch disk hub.

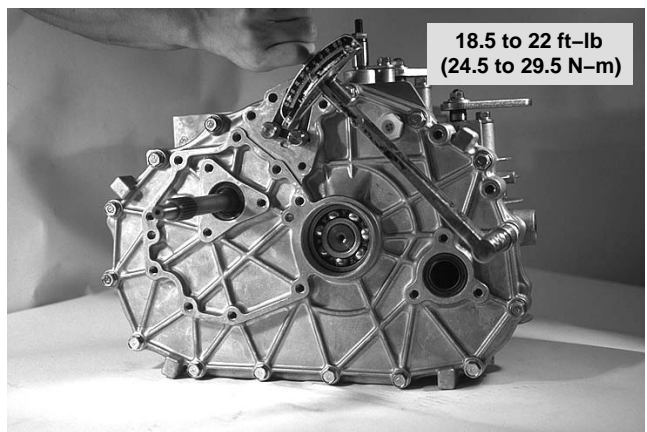

Figure 92

**NOTE:** The thickest shim of the shim set should be positioned against the snap ring.

23. Insert tabbed shim against the bearing. Insert shim set against the tabbed shim. Use thickest shims in set possible, that will permit installation of the snap ring.

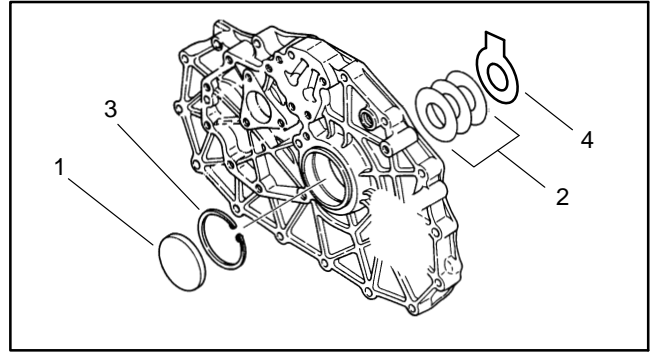

Figure 93

- |             |              |
|-------------|--------------|
| 1. Seal cap | 3. Snap ring |
| 2. Shims    | 4. Shim      |

24. Install snap ring into the groove of the bearing housing.

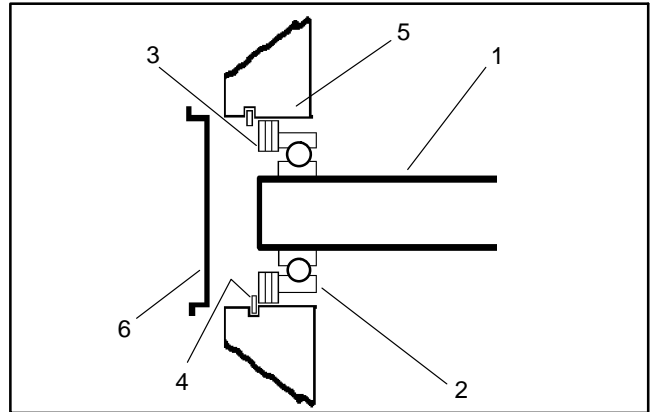

Figure 94

- |                 |                 |
|-----------------|-----------------|
| 1. Countershaft | 4. Snap ring    |
| 2. Bearing      | 5. Center plate |
| 3. Shims        | 6. Sealing cap  |



Figure 95

25. Measure countershaft end play. Rotate one of the axle shafts back and forth to take up all back lash. Rotating the shaft in one direction will pull the shaft and bearing away from the snap ring. Rotate axle shaft in this direction, then measure space between the snap ring and shim (set) with a feeler gauge. Make sure shim (set) is held against the bearing during the measurement. End play should be from 0.000 to 0.0039 in. (0.00 to 0.10 mm).

**IMPORTANT: If end play is too large, replace shim/ shim set with thicker shims to reduce end play.**



Figure 96

26. Insert sealing cap flush with face of housing. Make sure to not insert sealing cap too far. Pay attention to direction of sealing cap.

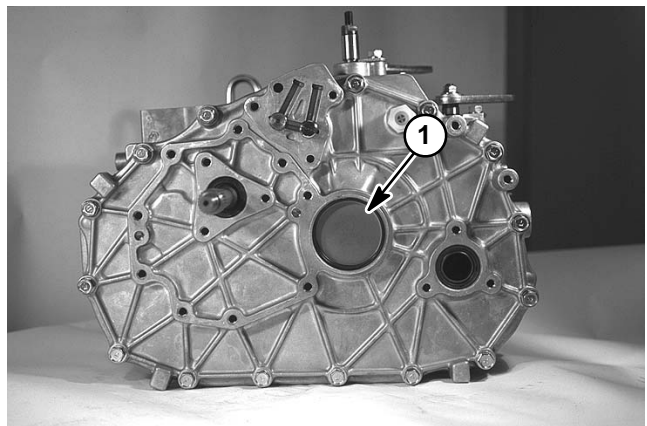

Figure 97  
1. Sealing cap

27. Install fork shaft case:

- A. Insert spindle between fork shafts.

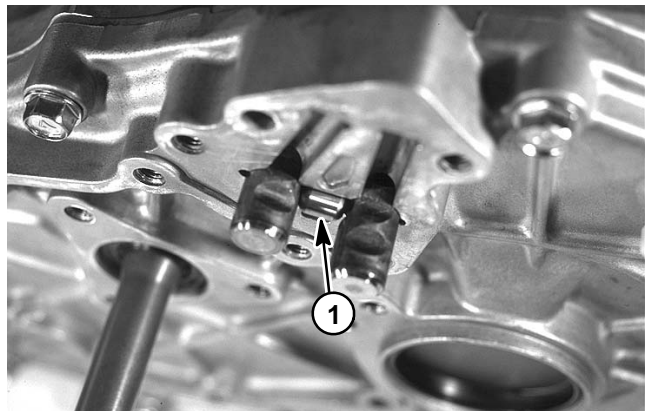

Figure 98  
1. Spindle

B. Insert steel balls and springs into the grooves.

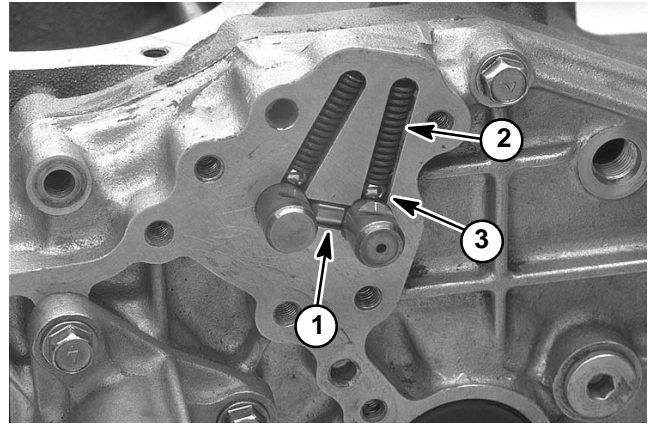

Figure 99

- 1. Spindle
- 2. Spring (2)
- 3. Ball (2)

C. Apply silicone sealant to mating surface of fork shaft case.

D. Install fork shaft case. Install and tighten flange head screws to a torque from **18.5 to 22 ft-lb (24.5 to 29.5 N-m)**.

E. Check operation of shifters and detent.

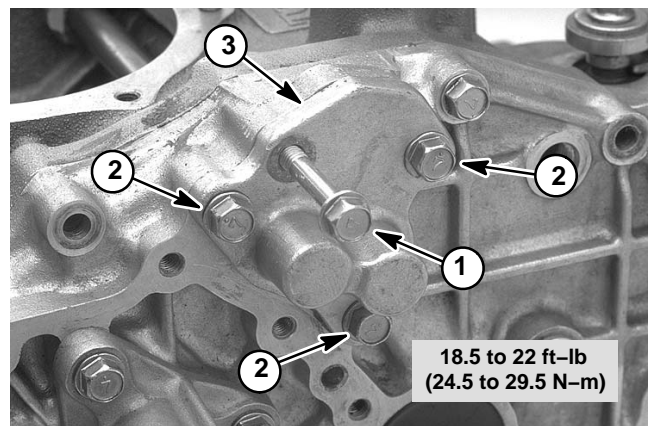

Figure 100

- 1. Flange head screw (1)
- 2. Flange head screw (3)
- 3. Fork shaft case

28. Insert a washer into housing of transaxle case. Apply moly disulfide grease to washer before installing.

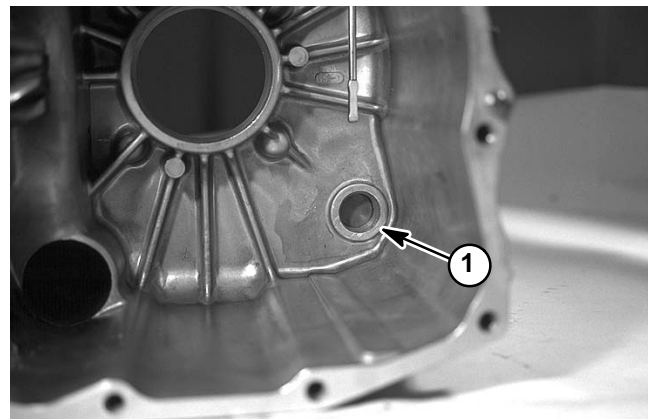

Figure 101

- 1. Washer

29. Install differential gear assembly together with fork shaft onto transaxle case.



Figure 102

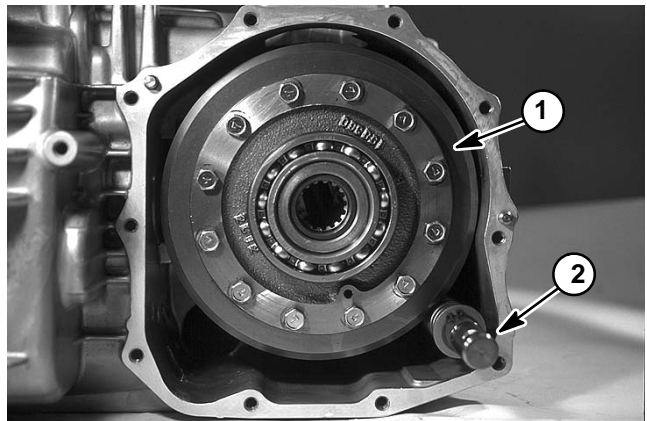

Figure 103

- 1. Differential gear assy.
- 2. Fork shaft

30. Install side cover:

- A. Insert dowel pins onto transaxle case.
- B. Apply silicone sealant onto mating surface of side cover.
- C. Install side cover and secure with ten (10) flange head screws. Torque screws from **18.5 to 22 ft-lb (24.5 to 29.5 N-m)**.



Figure 104

31. Install R.H. axle shaft assembly:

A. Apply silicone sealant onto mating surface of seal cover.

B. Install axle shaft assembly and secure with four (4) flange head screws. Torque screws from **18.5 to 22 ft-lb (24.5 to 29.5 N-m)**.

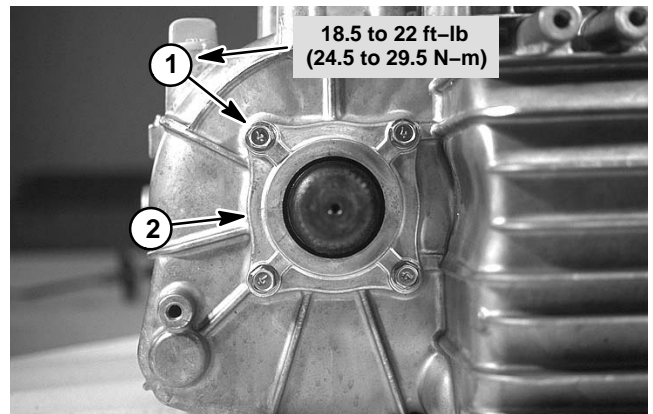

Figure 105

1. Flange head screw (4)      2. Axle shaft assembly

32. Install L.H. axle shaft assembly:

A. Thoroughly clean mating surface of differential carrier and side cover.

B. Insert selected shims into housing of side cover.

**NOTE:** The thickest shim should be installed against the bearing.

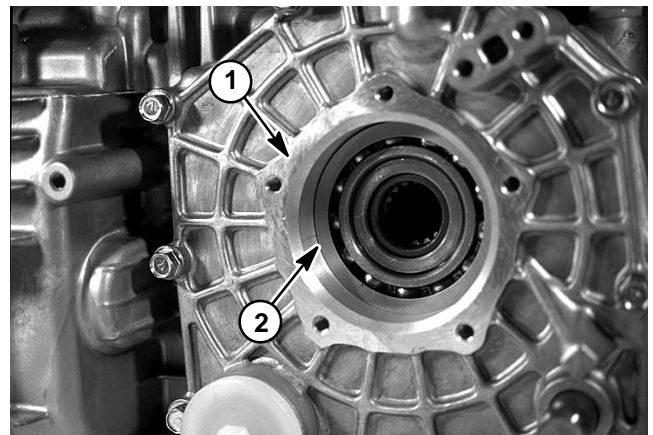

Figure 106

1. Mating surface      2. Shim

C. Install axle shaft assembly and secure with flange head screws. Torque screws from **18.5 to 22 ft-lb (24.5 to 29.5 N-m)**.

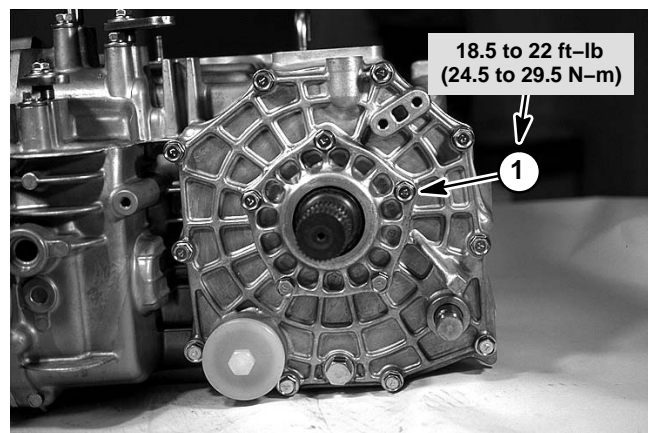

Figure 107

1. Flange head screw (5)

33. Measure backlash of ring gear through window on transaxle case. Using a dial indicator, check ring gear backlash in three equally spaced points. Backlash should be 0.0031 to 0.0071 in. (0.08 to 0.18 mm) and must not vary more than 0.0019 in. (0.05 mm) at the points checked. If backlash is not in this range, replace shim set in end of differential carrier:

A. If less than target range, decrease total thickness of shim set until correct backlash is achieved.

B. If exceeds the target range, increase total thickness of shim set until correct backlash is achieved.

**NOTE:** The thickest shim should be installed against the bearing.

34. Install differential lock arm onto fork shaft. Insert lock pin into fork shaft and arm. Pay attention to direction of slit in lock pin.



Figure 108

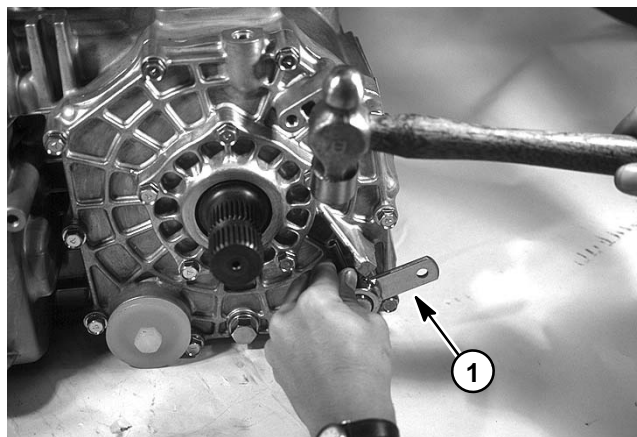

Figure 109

1. Differential lock arm

35. Apply silicone sealant to mating surface of upper cover. Pay attention to direction of cover and install. Secure with flange head screws. Torque screws from 18.5 to 22 ft-lb (24.5 to 29.5 N-m).

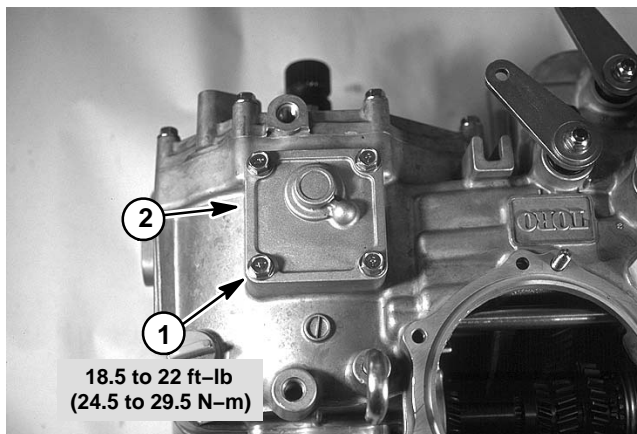

Figure 110

1. Flange head screw (4)      2. Upper cover



36. Apply multi-purpose grease to O-ring and insert O-ring into groove of transaxle case. Install cover and secure with nut, lockwasher and cap screws. Torque fasteners from **11 to 13 ft-lb (15 to 17 N-m)**.

**NOTE:** If equipped with optional PTO, install PTO assembly after the transaxle has been installed in vehicle. Plug transaxle opening to prevent debris entry into transaxle.

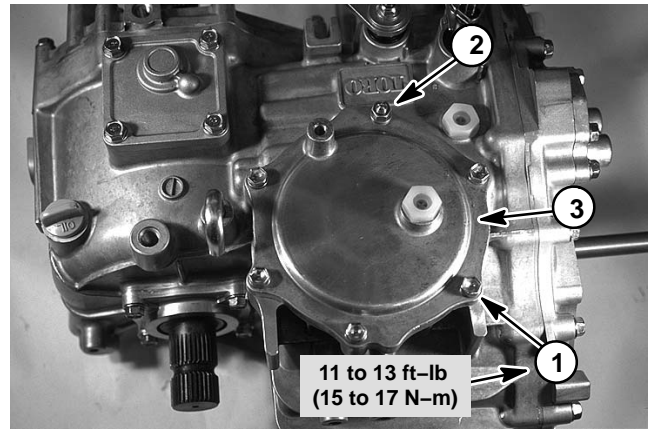

Figure 111

- 1. Cap screw (5)
- 2. Nut
- 3. PTO cover

37. Install bell housing and secure with flange head screws. Torque screws from **18.5 to 22 ft-lb (24.5 to 29.5 N-m)**.

38. Install extension spring.

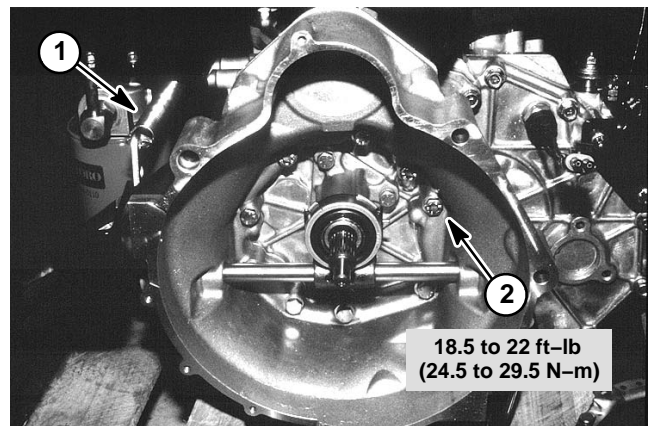

Figure 112

- 1. Extension
- 2. Flange hd screw (9)

## Power Take-Off (PTO) Service (If Equipped)

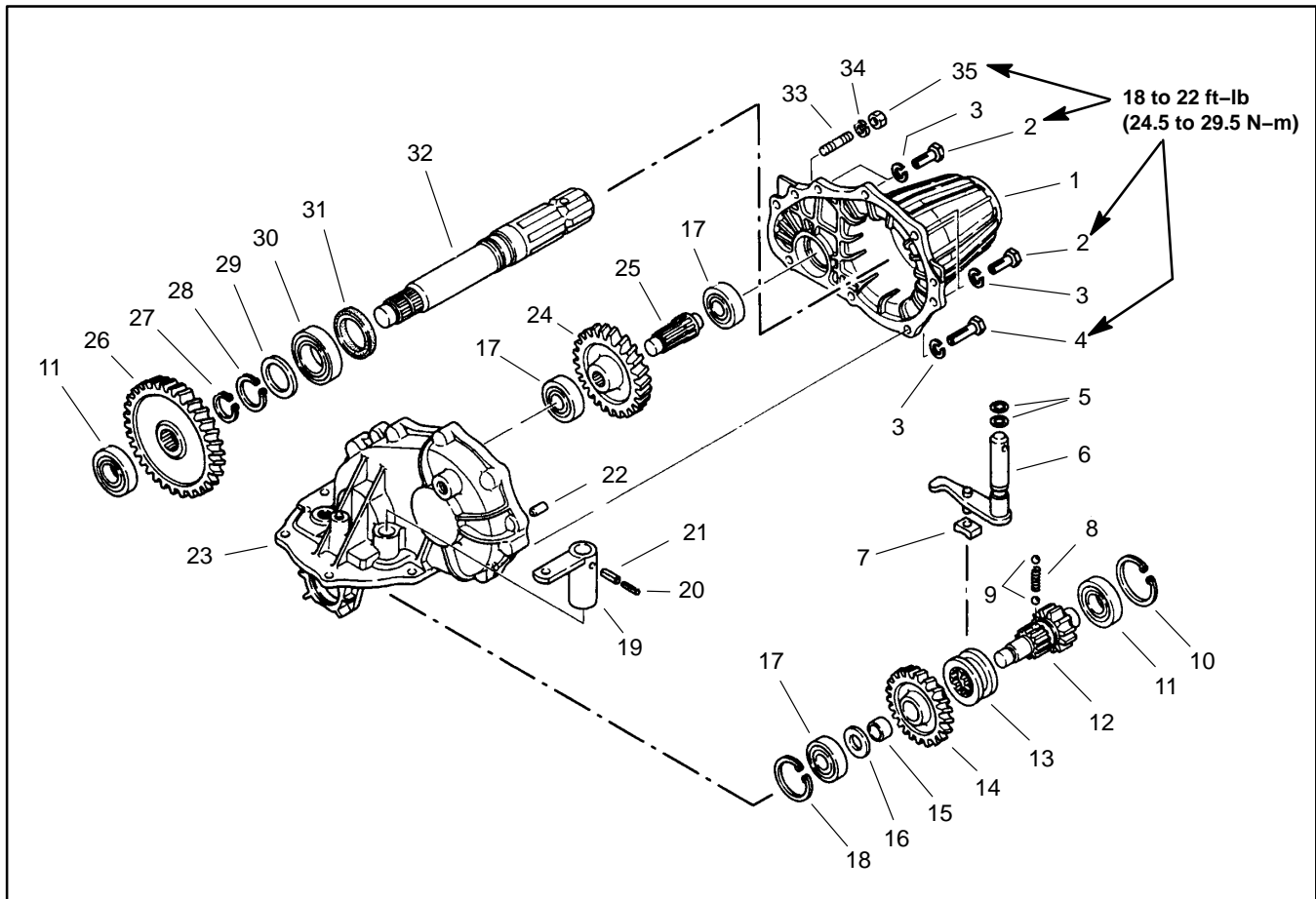

Figure 113

- |                    |                       |                        |
|--------------------|-----------------------|------------------------|
| 1. PTO cover       | 13. Shift collar      | 25. Intermediate shaft |
| 2. Cap screw (4)   | 14. Gear (29T)        | 26. Gear (37T)         |
| 3. Lock washer (7) | 15. Bushing           | 27. Retaining ring     |
| 4. Cap screw (3)   | 16. Thrust washer     | 28. Retaining ring     |
| 5. O-ring          | 17. Bearing           | 29. Thrust washer      |
| 6. Shift arm       | 18. Retaining ring    | 30. Bearing            |
| 7. Shifter block   | 19. Shift lever       | 31. Oil seal           |
| 8. Spring          | 20. Spring pin        | 32. Output shaft       |
| 9. Ball            | 21. Spring pin        | 33. Stud               |
| 10. Retaining ring | 22. Alignment pin (2) | 34. Lock washer        |
| 11. Bearing        | 23. PTO housing       | 35. Hex nut            |
| 12. Input shaft    | 24. Gear (27T)        |                        |

### Disassembly

**NOTE:** Item numbers in figures are shown in order of disassembly; for example, remove item 1 first, then item 2, etc. Assemble in reverse order; for example, install item 1 last.

1. Put vehicle on a level surface. Stop the engine and remove key from ignition switch. Remove the bed or other attachment(s). Allow transaxle and engine to cool.

2. Remove PTO from top of transaxle (see PTO Removal and Installation in this chapter).

3. Thoroughly clean outside surface of PTO case.

4. Loosen and remove cap screws and hex nut that secure PTO cover to housing. Note location and length of cap screws.

5. Separate PTO cover from PTO housing.

6. Remove PTO output shaft assembly from PTO housing. Remove oil seal from PTO cover.

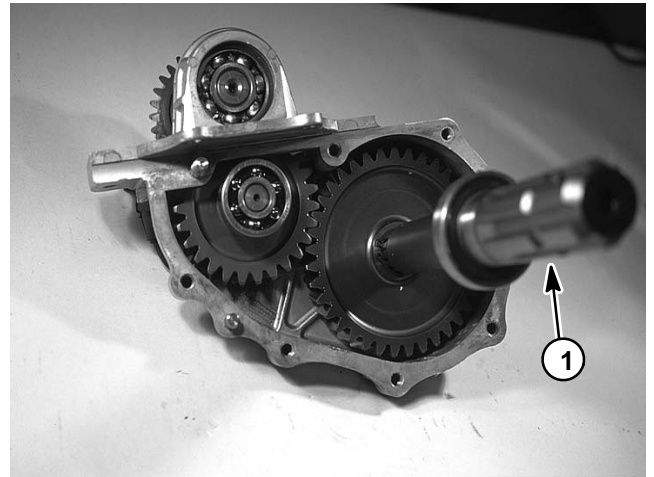

Figure 114

1. Output shaft assembly

7. Remove intermediate shaft assembly from PTO housing. Remove intermediate gear. Remove bearing from housing if necessary.

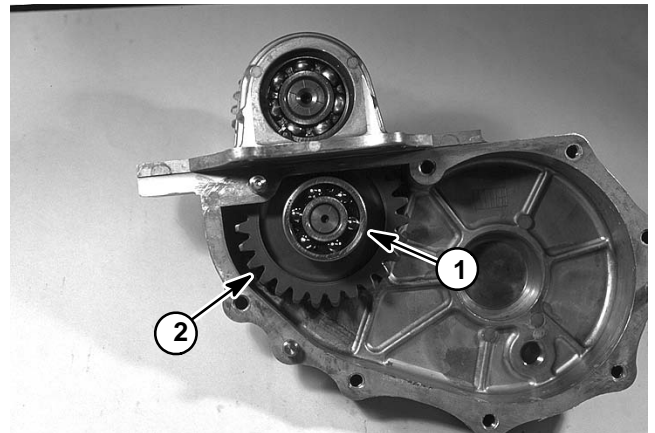

Figure 115

1. Intermediate shaft assy. 2. Intermediate gear

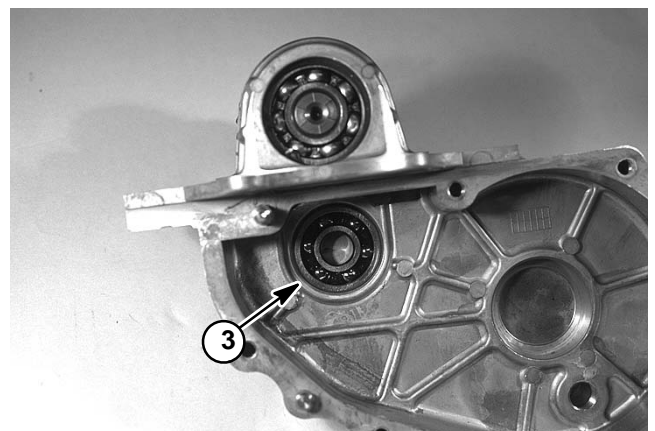

Figure 116

3. Bearing

8. Remove PTO input shaft from PTO housing:

- A. Shift PTO to "ON" position.
- B. Remove retaining rings from PTO housing.
- C. Slide input shaft assembly toward PTO shaft.
- D. Remove bearing (item 4).
- E. Slide input shaft away from PTO shaft.
- F. Remove bearing.
- G. Remove thrust washer and gear by sliding input shaft toward PTO shaft.
- H. Release shift arm from shifter block.
- I. Remove input shaft assembly.

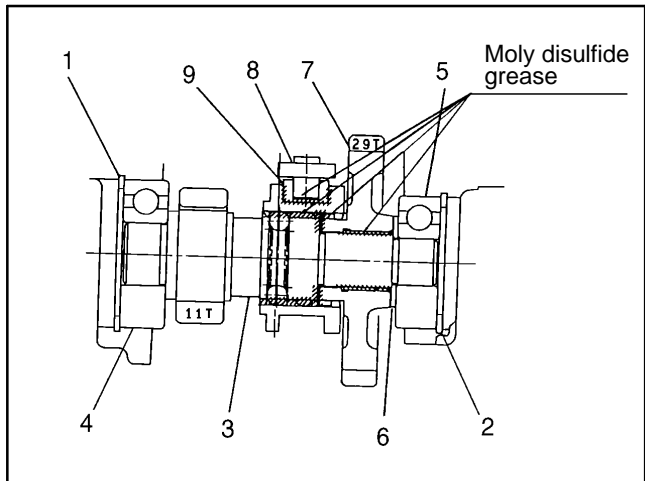

Figure 117

- |                         |                  |
|-------------------------|------------------|
| 1. Retaining ring       | 6. Thrust washer |
| 2. Retaining ring       | 7. Gear          |
| 3. Input shaft assembly | 8. Shift arm     |
| 4. Bearing              | 9. Shifter block |
| 5. Bearing              |                  |

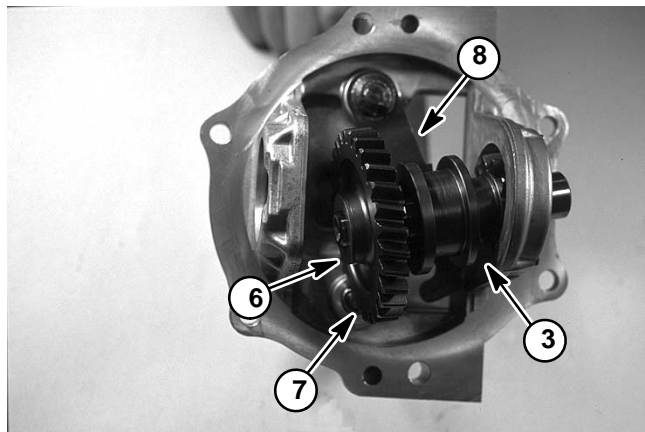

Figure 118

- |                         |              |
|-------------------------|--------------|
| 3. Input shaft assembly | 7. Gear      |
| 6. Thrust washer        | 8. Shift arm |

9. Disassemble PTO input shaft:

- A. Remove shift collar.
- B. Remove steel balls and spring.

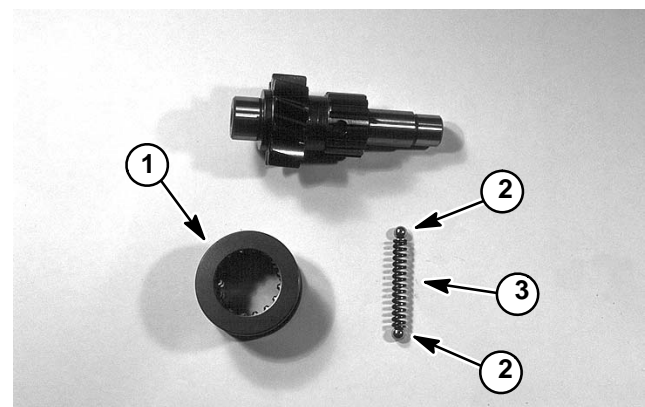

Figure 119

- |                   |           |
|-------------------|-----------|
| 1. Shift collar   | 3. Spring |
| 2. Steel ball (2) |           |

10. Disassemble PTO intermediate shaft:

- A. Use a bearing puller to remove bearing if necessary.

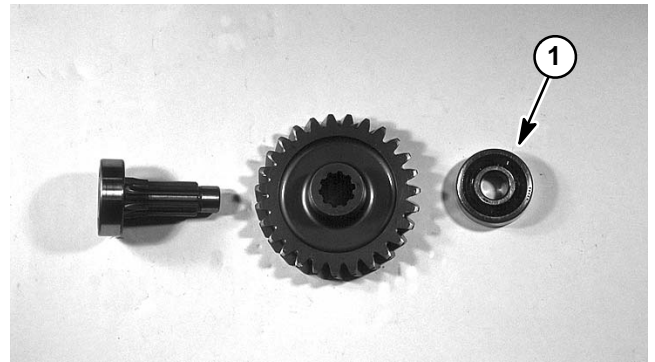

Figure 120  
1. Bearing

11. Disassemble PTO output shaft:

- A. Use a bearing puller to remove bearing.
- B. Remove gear and retaining ring.
- C. Remove retaining ring and thrust washer.
- D. Use a bearing puller to remove bearing if necessary.

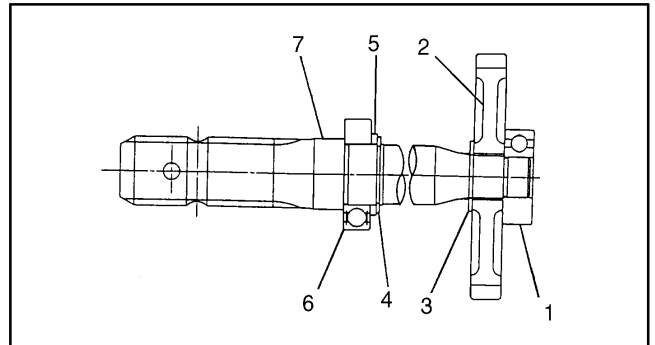

Figure 121

- |                   |                  |
|-------------------|------------------|
| 1. Bearing        | 5. Thrust washer |
| 2. Gear           | 6. Bearing       |
| 3. Retaining ring | 7. Output shaft  |
| 4. Retaining ring |                  |

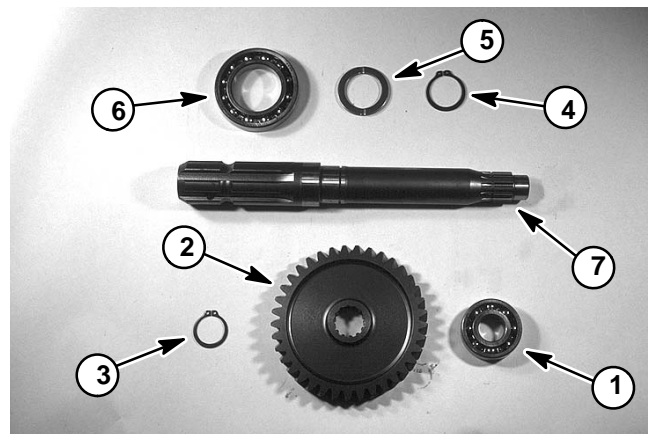

Figure 122

- |                   |                  |
|-------------------|------------------|
| 1. Bearing        | 5. Thrust washer |
| 2. Gear           | 6. Bearing       |
| 3. Retaining ring | 7. Output shaft  |
| 4. Retaining ring |                  |

12. Disassemble shift arm:

- A. Remove lock pins from shift arm.
- B. Remove O-rings.

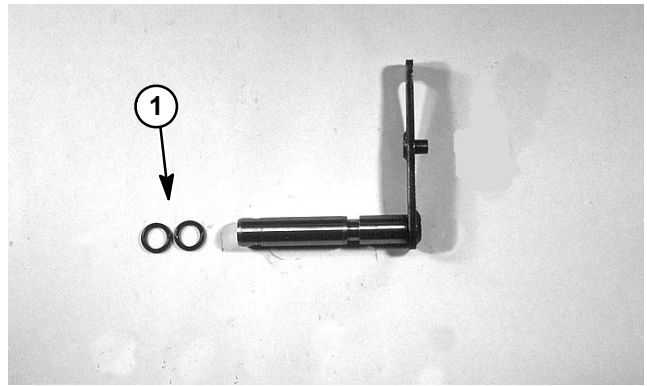

Figure 123

- 1. O-ring (2)

## Inspection

1. Thoroughly clean and dry all parts.
2. Use emery cloth to remove nicks and burrs from all parts.
3. Measure clearance between groove on shift collar and shifter block. Replace shifter block if clearance exceeds 0.039 in. (1.0 mm).

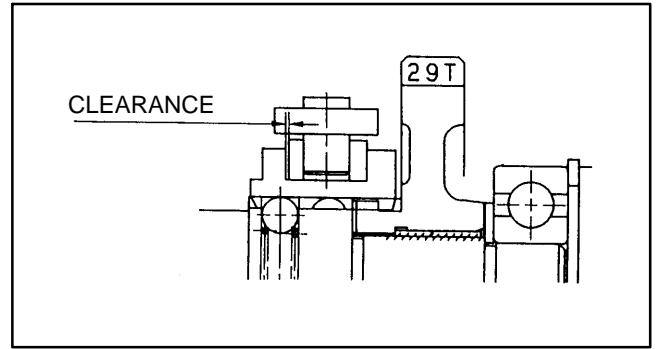

Figure 124

4. Measure I.D. of input shaft bushing. Replace bushing if I.D. exceeds 0.673 in. (17.10 mm).

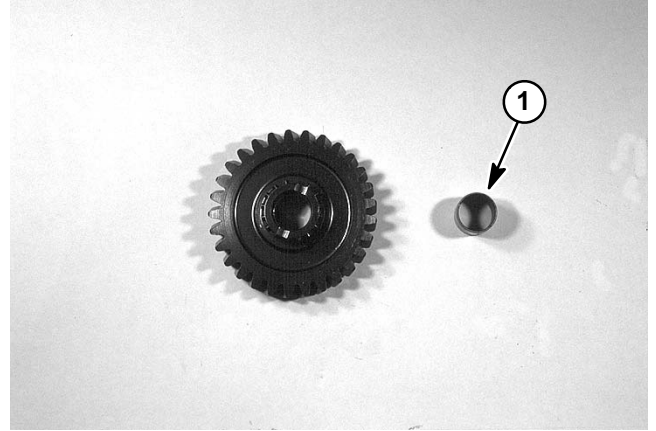

Figure 125

### 1. Input shaft bushing

5. Measure O.D. of bushing area on input shaft. Replace shaft if O.D. is less than 0.667 in. (16.95 mm). Inspect surface of bushing area for scoring or damage.

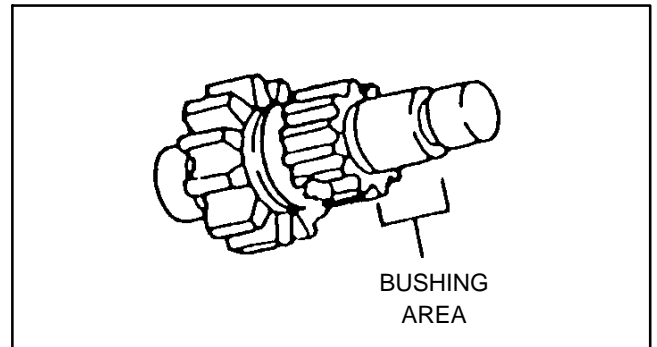

Figure 126

6. Inspect surface of oil seal area on output shaft for wear or damage.

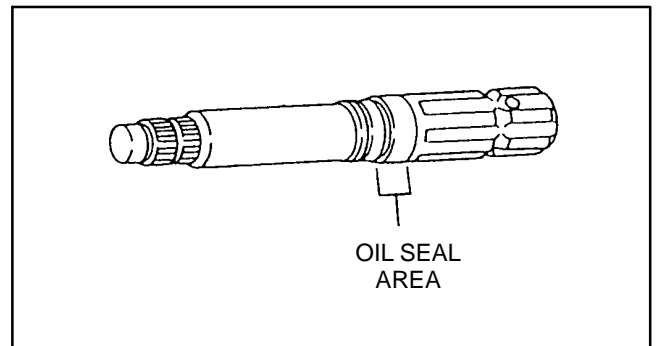

Figure 127

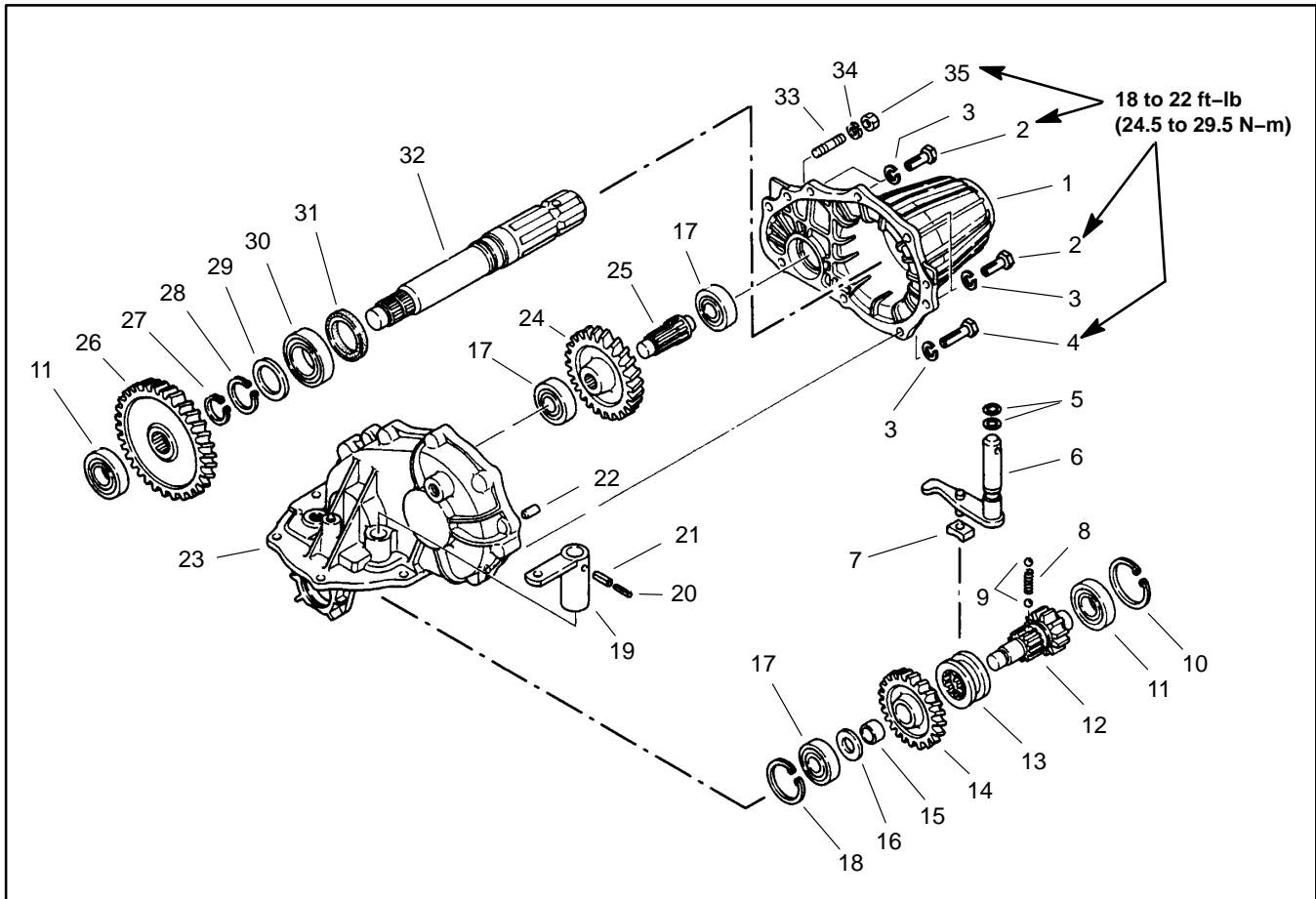

Figure 128

- |                    |                       |                        |
|--------------------|-----------------------|------------------------|
| 1. PTO cover       | 13. Shift collar      | 25. Intermediate shaft |
| 2. Cap screw (4)   | 14. Gear (29T)        | 26. Gear (37T)         |
| 3. Lock washer (7) | 15. Bushing           | 27. Retaining ring     |
| 4. Cap screw (3)   | 16. Thrust washer     | 28. Retaining ring     |
| 5. O-ring          | 17. Bearing           | 29. Thrust washer      |
| 6. Shift arm       | 18. Retaining ring    | 30. Bearing            |
| 7. Shifter block   | 19. Shift lever       | 31. Oil seal           |
| 8. Spring          | 20. Spring pin        | 32. Output shaft       |
| 9. Ball            | 21. Spring pin        | 33. Stud               |
| 10. Retaining ring | 22. Alignment pin (2) | 34. Lock washer        |
| 11. Bearing        | 23. PTO housing       | 35. Hex nut            |
| 12. Input shaft    | 24. Gear (27T)        |                        |

### Assembly

1. Clean gasket material from mating surfaces of housing and cover.

**IMPORTANT: Be careful not to damage mating surfaces when removing gasket material.**

2. Make sure all parts are free of dirt and dust.



3. Assemble shift arm:

- A. Apply moly disulfide grease to new O-rings and install onto shift arm.
- B. Apply moly disulfide grease to arm pin and shaft.
- C. Install shift arm into PTO housing.
- D. Install shift lever onto shift arm.
- E. Drive spring pins into shift lever and shift arm. Pay attention to direction of slit in spring pins.

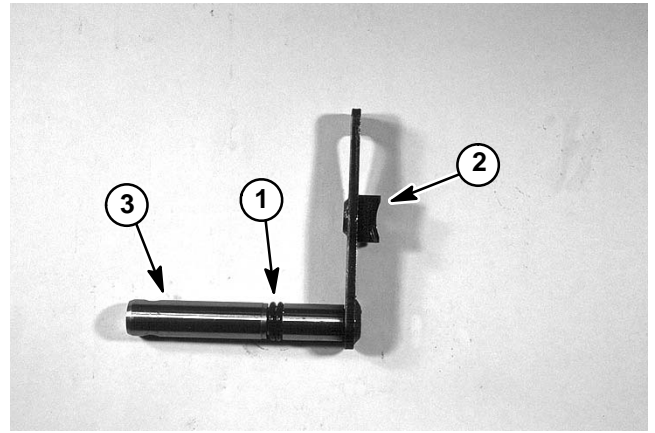

Figure 129

- 1. O-ring (2)
- 2. Spring pin (2)
- 3. Shift arm

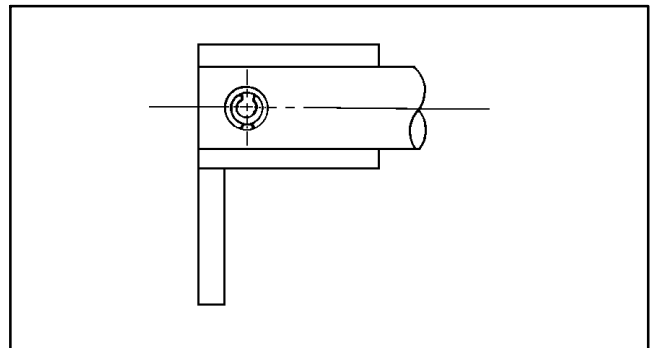

Figure 130



Figure 131

4. Assemble PTO output shaft:

- A. If bearing was removed, use a press to install bearing onto output shaft.
- B. Install washer and retaining ring.
- C. Install retaining ring and gear.
- D. Use a press to install bearing.

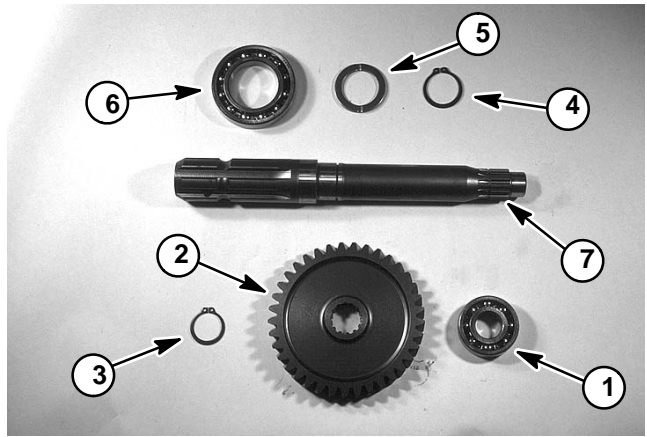

Figure 132

- 1. Bearing
- 2. Gear
- 3. Retaining ring
- 4. Retaining ring
- 5. Thrust washer
- 6. Bearing
- 7. Output shaft

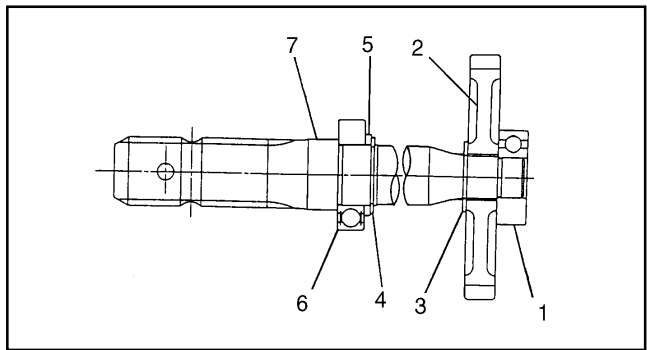

Figure 133

- 1. Bearing
- 2. Gear
- 3. Retaining ring
- 4. Retaining ring
- 5. Thrust washer
- 6. Bearing
- 7. Output shaft

5. Use a press to install bearing onto intermediate shaft.

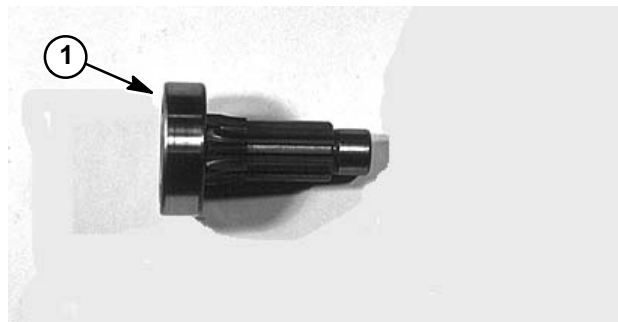

Figure 134

- 1. Bearing

6. Assemble PTO input shaft:

- A. Insert spring and steel balls into hole.
- B. Insert shift collar onto input shaft.
- C. Move shift collar to "ON" position.

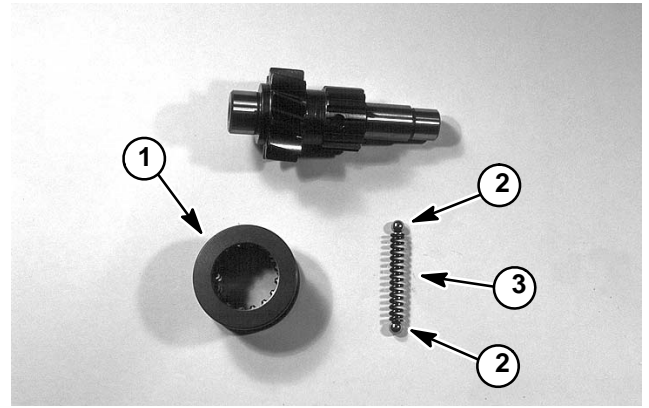

Figure 135

- 1. Shift collar
- 2. Steel ball (2)

- 3. Spring

7. Install PTO input shaft sub-assembly:

A. Insert shifter block onto pin of shift arm. Apply moly disulfide grease onto both sides of block before installing.

B. Put shift collar of PTO input shaft sub-assembly on the shifter block.

C. Install gear with bushing and thrust washer onto input shaft after sliding the assembly toward PTO shaft. Apply moly disulfide grease to bushing of gear and thrust washer before installing.

D. Slide bearings onto input shaft.

E. Install retaining rings.

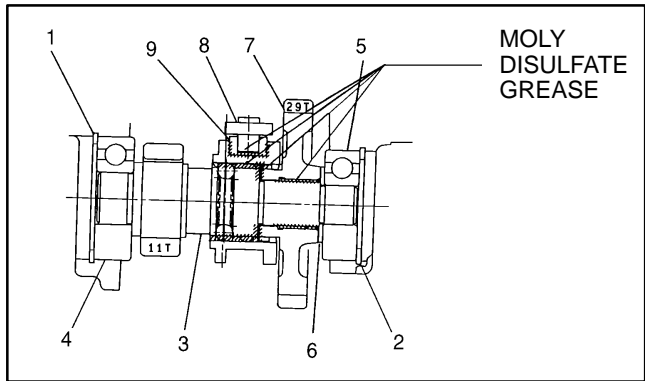

Figure 136

- |                         |                  |
|-------------------------|------------------|
| 1. Retaining ring       | 6. Thrust washer |
| 2. Retaining ring       | 7. Gear          |
| 3. Input shaft assembly | 8. Shift arm     |
| 4. Bearing              | 9. Shifter block |
| 5. Bearing              |                  |

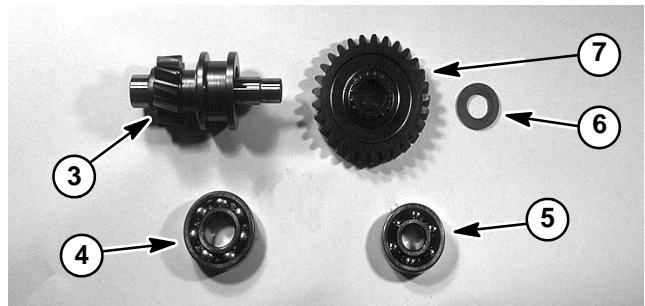

Figure 137

- |                         |                  |
|-------------------------|------------------|
| 3. Input shaft assembly | 6. Thrust washer |
| 4. Bearing              | 7. Gear          |
| 5. Bearing              |                  |

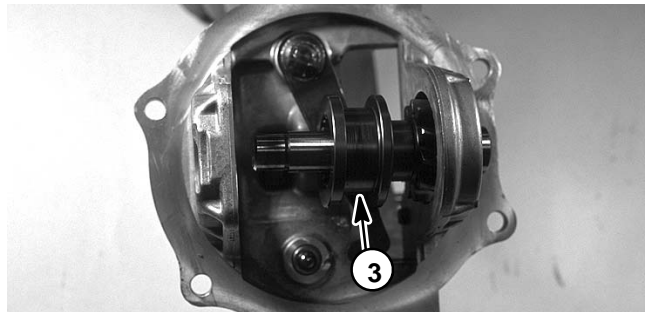

Figure 138

3. Input shaft assembly

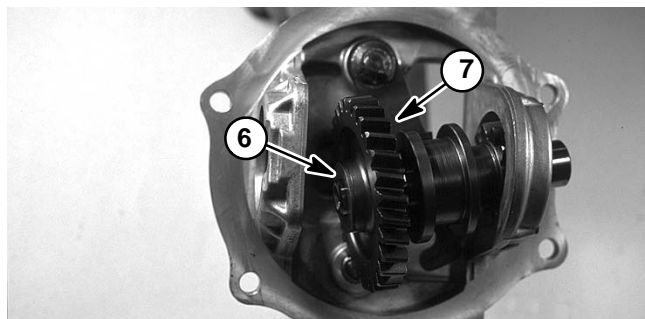

Figure 139

- |                  |         |
|------------------|---------|
| 6. Thrust washer | 7. Gear |
|------------------|---------|

8. Install PTO intermediate shaft sub-assembly:

- A. If removed during disassembly, insert bearing into PTO housing.
- B. Put gear on mating gear.
- C. Move gear until bores of gear and bearing line up.
- D. Insert intermediate shaft sub-assembly. Apply grease to intermediate shaft to aid assembly.

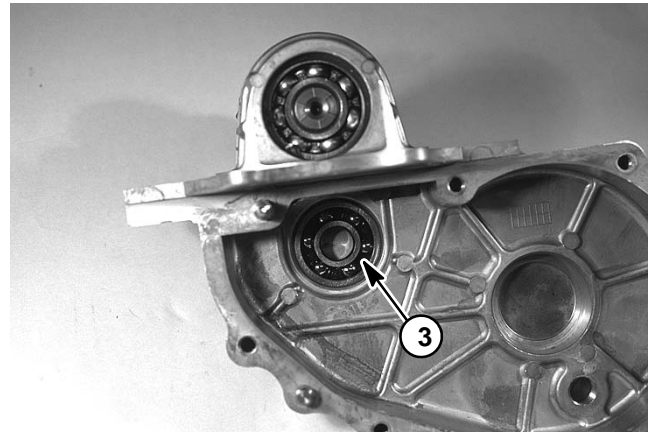

Figure 140

3. Bearing

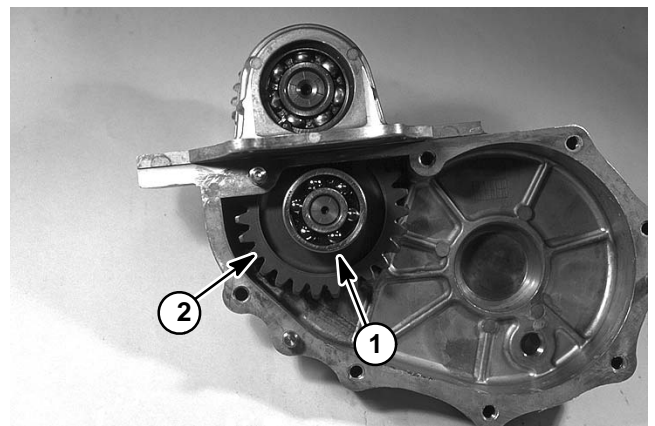

Figure 141

1. Intermediate shaft sub-assembly

2. Gear

9. Insert PTO shaft assembly into bearing housing of PTO housing.

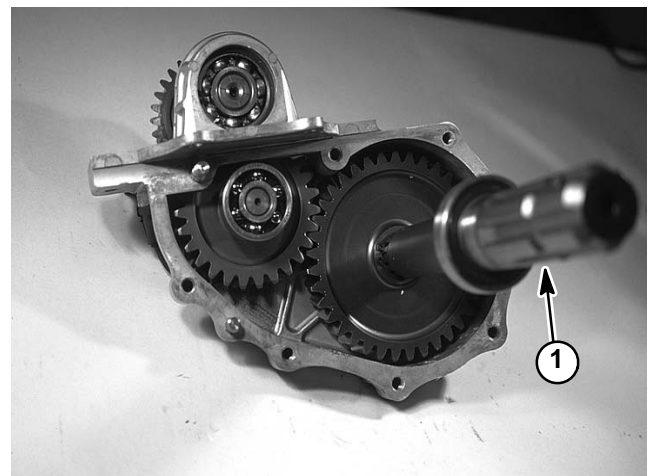

Figure 142

1. PTO shaft assembly

10. Install PTO cover:

- A. Insert new oil seal into PTO cover. Apply multi-purpose grease to lip of oil seal.
- B. Insert alignment pins into PTO housing.
- C. Apply silicone sealant onto mating surface of PTO cover.
- D. Install PTO cover. Secure cover with cap screws, nut and lock washers. Torque fasteners from **18 to 22 ft-lb (24.5 to 29.5 N-m)**.

11. Install PTO to transaxle (see PTO Removal and Installation in this chapter).

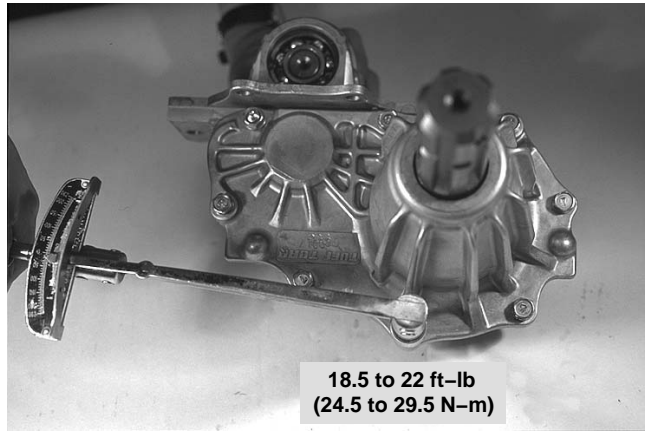

Figure 143



Table of Contents

SPECIFICATIONS .....	2	Brake Master Cylinder .....	16
GENERAL INFORMATION .....	3	Brake Master Cylinder Service .....	18
Operator's Manual .....	3	Parking Brake Cable .....	20
Tire Pressure .....	3	Wheel Hub .....	22
SPECIAL TOOLS .....	4	Steering Assembly .....	24
TROUBLESHOOTING .....	5	Front Control Arms .....	28
Suspension and Steering .....	5	Front Compression Spring Service .....	30
Brakes .....	6	Front Shock Absorber .....	32
SERVICE AND REPAIRS .....	8	Rear Shock Absorber .....	33
Wheel Assembly .....	8	Rear Leaf Spring .....	34
Brake System .....	10	Front Wheel Alignment .....	36
Brake Caliper Service .....	12	Steering Wheel .....	37
Bleed Brake System .....	14	Seat Base .....	38
Parking Brake Caliper Service .....	15	Hood .....	40

# Specifications

Item	Specification
Front tire	20" x 9" – 12, 6 ply
Maximum front tire pressure*	32 PSI (220 kPa)
Front wheel alignment	0 ± 0.120 in. (0 ± 3 mm)
Rear tire	24" x 12" – 12, 6 ply Model 07383 = 24" x 13" – 12, 6 ply Model 07379 (Industrial) = 23" x 10.5" – 12, 4 ply
Maximum rear tire pressure*	18 PSI (124 kPa) Model 07383 = 28 PSI (193 kPa) Model 07379 (Industrial) = 20 PSI (138 kPa)
Wheel nut torque	80 to 90 ft–lb (109 to 122 N–m)
Brake fluid	DOT 3
Brake rotor	Minimum thickness = 0.154" (3.9 mm)
Service Brake pads	Minimum thickness = 1/16" (1.6 mm)
Parking Brake pads	Minimum thickness = 0.135" (3.4 mm)

\*For proper 4WD operation, keep tires at maximum pressure.



# General Information

---

## Operator's Manual

The vehicle Operator's Manual provides information regarding the operation, general maintenance and maintenance intervals for your Workman vehicle. Refer to the Operator's Manual for additional information when servicing the vehicle.

---

## Tire Pressure

1. Tire pressure should be determined by the payload carried.
2. Maximum tire pressures will reduce turf compaction, tire marks, and create the best tire footprint.
3. Lower tire pressure should not be used for heavy payloads at higher speeds. Tire damage may result.
4. Higher tire pressure should be used for heavier payloads at higher speeds. Do not exceed maximum tire pressure (see Specifications).
5. See vehicle Operator's Manual for additional tire, pressure, loading, and towing information.

# Special Tools

## Compression Spring Tool

Use to remove and install the front suspension compression springs.

Quantity	Item
2	1/2" x 20" threaded steel rods
4	1/2" nuts
4	1/2" flat washers

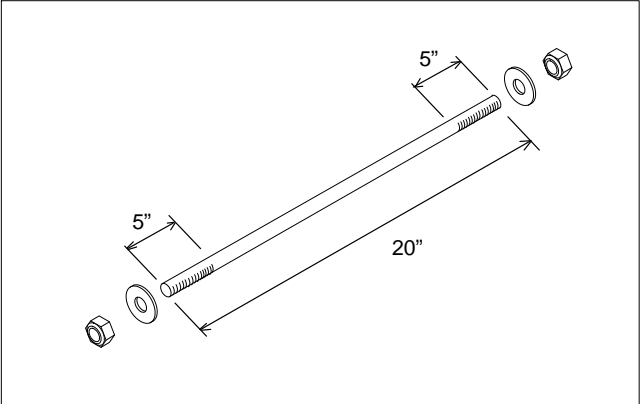

Figure 1

# Troubleshooting

## Suspension and Steering

Problem	Possible Causes
Front end noise.	Loose or worn front wheel bearings. Worn front shock absorbers. Worn stabilizer link bushings. Loose steering components (e.g. tie rods, steering cylinder). Worn control arm bushings. Tire pressure low (4WD vehicles). Worn tires (4WD vehicles).
Rear end noise.	Worn or brinelled rear wheel bearings. Worn rear shock absorbers. Worn leaf spring bushings. Clutch, driveshaft or transaxle problem (see Chapter 6 – Drive Train).
Excessive steering play.	Loose or worn front wheel bearings. Loose or worn steering linkage. Worn tie rod ends.
Front wheel shimmy.	Loose or worn front wheel bearings. Tires out of round or uneven tire wear. Worn tie rod ends. Incorrect front wheel alignment (toe-in). Worn shock absorbers.
Instability (wander).	Low or uneven tire pressure. Worn or loose wheel bearings. Worn steering linkage bushings. Broken or loose rear leaf spring. Worn shock absorber(s). Incorrect front wheel alignment (toe-in). Worn or loose ball joints.

## Suspension and Steering (Continued)

Problem	Possible Causes
Hard steering.	Loose, worn or glazed hydraulic pump drive belt (Workman HD vehicles). Binding or damaged steering linkage. Low or uneven tire pressure. Low hydraulic pressure (see Chapter 9 – Hydraulic System). Damaged or binding steering cylinder. Worn or damaged steering control valve. Incorrect front wheel alignment.
Vehicle pulls to one side when not braking.	Low or uneven tire pressure. Broken or weak rear leaf spring. Incorrect front wheel alignment. Damaged or bent suspension or steering component. Worn or damaged brake components.

## Brakes

Problem	Possible Causes
Brake pedal goes to floor.	Low brake fluid level. Air in brake system. Leaking wheel caliper(s). Loose or broken brake lines. Leaking or worn brake master cylinder. Excessively worn brake pads or rotors.
Spongy brake pedal.	Air in brake system. Excessively worn brake pads or rotors. Broken or worn brake pedal pivot bushing.
Squealing brakes.	Glazed, saturated or worn brake pads. Contaminants on brake pads and/or rotors. Missing anti-rattle clip in brake caliper. Scored or bent brake rotors.

## Brakes (Continued)

Problem	Possible Causes
Brakes pulling.	Incorrect tire pressure. Contaminated brake pads. Front end is out of alignment. Bent or damaged brake rotors. Damaged brake hoses. Parking brake caliper or cable is sticking or damaged. Unmatched tires on same axle.
Dragging brakes.	Parking brake is engaged or sticking. Improper parking brake adjustment. Weak or broken parking brake return spring. Binding brake pedal. Sticking brake master cylinder. Saturated brake pads. Scored or bent brake rotors.
Hard brake pedal.	Incorrect brake pad material. Damaged brake hoses. Brake pedal linkage is binding.
Wheel locks.	Contaminated brake pads. Loose or damaged brake pads. Wheel caliper is sticking. Sticking brake master cylinder. Wheel bearing is seized.
Brakes fade.	Overheated brake rotors. Saturated brake pads.
Brakes surge at slow speeds and chatter at fast speeds.	Warped or unevenly worn brake rotors.

# Service and Repairs

## Wheel Assembly

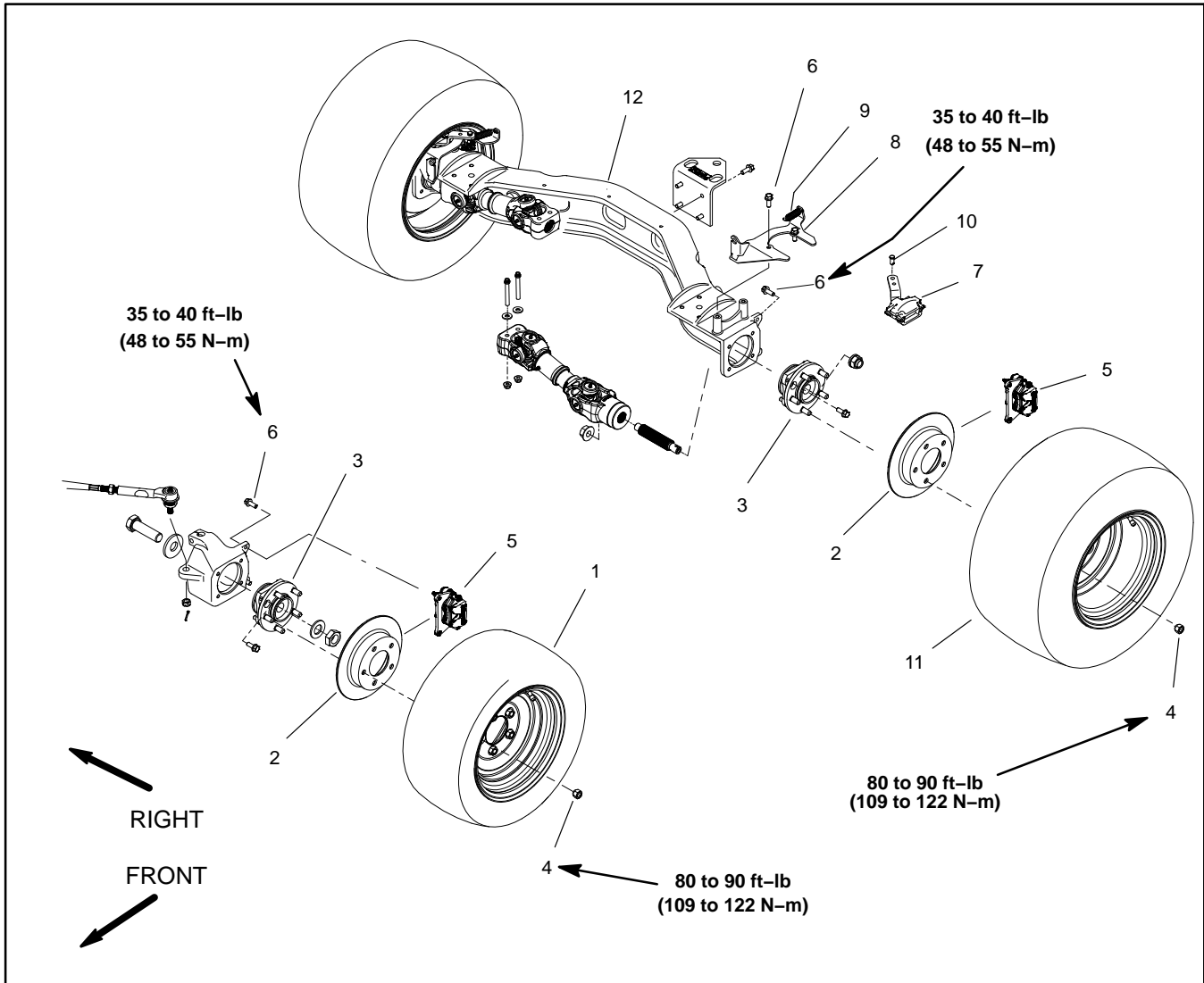

Figure 2

- 1. Front wheel assembly
- 2. Brake rotor
- 3. Wheel hub assembly
- 4. Lug nut (5 per wheel)

- 5. Brake caliper
- 6. Flange head screw
- 7. Parking brake caliper (LH)
- 8. Parking brake bracket (LH)

- 9. Parking brake return spring
- 10. Clevis pin (2)
- 11. Rear wheel assembly
- 12. Rear axle

### Removal (Fig. 2)

1. Park vehicle on a level surface, shut engine off, remove key from ignition switch and apply parking brake.
2. Partially loosen wheel lug nuts that secure wheel to be removed, then jack up and support vehicle (see Jacking Vehicle in Chapter 1 – Safety in this manual).
3. Remove lug nuts and then remove wheel assembly from vehicle.

### Installation (Fig. 2)

1. Install wheel. Secure with five (5) lug nuts.
2. Lower vehicle to ground.

	<b>WARNING</b>
<b>Failure to maintain proper wheel lug nut torque could result in failure or loss of wheel and may result in personal injury. Torque wheel lug nuts from 80 to 90 ft-lb (109 to 122 N-m).</b>	

3. Wheel lug nuts should be tightened in a star pattern (Fig. 3) and in two (2) steps. First, tighten all lug nuts to **40 ft-lb (55 N-m)** and then torque all lug nuts to a final torque from **80 to 90 ft-lb (109 to 122 N-m)**.

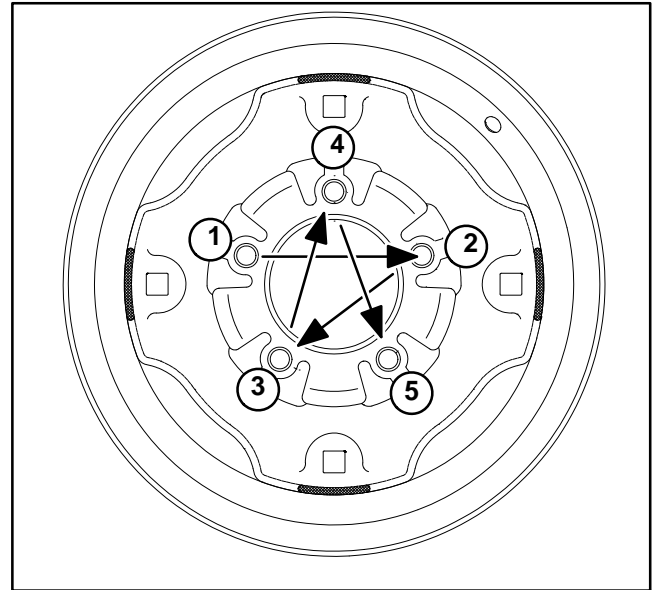

Figure 3

# Brake System

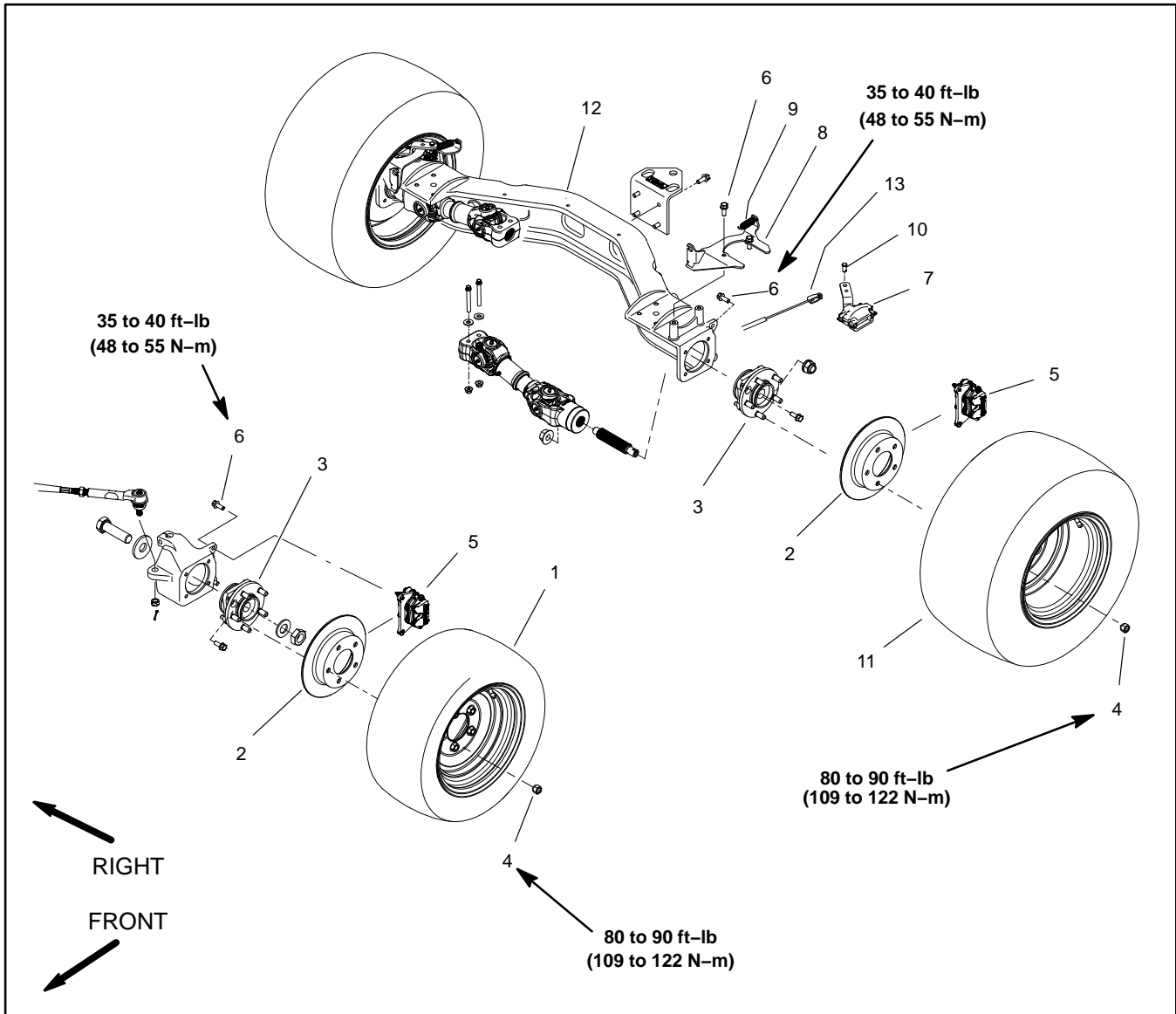



Figure 4

- |                          |                                     |                             |
|--------------------------|-------------------------------------|-----------------------------|
| 1. Front wheel assembly  | 6. Flange head screw                | 10. Clevis pin              |
| 2. Brake rotor           | 7. Parking brake caliper (LH shown) | 11. Rear wheel assembly     |
| 3. Wheel hub assembly    | 8. Parking brake bracket (LH shown) | 12. Rear axle               |
| 4. Lug nut (5 per wheel) | 9. Parking brake return spring      | 13. Parking brake cable (2) |
| 5. Brake caliper         |                                     |                             |



### Disassembly (Fig. 4)

1. Park vehicle on a level surface, shut engine off, remove key from ignition switch and apply parking brake.

**WARNING**

**Before jacking up the machine, review and follow Jacking Instructions in Chapter 1 – Safety.**

2. Chock wheels not being jacked up. For brake that is to be serviced, jack wheel off the ground and place appropriate jack stand beneath the frame to support vehicle.

3. Remove wheel from vehicle (see Wheel Assembly in this section).

4. Disconnect brake line from caliper (Fig. 5):

A. Clean hydraulic brake line area of brake caliper to prevent contamination.

B. Remove banjo bolt from caliper brake line from caliper.

C. Carefully separate brake line from caliper. Locate and retrieve two (2) banjo washers from sides of brake line fitting.

D. Plug brake line and position it away from caliper.

5. Remove two (2) flange head screws that secure the brake caliper to the machine.

6. Slide brake caliper from brake rotor and remove caliper from vehicle.

### Assembly (Fig. 4)

1. Slide brake caliper onto brake rotor. Make sure that rotor is between brake pads.

2. Align caliper with mounting holes. Secure caliper with two (2) flange head screws. Torque screws from **35 to 40 ft-lb (48 to 55 N-m)**.

3. Connect brake line to caliper (Fig. 5):

A. Position brake line to caliper.

B. Place banjo washer on each side of brake line fitting.

C. Install banjo bolt through brake line fitting and banjo washers and then thread into caliper. Torque banjo bolt from **108 to 132 in-lb (12.3 to 14.9 N-m)**.

4. Install wheel to vehicle (see Wheel Assembly in this section).

5. Lower machine to ground.

**WARNING**

**Failure to maintain proper wheel lug nut torque could result in failure or loss of wheel and may result in personal injury. Torque wheel lug nuts from 80 to 90 ft-lb (109 to 122 N-m).**

6. Torque wheel lug nuts in a crossing pattern from **80 to 90 ft-lb (109 to 122 N-m)**.

7. Bleed brakes (see Bleed Brake System in this section).

**CAUTION**

**After servicing brake system components, always check the brakes in a wide open, level area that is free of other persons and obstructions.**

8. After assembly is completed, check brake operation.

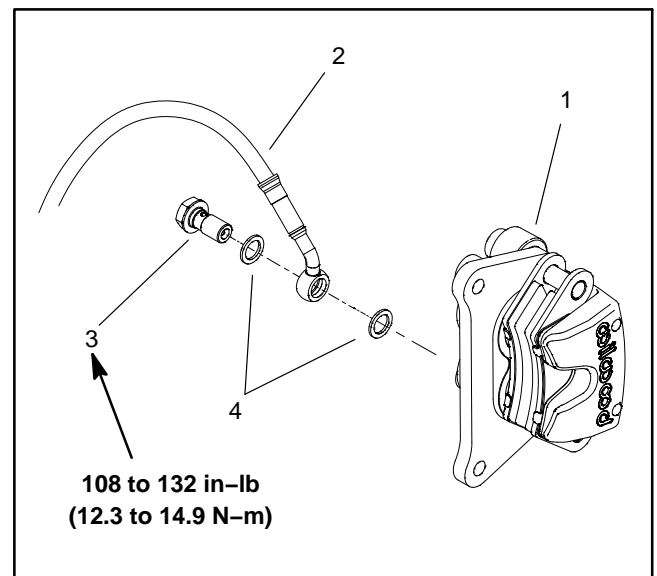

Figure 5

1. Brake caliper
2. Brake line

3. Banjo bolt
4. Banjo washer (2)

# Brake Caliper Service

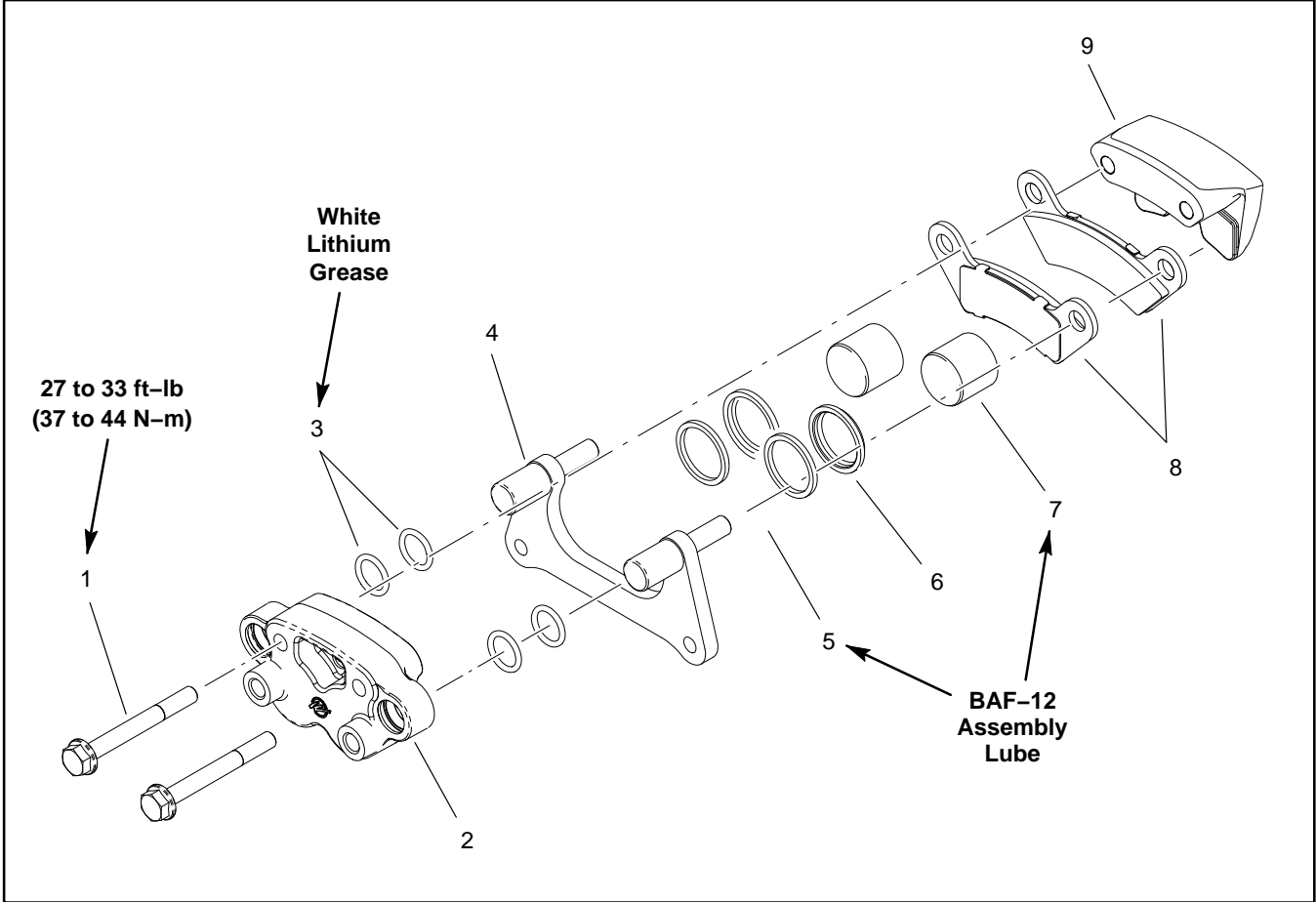

Figure 6

- 1. Bolt (2)
- 2. Caliper body
- 3. O-ring (4)

- 4. Caliper bracket
- 5. Square seal (2)
- 6. Dust seal (2)

- 7. Piston (2)
- 8. Brake pad (2)
- 9. Caliper anvil

### Disassembly (Fig. 6)

1. Remove two (2) bolts that secure brake caliper assembly.
2. Remove caliper anvil and then slide brake pads from pins on caliper bracket.
3. Slide caliper body assembly from caliper bracket.
4. If necessary, remove remaining components from caliper body:
  - A. Carefully remove pistons from caliper body making sure that outer surface of pistons are not damaged during removal.
  - B. Carefully, remove and discard O-rings, dust seals and square seals from caliper body. Make sure that caliper body is not damaged during removal of O-rings and seals.
5. Clean caliper components with brake cleaner.

### Inspection

1. Check brake pads for uneven wear that would indicate binding in the caliper assembly. Replace the brake pads if the friction material is worn to less than 1/16" (1.6 mm). Also, if pads are contaminated with grease or oil, they must be replaced.
2. Inspect brake pistons and piston bores in caliper body for damage or wear. Replace brake pistons or complete brake caliper assembly if necessary.
3. Check that pins on caliper bracket are not worn or damaged. Wear on the pins will prevent smooth brake operation.

### Assembly (Fig. 6)

1. If caliper body was disassembled, install components in caliper body:
  - A. Apply hydraulic brake cylinder assembly lube (BAF-12 or equivalent) to square seals and pistons before installation.
  - B. Fit lubricated square seals into grooves of caliper body. Make sure that seals are not twisted in groove after installation.
  - C. Install lubricated pistons into caliper body bores. Pistons should slide into bores with light resistance.
  - D. Install dust seals into caliper body.
  - E. Lubricate O-rings with white lithium grease and install into grooves in caliper body.
  - F. Slide caliper body assembly onto pins on caliper bracket.

**NOTE:** If brake pads are being replaced, it will be necessary to push caliper pistons back into the caliper bore before installing new pads.

2. Slide brake pads onto pins on caliper bracket. Make sure that friction material on pads is toward brake rotor position.
3. Fit caliper anvil to assembly and secure caliper components with two (2) bolts. Torque bolts from **27 to 33 ft-lb (37 to 44 N-m)**.

## Bleed Brake System

1. Remove hood to access brake master cylinder (see Hood in this section). Make sure that brake fluid level is correct.
2. Connect a suitable transparent hose to bleeder valve on left rear wheel caliper and submerge other end of hose in a clean glass container partially filled with clean brake fluid.
3. Have a second person pump brake pedal several times, then hold pedal down firmly.
4. With pedal firmly depressed, open bleeder valve of left rear brake until pedal fades to floor, then close bleeder valve.
5. Repeat procedure until a continuous flow of brake fluid, with no air bubbles, is released from bleeder valve. **Make sure fluid level is maintained in brake fluid reservoir at all times.**
6. Torque bleeder valve from **54 to 66 in-lb (6.2 to 7.4 N-m)**.
7. Complete steps 2 through 6 for right rear, left front and then right front brake calipers.
8. Install hood (see Hood in this section).

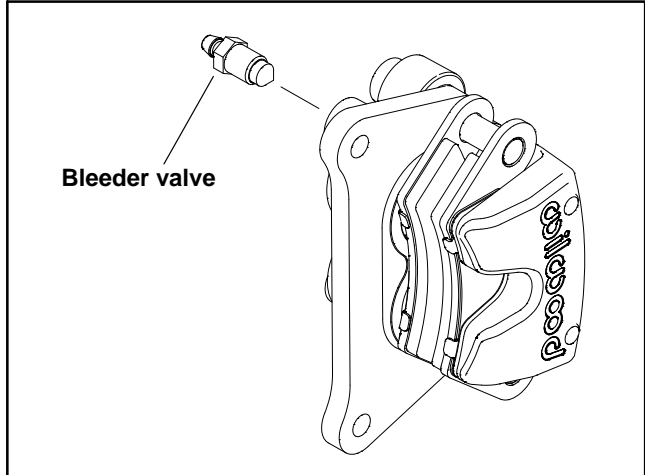

Figure 7



### CAUTION

**After servicing the brakes, always check the brakes in a wide open, level area that is free of other persons and obstructions.**

9. After bleeding of brakes is completed, test vehicle to make sure brakes are operating correctly and brake pedal is solid.

## Parking Brake Caliper Service

### Disassembly (Fig. 8)

1. Remove carrier side brake pad and pad support from caliper.
2. Remove cam side brake pad and pad support from caliper.
3. Replace the brake pads if the friction material is worn to less than 0.135" (3.4 mm).
4. If necessary, remove lever retainer spring, pivot pins and cam lever from caliper body.

### Assembly (Fig. 8)

1. If removed, install cam lever into caliper body and then place pivot pins into lever holes. Insert lever retainer spring with tangs bent away from housing until the spring tabs contact the pivot pin at the bottom of the housing pocket.
2. Install cam side pad support (notch facing cam lever) and brake pad into caliper body.
3. Slide carrier side pad support and brake pad into caliper body.

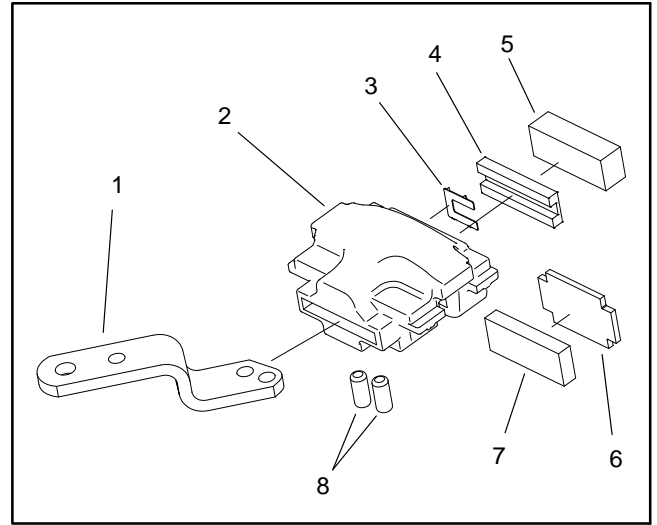

Figure 8

- |                          |                           |
|--------------------------|---------------------------|
| 1. Cam lever             | 5. Cam side brake pad     |
| 2. Caliper               | 6. Pad support            |
| 3. Lever retainer spring | 7. Carrier side brake pad |
| 4. Pad support           | 8. Pivot pin              |

# Brake Master Cylinder

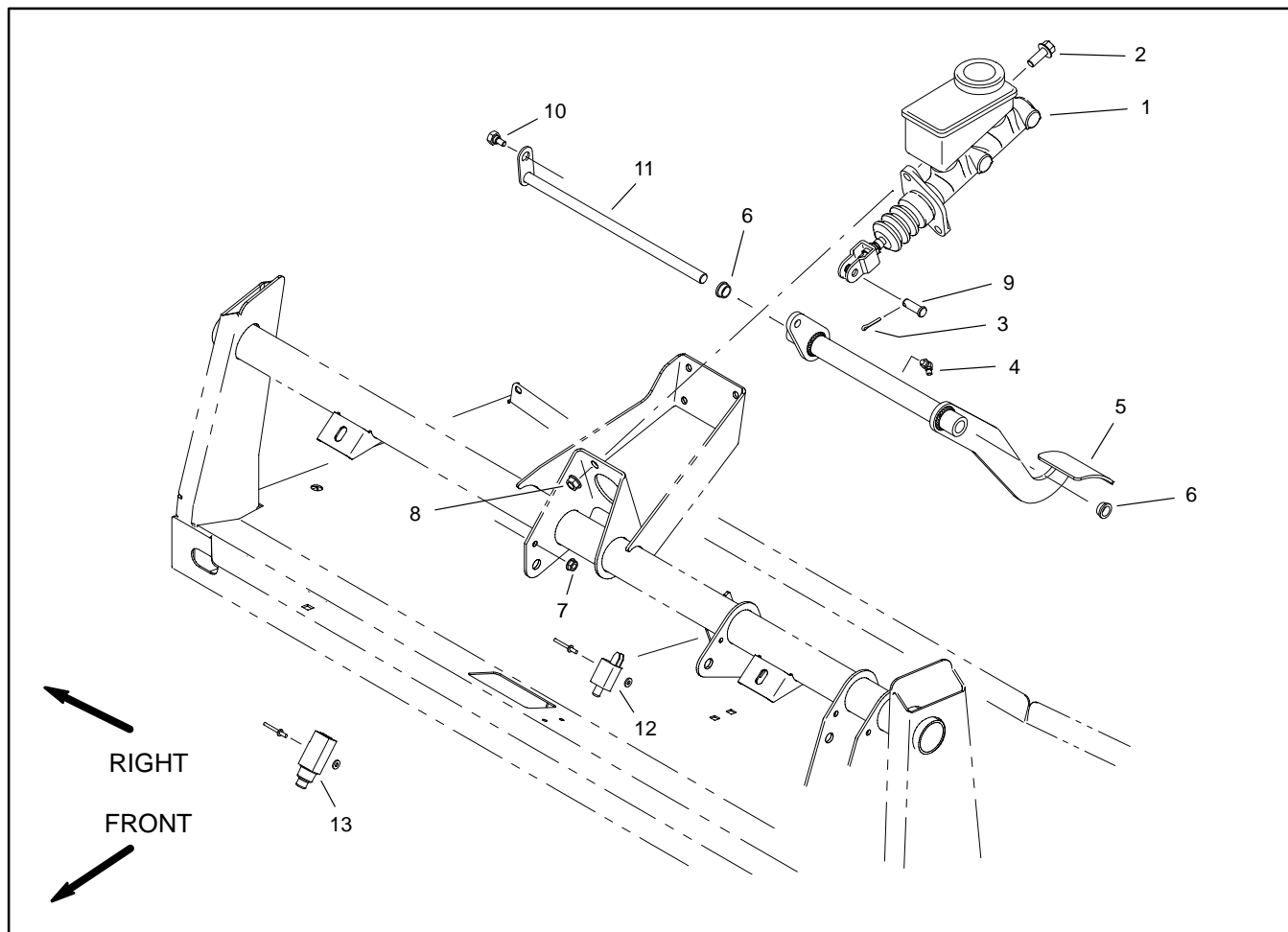

Figure 9

- |                          |                   |                               |
|--------------------------|-------------------|-------------------------------|
| 1. Brake master cylinder | 6. Flange bushing | 10. Shoulder screw            |
| 2. Flange head screw (2) | 7. Flange nut     | 11. Brake shaft               |
| 3. Clevis pin            | 8. Flange nut (2) | 12. Brake switch (2WD models) |
| 4. Grease fitting        | 9. Cotter pin     | 13. Brake switch (4WD models) |
| 5. Brake pedal           |                   |                               |

### Removal (Fig. 9)

1. Park vehicle on a level surface, shut engine off, remove key from ignition switch and apply parking brake.
2. Remove hood to access brake master cylinder (see Hood Removal in this section).
3. Remove cotter pin from the clevis pin that connects master cylinder to brake pedal.
4. Clean hydraulic brake line area of master cylinder to prevent contamination. Remove both brake lines from master cylinder. Cap ends of brake lines and position them away from master cylinder.
5. Remove two (2) flange head screws and flange nuts that secure master cylinder to vehicle frame.
6. Remove master cylinder from vehicle.

### Installation (Fig. 9)

1. Position master cylinder to vehicle frame and secure with two (2) flange head screws and flange nuts.
2. Remove plugs from brake lines. Install brake lines to master cylinder. Make sure that brake lines are properly connected to master cylinder (Fig. 10).
3. Make sure that master cylinder push rod is fully extended. Connect push rod clevis to brake pedal with clevis pin and cotter pin.
4. Bleed brakes (see Bleed Brake System in this section).
5. Install hood (see Hood Installation in this section).



## CAUTION

After servicing the brakes, always check the brakes in a wide open, level area that is free of other persons and obstructions.

6. Check brake operation.

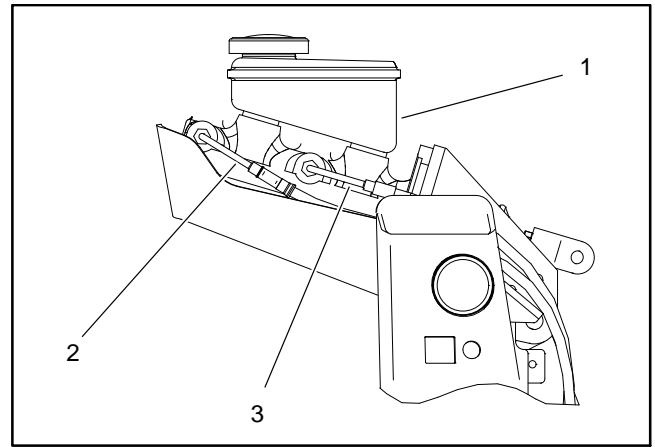

Figure 10

1. Brake master cylinder
2. Front brake line
3. Rear brake line

## Brake Master Cylinder Service

### Disassembly (Fig. 11)

1. Thoroughly clean outside of master cylinder before disassembly.
2. Remove reservoir and flange seal. Push in on the push rod (item 8) so the stop pin (item 3) can be removed.
3. Disconnect lower end of the dust cover from the housing.
4. Push in on the push rod and remove circlip (item 9) from cylinder housing, then remove push rod with dust cover and clevis. Remove retainer washer.
5. Remove primary piston assembly and secondary piston assembly from cylinder housing.

### Inspection



## CAUTION

Use eye protection such as goggles when using compressed air for master cylinder service.

1. Clean all metal parts with isopropyl alcohol, then clean out and dry grooves and passageways with compressed air. Make sure cylinder bore and component pieces are thoroughly clean.
2. Check cylinder bore, pistons and springs for damage or excessive wear. Replace brake cylinder assembly if signs of pitting, scoring or cracks are evident in cylinder bore.

### Assembly (Fig. 11)

1. Apply a film of clean brake fluid to cylinder bore and piston assemblies.
2. Install secondary piston assembly and primary piston assembly into cylinder.
3. Install retainer washer.
4. Install push rod and secure in place with circlip. Install lower end of dust cover to housing.
5. Push in on push rod so stop pin can be installed to retain secondary piston assembly, then install flange seal and reservoir.

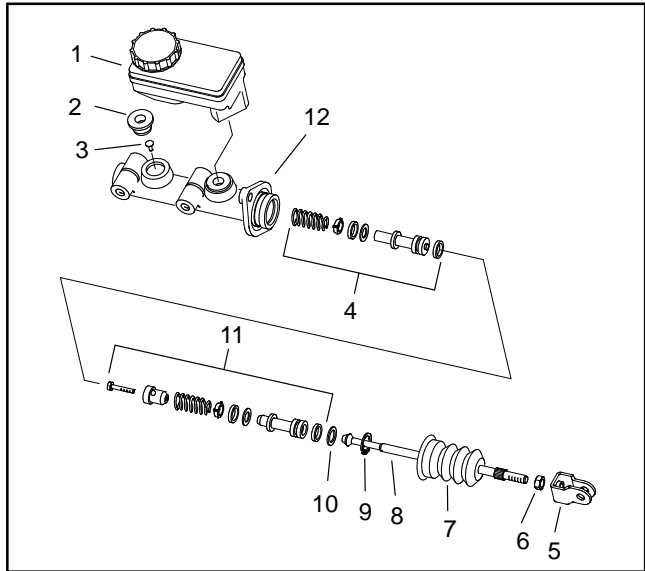

Figure 11

- |                          |                         |
|--------------------------|-------------------------|
| 1. Reservoir             | 7. Dust cover           |
| 2. Flange seal           | 8. Push rod             |
| 3. Stop pin              | 9. Circlip              |
| 4. Secondary piston assy | 10. Retainer washer     |
| 5. Clevis                | 11. Primary piston assy |
| 6. Jam nut               | 12. Cylinder housing    |



This page is intentionally blank.

## Parking Brake Cable

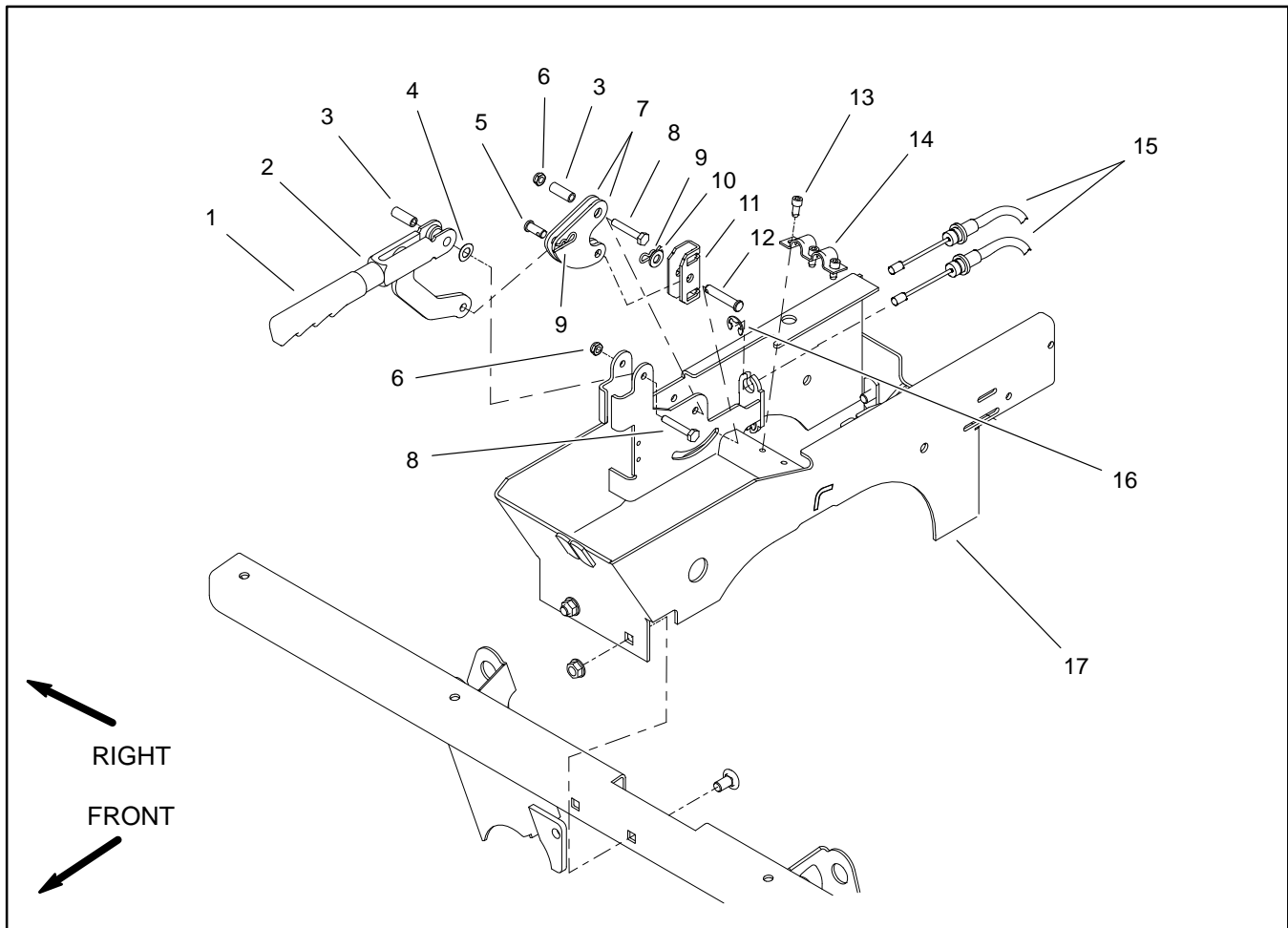

Figure 12

- |                               |                             |                            |
|-------------------------------|-----------------------------|----------------------------|
| 1. Parking brake lever handle | 7. Bellcrank                | 13. Socket head screw (3)  |
| 2. Parking brake lever        | 8. Cap screw                | 14. Cable clamp            |
| 3. Spacer                     | 9. Hair pin                 | 15. Parking brake cable    |
| 4. Curved washer              | 10. Flat washer             | 16. Retaining ring (2)     |
| 5. Clevis pin                 | 11. Cable equalizer bracket | 17. Lever support assembly |
| 6. Lock nut                   | 12. Clevis pin              |                            |

### Removal (Fig. 12)

1. Park vehicle on a level surface, shut engine off and remove key from ignition switch.
2. Remove brake lever handle from parking brake lever. Loosen set screw on parking brake lever knob. Turn knob on parking brake lever counterclockwise all the way to loosen brake cable adjustment.
3. Jack up and support rear of vehicle (see Jacking Vehicle in Chapter 1 – Safety in this manual). Make sure that vehicle is supported with jack stands.
4. For parking brake cable that is to be serviced, remove rear wheel from vehicle (see Wheel Assembly Removal in this section).

5. Disconnect brake cable from parking brake caliper on rear axle (Fig. 13):

A. Loosen cable jam nuts that secure parking brake cable to parking brake bracket.

B. Remove brake return spring end from clevis pin on parking brake caliper lever.

C. Disconnect brake cable from parking brake bracket and caliper lever.

6. Remove knobs from control levers and then remove center console control plate to gain access to parking brake cables in console.

7. Remove retaining ring that secures brake cable to lever support assembly.

8. Disconnect brake cable from cable equalizer bracket (Fig. 14).

9. Note routing of parking brake cable and location of cable ties to secure brake cable to vehicle frame. Remove brake cable from vehicle.

### Installation (Fig. 12)

1. Route new brake cable in same location as before and secure with cable ties. Start from rear of vehicle and work towards front.

2. Connect brake cable to parking brake caliper on rear axle (Fig. 13).

A. Connect parking brake cable to parking brake caliper lever with clevis pin.

B. Secure clevis pin by inserting return spring end into clevis pin.

C. Tighten cable jam nuts to secure parking brake cable to brake bracket. Position jam nuts so that all threads on cable are showing towards the rear of the vehicle.

3. Install brake cable end to brake equalizer on parking brake lever. Secure brake cable to lever support assembly with retaining ring (Fig. 14).



## WARNING

Failure to maintain proper wheel lug nut torque could result in failure or loss of wheel and may result in personal injury. Torque wheel lug nuts from 80 to 90 ft-lb (109 to 122 N-m).

4. Install rear wheel (see Wheel Installation in this section). Lower vehicle to ground and make sure that wheel lug nuts are properly torqued from 80 to 90 ft-lb (109 to 122 N-m).

5. Secure center console control plate to seat base with removed screws. Torque screws a maximum of 12 in-lb (1.3 N-m).

6. Install control lever knobs.

7. Adjust parking brake lever (see vehicle Operator's Manual) and check operation of brakes before returning the vehicle to service.

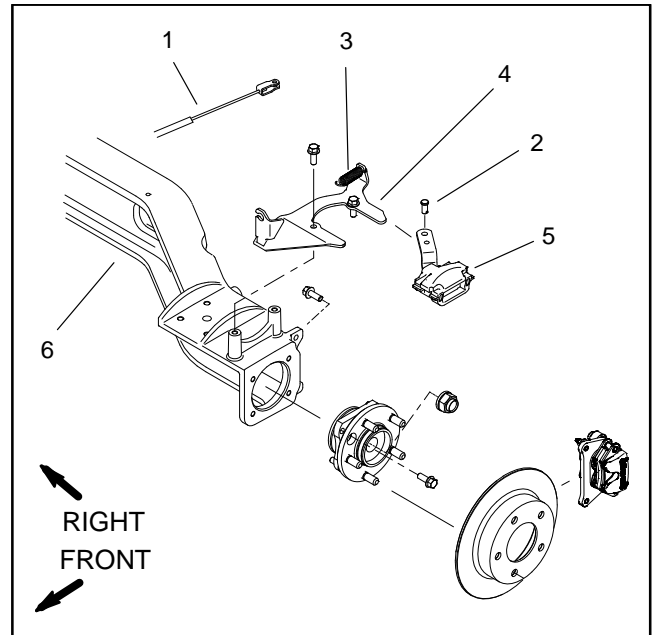

Figure 13

- |                        |                          |
|------------------------|--------------------------|
| 1. Parking brake cable | 4. Parking brake bracket |
| 2. Clevis pin          | 5. Parking brake caliper |
| 3. Brake return spring | 6. Rear axle             |

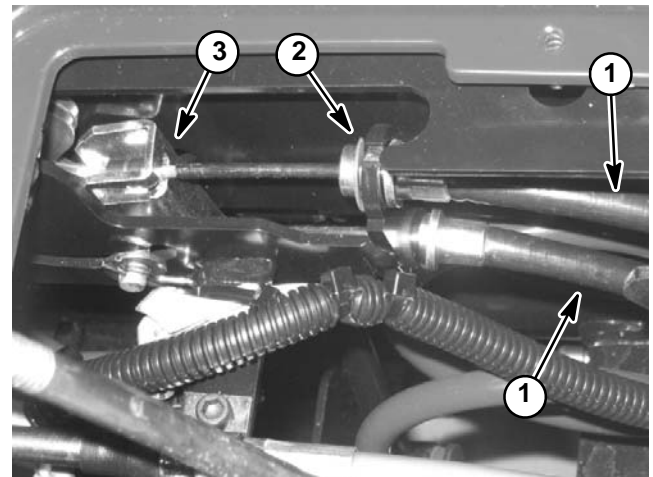

Figure 14

- |                            |                      |
|----------------------------|----------------------|
| 1. Brake cable             | 3. Equalizer bracket |
| 2. Retaining ring location |                      |

# Wheel Hub

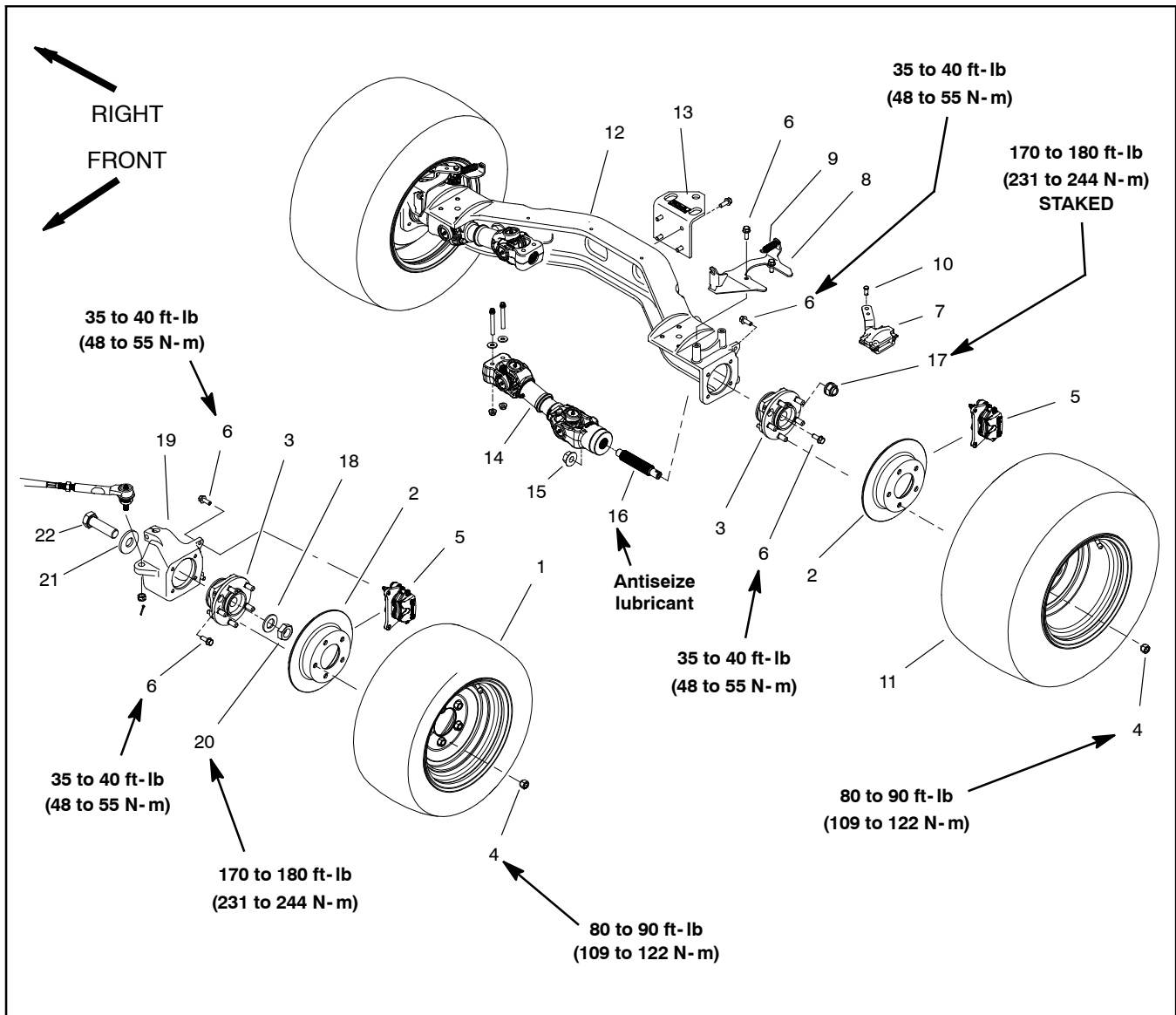

Figure 15

- |                                     |                                |                        |
|-------------------------------------|--------------------------------|------------------------|
| 1. Front wheel assembly             | 9. Parking brake return spring | 16. Splined shaft      |
| 2. Brake rotor                      | 10. Clevis pin                 | 17. Spindle nut        |
| 3. Wheel hub assembly               | 11. Rear wheel assembly        | 18. Flat washer        |
| 4. Lug nut (5 per wheel)            | 12. Rear axle                  | 19. Knuckle (LH shown) |
| 5. Brake caliper                    | 13. Parking brake cable (2)    | 20. Lock nut           |
| 6. Flange head screw                | 14. Driveshaft                 | 21. Hardened washer    |
| 7. Parking brake caliper (LH shown) | 15. Flange nut                 | 22. Cap screw          |
| 8. Parking brake bracket (LH shown) |                                |                        |

**NOTE:** If vehicle is equipped with 4WD, see CV Axle Assembly in Chapter 10 - Front Wheel Drive (4WD) in this manual for front wheel hub removal and installation procedure.

## Removal (Fig. 15)

1. Park vehicle on a level surface, shut engine off and remove key from ignition switch.
2. Jack up and support rear of vehicle (see Jacking Vehicle in Chapter 1 - Safety in this manual). Make sure that vehicle is supported with jack stands.
3. For wheel hub to be serviced, remove wheel, brake caliper and brake rotor (see Brake System Disassembly in this section).

**IMPORTANT: Spindle nuts are staked (deformed) to the splined shaft during assembly. Clear away the deformed area of the nut before removing the nut from the shaft or damage to the shaft threads will occur.**

4. If rear wheel hub is to be removed, remove spindle nut that secures splined shaft to wheel hub.
5. Using wheel hub hole to access flange head screws, remove screws that secure wheel hub to vehicle. Remove wheel hub from vehicle.
6. Inspect wheel studs in hub and replace studs if damage is identified. Use press to extract stud(s) from hub.

**NOTE:** If wheel hub wear or damage exists, replacement of the wheel hub assembly is necessary. Wheel hubs are not rebuildable.

7. If front wheel hub replacement is necessary, remove cap screw, washers and lock nut from wheel hub assembly so that these components can be installed on replacement hub.

## Installation (Fig. 15)

1. If front wheel hub is being replaced, install cap screw, washers and lock nut to new hub. Torque lock nut from **170 to 180 ft-lb (231 to 244 N-m)**.
2. If any wheel studs were removed from hub, press new stud(s) fully into hub making sure that stud shoulder is tight against hub.
3. If rear wheel hub was removed, apply antiseize lubricant to splined shaft.
4. Position wheel hub to vehicle and secure with four (4) flange head screws. Torque screws from **35 to 40 ft-lb (48 to 55 N-m)**.
5. If rear wheel hub was removed, secure wheel hub to splined shaft with spindle nut. Torque spindle nut from **170 to 180 ft-lb (231 to 244 N-m)**. Then, stake spindle nut end into slot in splined shaft.
6. Install brake rotor, brake caliper and wheel (see Brake System Assembly in this section). Make sure that wheel lug nuts are properly torqued from **80 to 90 ft-lb (109 to 122 N-m)**.

# Steering Assembly

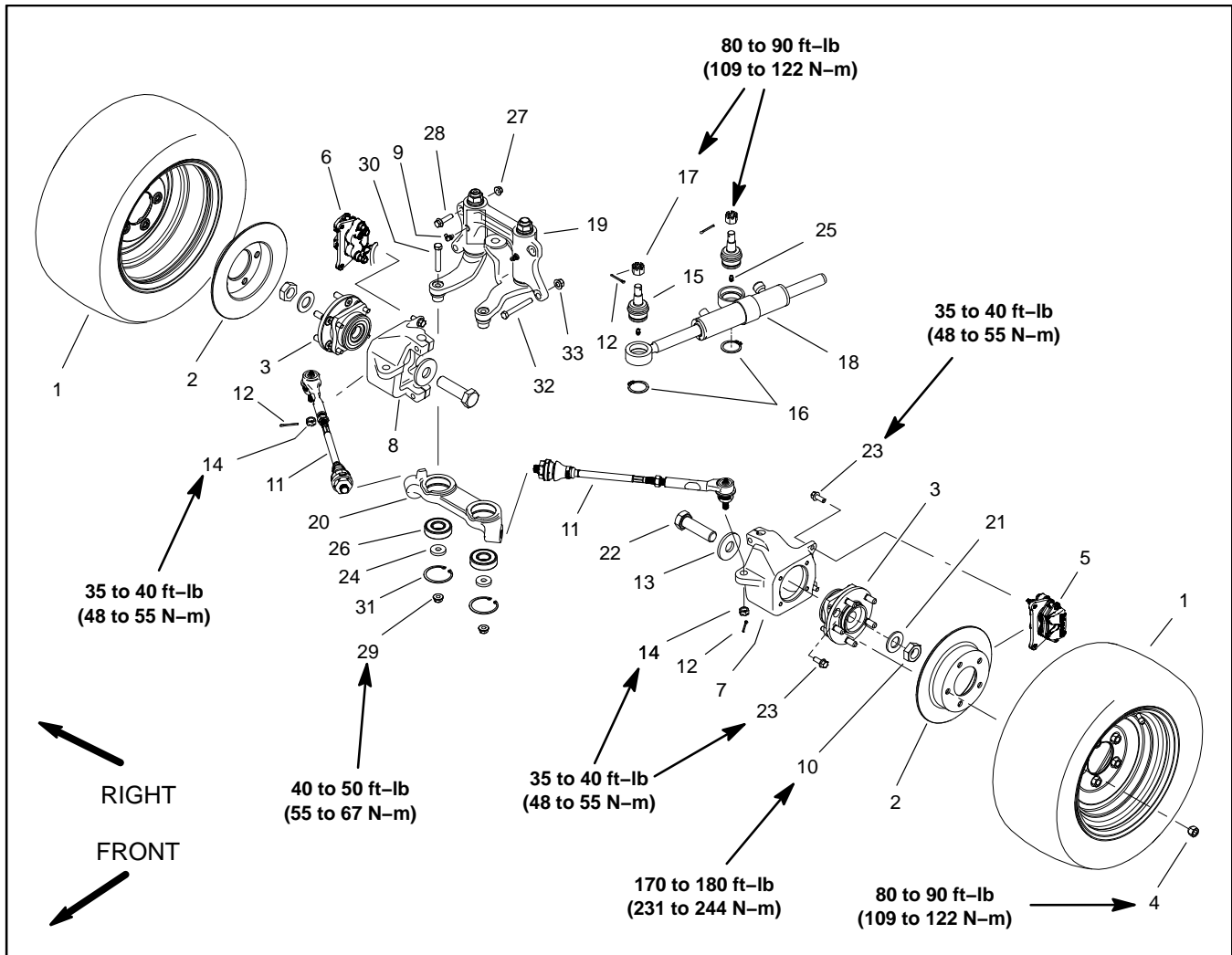

Figure 16

- |   |  |   |
|---|--|---|
| <ul style="list-style-type: none"> <li>1. Front wheel assembly</li> <li>2. Brake rotor</li> <li>3. Wheel hub assembly</li> <li>4. Lug nut (5 per wheel)</li> <li>5. LH brake caliper</li> <li>6. RH brake caliper</li> <li>7. LH knuckle</li> <li>8. RH knuckle</li> <li>9. Grease fitting (2)</li> <li>10. Lock nut (2)</li> <li>11. Tie rod assembly</li> </ul> | <ul style="list-style-type: none"> <li>12. Cotter pin (4)</li> <li>13. Hardened washer (2)</li> <li>14. Slotted hex nut</li> <li>15. Ball joint (2)</li> <li>16. Retaining ring</li> <li>17. Slotted hex nut (2)</li> <li>18. Steering cylinder</li> <li>19. Steering linkage assembly</li> <li>20. Center link</li> <li>21. Flat washer (2)</li> <li>22. Cap screw (2)</li> </ul> | <ul style="list-style-type: none"> <li>23. Flange head screw (12)</li> <li>24. Washer (2)</li> <li>25. Grease fitting (2)</li> <li>26. Ball bearing (2)</li> <li>27. Flange nut (2)</li> <li>28. Flange head bolt (2)</li> <li>29. Flange nut (2)</li> <li>30. Cap screw (2)</li> <li>31. Snap ring (2)</li> <li>32. Cap screw (2)</li> <li>33. Lock nut (2)</li> </ul> |
|---|--|---|

### Disassembly (Fig. 16)

1. Park vehicle on a level surface, shut engine off, remove key from ignition switch and apply parking brake.

2. To remove tie rod from vehicle (Fig. 17):

A. Remove cotter pin and slotted hex nut that secure outer tie rod ball joint stud to knuckle.

B. Use puller to separate ball joint from knuckle.

C. Unscrew inner tie rod end from center link and remove tie rod from vehicle.

D. If necessary, loosen jam nut and remove outer tie rod end from inner tie rod. Count the number of revolutions it takes to remove outer rod end so new rod end can be installed without changing the wheel alignment.

3. To remove steering linkage and center link assembly from vehicle:

A. Remove tie rods from center link (see above).

B. Remove seat base from vehicle (see Seat Base Removal in this section).

C. Remove cotter pin and slotted hex nut that secure steering cylinder ball joint to steering linkage. Separate steering cylinder from steering linkage.

D. Remove fasteners that secure steering linkage and center link assembly to frame. Remove assembly from frame.

E. Disassemble steering linkage and center link assembly as required.

**IMPORTANT: Spindle nuts are staked (deformed) to the idler arm and pitman arm during assembly. Clear away the deformed area of the nut before removing the nut from the arm or damage to the arm threads will occur.**

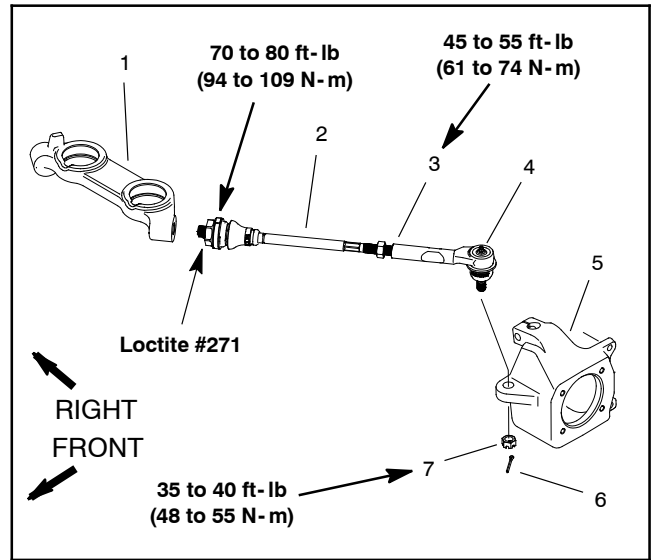

Figure 17

- |                      |                       |
|----------------------|-----------------------|
| 1. Center link       | 5. Knuckle (LH shown) |
| 2. Inner tie rod end | 6. Cotter pin         |
| 3. Jam nut           | 7. Slotted hex nut    |
| 4. Outer tie rod end |                       |

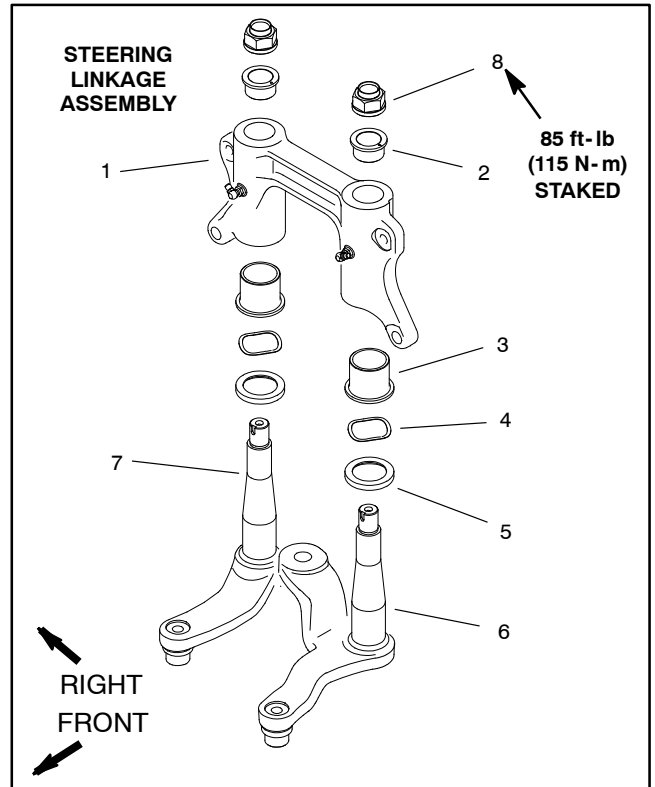

Figure 18

- |                       |                      |
|-----------------------|----------------------|
| 1. Pivot mount        | 5. Thrust washer (2) |
| 2. Flange bushing (2) | 6. Pitman arm        |
| 3. Flange bushing (2) | 7. Idler arm         |
| 4. Wave washer (2)    | 8. Spindle nut (2)   |

## Assembly (Fig. 16)

1. If steering linkage and center link is disassembled (Fig. 17 and 18).
  - A. If flange bushings (Fig. 18) were removed from pivot mount, make sure that new bushings are pressed fully into the pivot mount.
  - B. Fill pivot mount cavities with grease.
  - C. Torque new spindle nut to **85 ft-lb (115 N-m)**. Deform spindle nut into slot in idler arm or pitman arm after torquing nut.
  - D. If bearings were removed from center link, press new bearings fully to the shoulder of the bearing bore in the center link. Secure bearings with retaining ring.
  - E. Secure center link to steering linkage with cap screws, washers and flange nuts. Torque flange nuts from **40 to 50 ft-lb (55 to 67 N-m)**.
2. If steering linkage and center link assembly was removed from vehicle:
  - A. Position assembly to frame and secure with removed fasteners. Torque lock nuts from **40 to 50 ft-lb (55 to 67 N-m)**.
  - B. Secure steering cylinder ball joint to steering linkage with slotted hex nut. Torque slotted hex nut from **80 to 90 ft-lb (109 to 122 N-m)**. If necessary, tighten nut further until slot in nut aligns with hole in ball joint stud. Install cotter pin.
  - C. Install tie rods to center link (see below).
  - D. Install seat base to vehicle (see Seat Base Installation in this section).
3. To install tie rod to vehicle:
  - A. If tie rod was separated, make sure that jam nut is on inner tie rod threads. Thread outer tie rod end onto inner tie rod the same number of revolutions as the old one took to remove.
  - B. Apply Loctite #271 (or equivalent) to threads of inner tie rod end. Thread tie rod into center link and torque from **70 to 80 ft-lb (94 to 109 N-m)**.
  - C. Clean tapers of knuckle and outer tie rod end ball joint stud.
  - D. Insert outer tie rod end ball joint stud into knuckle and secure with slotted hex nut. Torque slotted hex nut from **35 to 40 ft-lb (48 to 55 N-m)**. If necessary, tighten nut further until slot in nut aligns with hole in tie rod ball joint stud. Install cotter pin.
4. Lubricate all grease fittings in steering assembly. Make sure steering linkage assembly pivot mount is completely filled with grease.
5. Check front wheel alignment and adjust if necessary (see Front Wheel Alignment in this section).



This page is intentionally blank.

# Front Control Arms

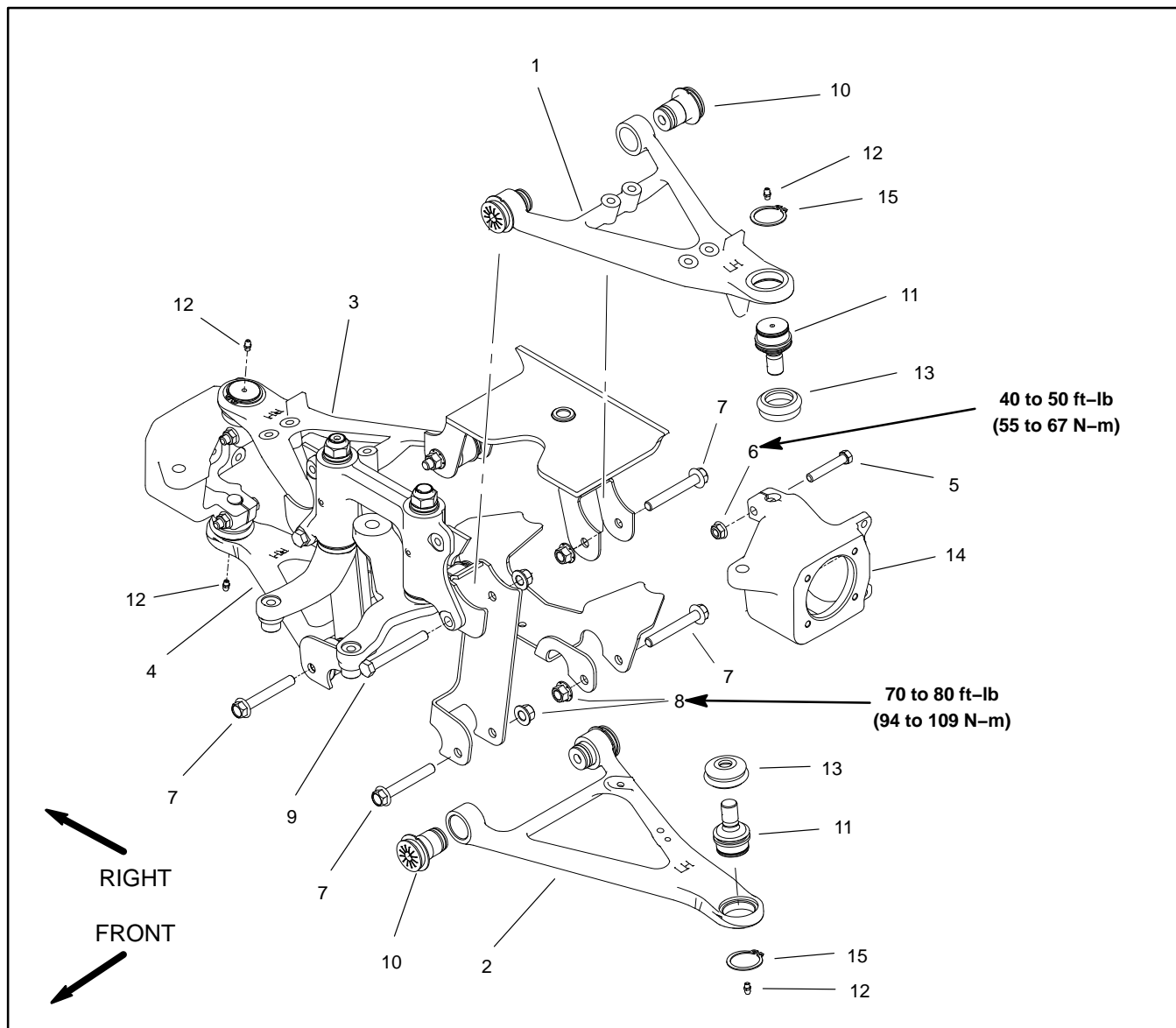
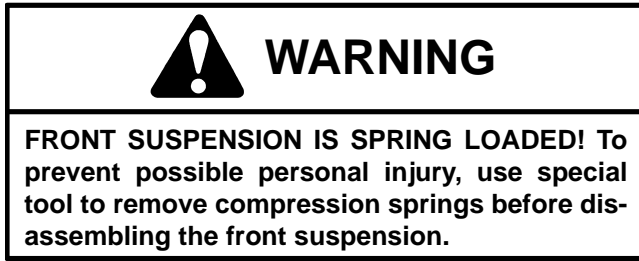

Figure 19

- |                         |                                |                        |
|-------------------------|--------------------------------|------------------------|
| 1. LH upper control arm | 6. Flange nut (4)              | 11. Ball joint         |
| 2. LH lower control arm | 7. Flange head screw (6)       | 12. Grease fitting     |
| 3. RH upper control arm | 8. Lock nut (8)                | 13. Ball joint seal    |
| 4. RH lower control arm | 9. Cap screw (2)               | 14. Knuckle (LH shown) |
| 5. Cap screw (4)        | 10. Flange bushing (2 per arm) | 15. Retaining ring     |

## Removal (Fig. 19)



1. Park vehicle on a level surface, shut engine off, remove key from ignition switch and apply parking brake.

2. If servicing upper control arm, remove front compression springs (see Front Compression Spring Service in this section).

**NOTE:** Front compression springs do not need to be removed if servicing only the lower control arm.

3. Remove cap screw and flange nut that secure affected control arm ball joint to knuckle. Separate ball joint from knuckle. Inspect ball joint seal and replace if damaged.

4. Remove control arm from vehicle frame.

5. Disassemble control arm as needed.

A. Remove retaining ring and press ball joint out of control arm.

B. Press flange bushings from control arm.

## Installation (Fig. 19)

1. Assemble control arm.

A. Press ball joint into control arm and secure with retaining ring. Make sure that grease fitting is in ball joint.

B. Lightly oil flange bushings and press bushings fully into control arm.

2. Install ball joint seal over shaft on ball joint. Edge of seal must be inserted into ball joint slot.

3. Install and secure control arm to vehicle with removed fasteners. Tighten lock nuts from **70 to 80 ft-lb (94 to 109 N-m)**.

4. Align recess in ball joint stud with hole in knuckle. Slide ball joint stud into knuckle and secure with cap screw and flange nut. Torque nut from **40 to 50 ft-lb (55 to 67 N-m)**.

5. If removed, install front compression springs (see Front Compression Spring Service in this section).

6. Grease ball joint.

# Front Compression Spring Service

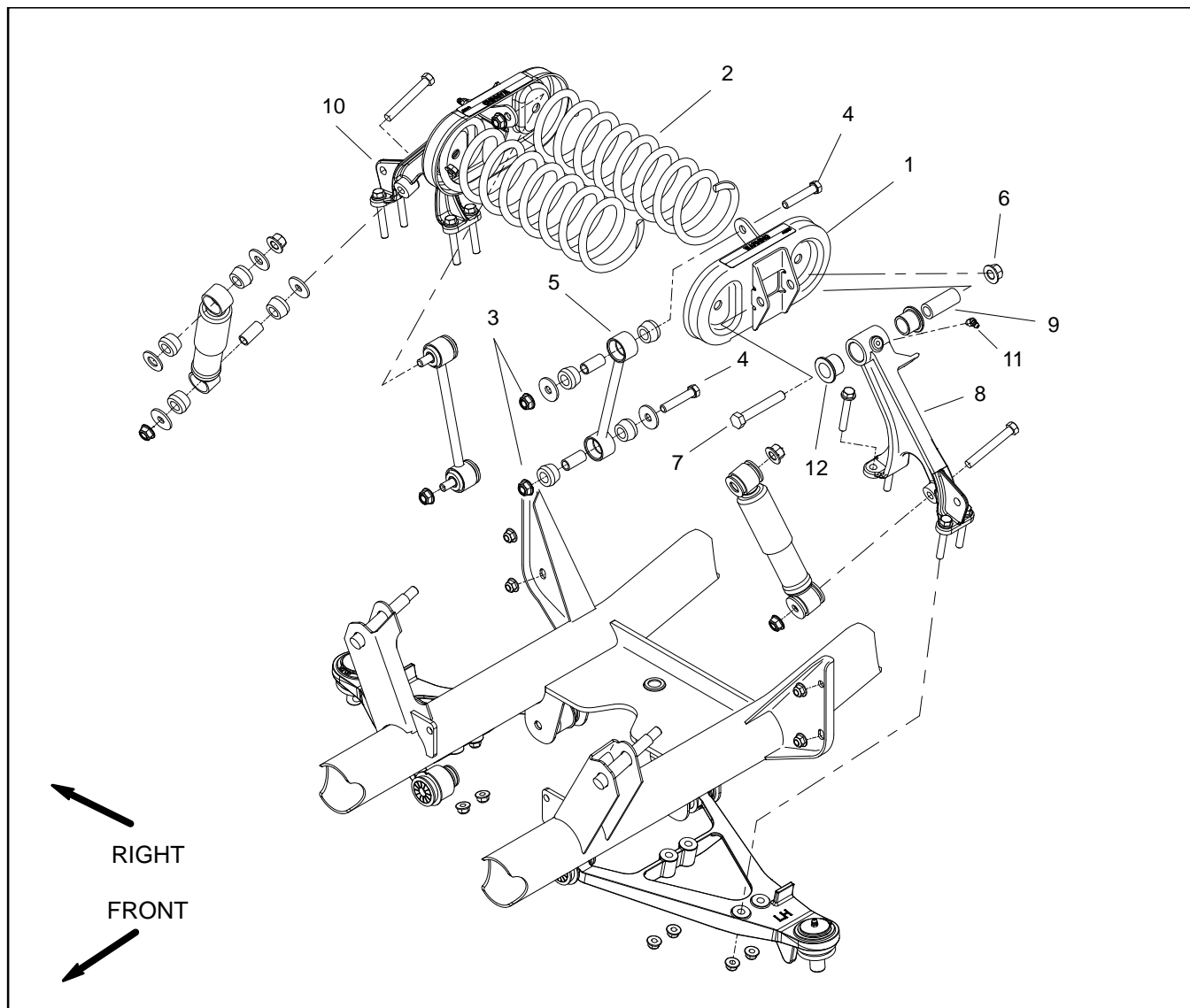

Figure 20

- |                           |                    |                          |
|---------------------------|--------------------|--------------------------|
| 1. Spring cradle (2)      | 5. Stabilizer link | 8. LH control arm tower  |
| 2. Compression spring (2) | 6. Lock nut        | 9. Spring pivot sleeve   |
| 3. Flange nut             | 7. Cap screw       | 10. RH control arm tower |
| 4. Cap screw              |                    |                          |

### Disassembly (Fig. 20)

1. Park vehicle on a level surface, shut engine off, remove key from ignition switch and apply parking brake.
2. Remove seat base to gain access to front suspension assembly (see Seat Base Removal in this section).
3. Jack up front of vehicle and secure with jack stands (see Jacking Vehicle in Chapter 1 – Safety). Remove front wheels.
4. Remove front shock absorbers (see Front Shock Absorber Removal in this section).



## WARNING

**FRONT SUSPENSION IS SPRING LOADED! To prevent possible personal injury, use compression spring tool (see Special Tools) to remove compression springs before disassembling the front suspension.**

5. Install a compression spring tool rod (see Special Tools) through holes in each spring cradle (item 1), then install nuts and washers on both ends of each rod. Tighten one nut on each rod to secure compression springs.

**NOTE:** Extended portion of each compression spring tool must be on opposite ends so cap screws that secure spring cradles to control arm towers can be removed (Fig. 22).

6. Remove flange nut and cap screw from lower end of each stabilizer link.
7. Remove lock nut and cap screw securing each spring cradle to control arm towers, then remove springs and cradles along with the stabilizer links.
8. Carefully loosen compression spring tool rods to allow disassembly of compression springs, spring cradles and stabilizer links.

### Assembly (Fig. 20)

1. Reverse the disassembly procedure to install compression springs.

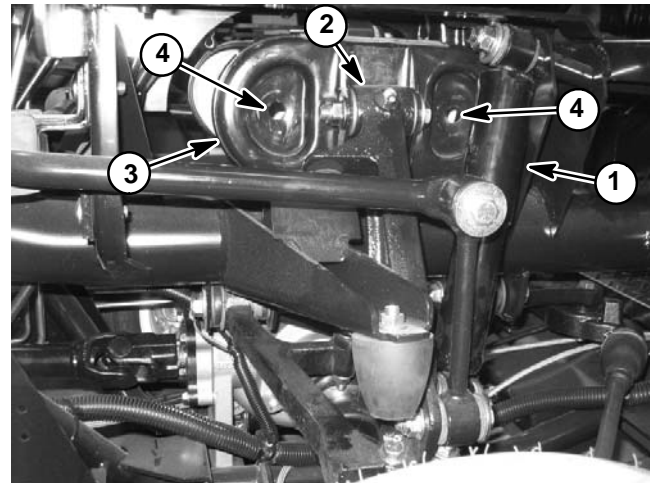

Figure 21

- |                      |                       |
|----------------------|-----------------------|
| 1. Shock absorber    | 3. Spring cradle      |
| 2. Control arm tower | 4. Spring cradle hole |

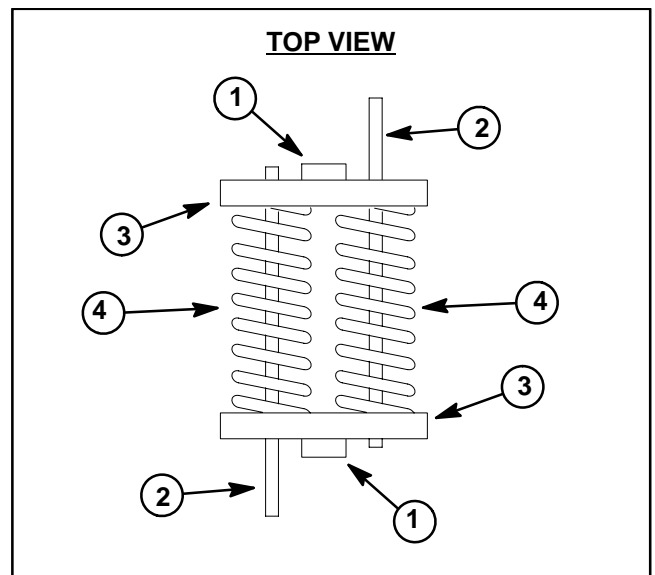

Figure 22

- |                      |                       |
|----------------------|-----------------------|
| 1. Control arm tower | 3. Spring cradle      |
| 2. Spring tool rod   | 4. Compression spring |

## Front Shock Absorber

### Removal (Figs. 23 and 24)

1. Park vehicle on a level surface, shut engine off, remove key from ignition switch and apply parking brake.
2. Remove lower and upper lock nuts, then remove shock absorber and washers. Note that washers on upper end of shock absorber are different. Washers on lower end of shock are identical.

### Installation (Figs. 23 and 24)

1. If necessary (e.g. shock absorber is being replaced or bushings are worn), insert two (2) new rubber bushings into each end of new shock absorber. Insert spacer into ram (lower) end of shock absorber.
2. Install inner washer (item 3) onto frame stud above control arm.
3. Install shock absorber with ram end down and secure upper end with outer washer (item 5) and lock nut.
4. Insert cap screw down through angled hole in control arm tower. Install washer onto cap screw and then slide shock absorber onto cap screw. Install second washer onto cap screw and secure with lock nut.

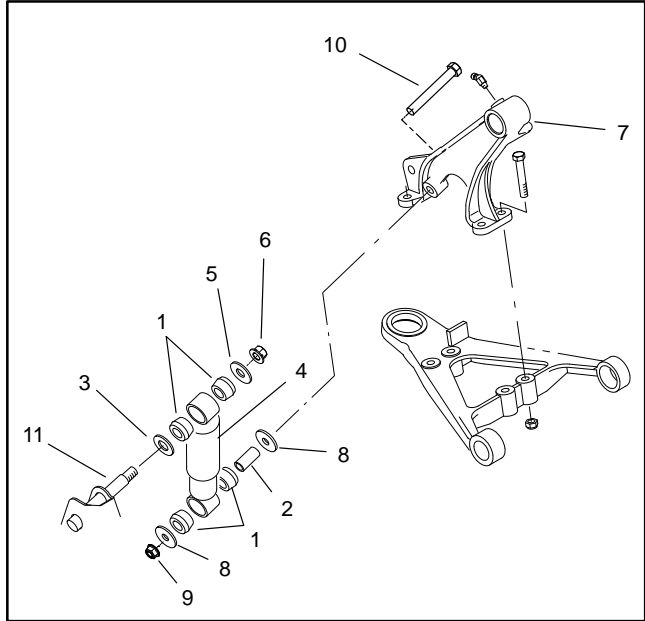

Figure 23

- |                             |                       |
|-----------------------------|-----------------------|
| 1. Rubber bushing           | 7. Control arm tower  |
| 2. Spacer                   | 8. Washer (0.445" ID) |
| 3. Inner washer (0.656" ID) | 9. Flange nut         |
| 4. Shock absorber           | 10. Cap screw         |
| 5. Outer washer (0.563" ID) | 11. Frame stud        |
| 6. Lock nut                 |                       |

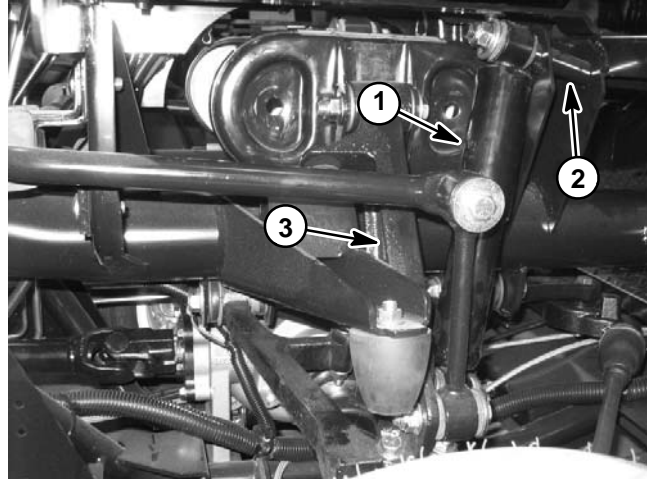

Figure 24

- |                   |                      |
|-------------------|----------------------|
| 1. Shock absorber | 3. Control arm tower |
| 2. Frame stud     |                      |

## Rear Shock Absorber

### Removal (Fig. 26)

1. Park vehicle on a level surface, shut engine off, remove key from ignition switch and apply parking brake.

**NOTE:** The three (3) flat washers used to retain shock absorber to vehicle are different. Note location of each washer during removal.

2. Remove lock nut and flat washer that secure top of shock absorber to frame.

3. Remove cap screw, flat washer and flange nut that secure bottom of shock absorber to axle.

4. Remove shock absorber and washer (item 4) from vehicle.

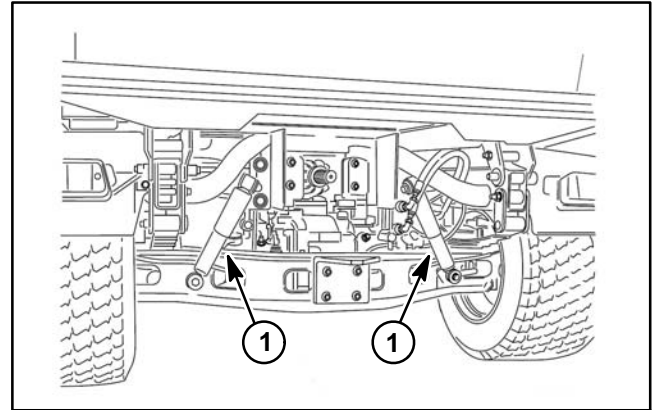

Figure 25

1. Rear shock absorber

### Installation (Fig. 26)

1. If necessary (e.g. shock absorber is being replaced or bushings are worn), insert two (2) new rubber bushings into each end of shock absorber. Insert spacer into ram (lower) end of shock absorber.

2. Install washer (item 4) onto shock absorber mounting stud on frame.

3. Slide upper end of shock absorber onto stud on frame. Install flat washer and lock nut onto stud. Tighten lock nut.

4. Place flat washer (item 7) onto cap screw. Insert cap screw through lower end of shock absorber and axle. Install flange nut onto cap screw. Torque nut from **40 to 50 ft-lb (55 to 67 N-m)**.

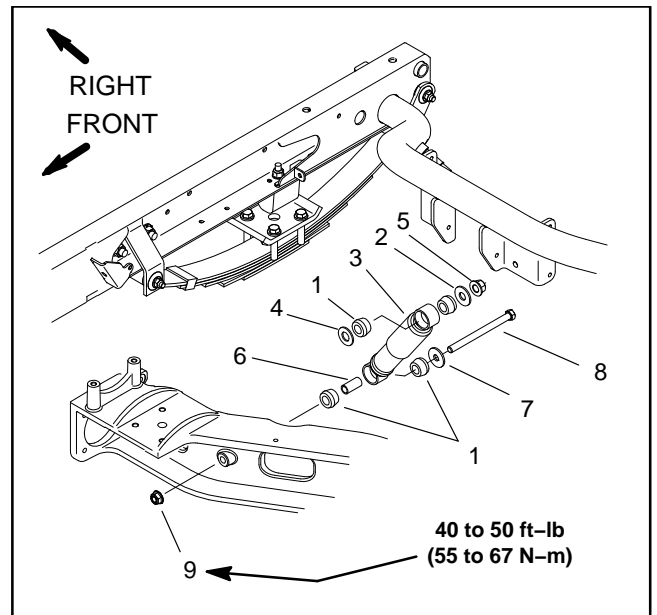

Figure 26

- |                            |                            |
|----------------------------|----------------------------|
| 1. Rubber bushing          | 6. Spacer                  |
| 2. Flat washer (0.563" ID) | 7. Flat washer (0.445" ID) |
| 3. Shock absorber          | 8. Cap screw               |
| 4. Flat washer (0.656" ID) | 9. Flange nut              |
| 5. Lock nut                |                            |

## Rear Leaf Spring

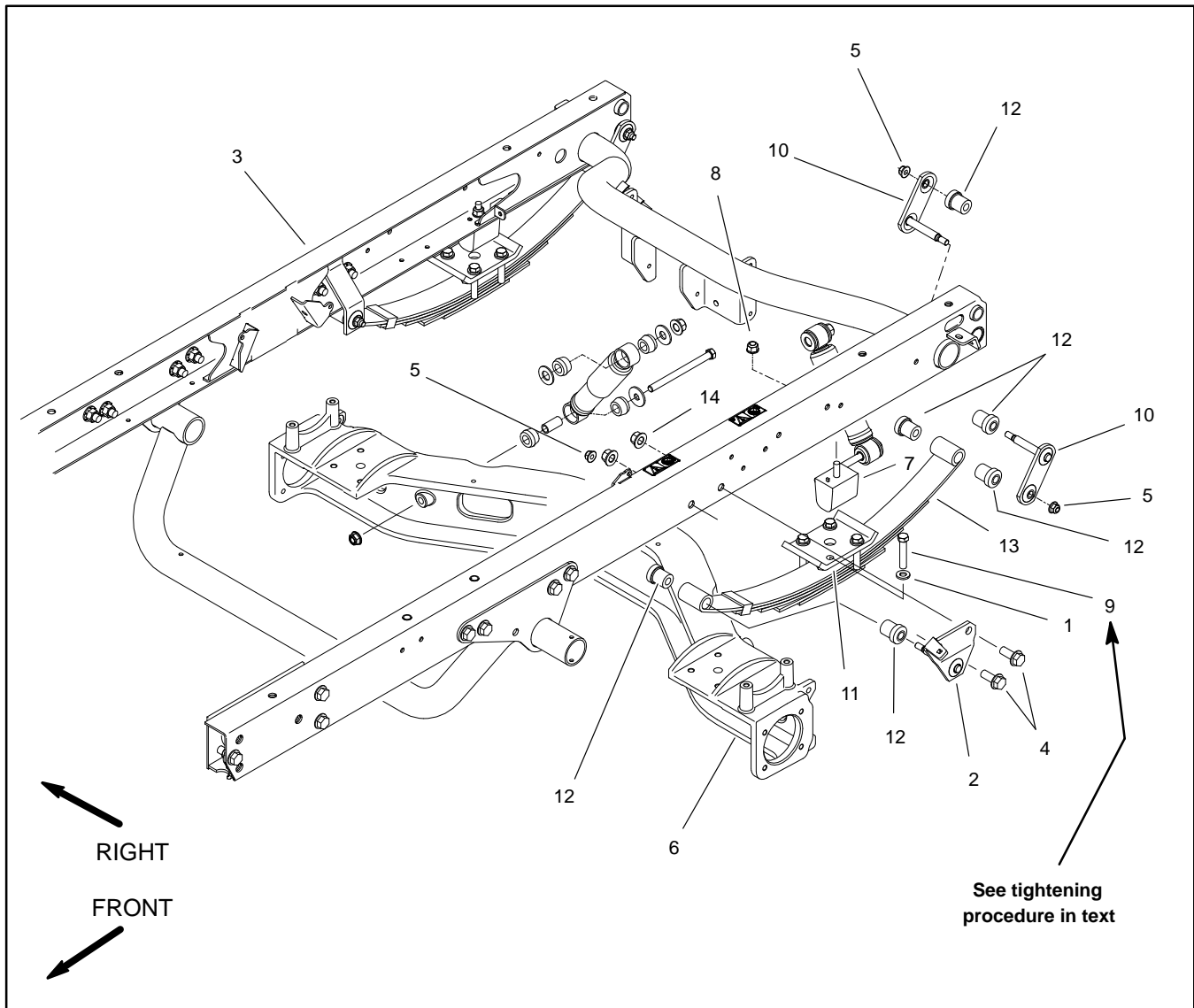

Figure 27

- |                            |                                   |                                   |
|----------------------------|-----------------------------------|-----------------------------------|
| 1. Washer (4 per plate)    | 6. Rear axle                      | 11. Spring plate (2)              |
| 2. Spring mount (LH shown) | 7. Axle bumper (2)                | 12. Rubber bushing (6 per spring) |
| 3. Rear frame              | 8. Lock nut                       | 13. Leaf spring (2)               |
| 4. Flange head screw       | 9. Bolt (4 per plate)             | 14. Lock nut                      |
| 5. Flange nut              | 10. Spring shackle (2 per spring) |                                   |

**IMPORTANT:** For proper vehicle performance, always replace the springs on both sides of the vehicle.

### Removal (Fig. 27)

1. Park vehicle on a level surface, shut engine off, remove key from ignition switch and apply parking brake.
2. Jack up and support rear of vehicle with jack stands (See Jacking Vehicle in Chapter 1 – Safety).
3. Remove rear wheels (see Wheel Assembly Removal in this section).

### Chassis

4. Support rear axle to prevent it from moving during leaf spring removal.

5. Remove four (4) bolts and washers securing leaf spring to rear axle.

6. Remove two (2) flange nuts from spring shackles. Remove spring shackles from leaf spring and frame.

7. Remove two (2) lock nuts and flange head screws securing spring mount to frame rail, then remove leaf spring assembly.



8. Remove flange nut that secures spring mount to leaf spring and remove mount from spring.

9. Remove rubber bushings from leaf spring and frame side rails.

### Installation (Fig. 27)

1. Make sure that four (4) rubber bushings are positioned in leaf spring and two (2) rubber bushings are fitted in frame side rail.

2. Insert one (1) spring shackle, from inside/out, into rear of leaf spring. Insert spring mount, from outside/in, to front of leaf spring and secure, finger tight, with flange nut.

3. Install leaf spring assembly to frame and rear axle. Secure spring mount to frame with two (2) flange head screws and lock nuts and tighten finger tight. Tighten flange nuts. Leave lock nuts that secure spring mount to frame rail finger tight.

4. Insert second spring shackle through rubber bushings in frame rail and onto spring shackle already placed in leaf spring. Install flange nuts to spring shackles and tighten finger tight.

**NOTE:** During leaf spring installation, make sure axle and spring plate are centered on leaf spring knob.

5. Install spring plate to top of leaf spring, then secure spring to axle with bolts and washers. Tighten bolts in a crossing pattern until spring plate, leaf spring and axle contact.

6. Fully tighten flange head screws and lock nuts securing spring mount to frame rail. Also, fully tighten flange nuts.

7. Tighten bolts securing spring plate and leaf spring to axle using a crossing pattern and the following torque values:

A. Tighten bolts to **25 ft-lb (33 N-m)** in a crossing pattern.

B. Tighten bolts from **50 to 60 ft-lb (67 to 81 N-m)** in a crossing pattern.

C. Retighten bolts from **50 to 60 ft-lb (67 to 81 N-m)**.

8. Install rear wheels (see Wheel Assembly Installation in this section).

9. Lower vehicle to ground. Make sure that wheel lug nuts are properly torqued from **80 to 90 ft-lb (109 to 122 N-m)**.

## Front Wheel Alignment

1. Rotate steering wheel to center the pitman arm with the vehicle to ensure correct front wheel alignment measurement.
2. With the pitman arm centered, measure center to center distance (at axle height) between the front wheels at both front and rear of the wheels (Fig. 28). The front and rear measurements should be equal with a tolerance of 0.120" (3 mm). Rotate tires and make a second measurement.
3. If measurements determine that an adjustment is needed, loosen jam nuts on front tie rod ends and rotate tie rods equally to change wheel alignment. Torque jam nuts to **45 to 55 ft-lb (61 to 74 N-m)** after adjustment is complete.
4. After alignment has been checked and/or adjusted, check for component interference as steering wheel is turned from lock to lock. If necessary, adjust tie rods equally to center steering components and then re-check front wheel alignment.
5. Make sure that all jam nuts are properly torqued.

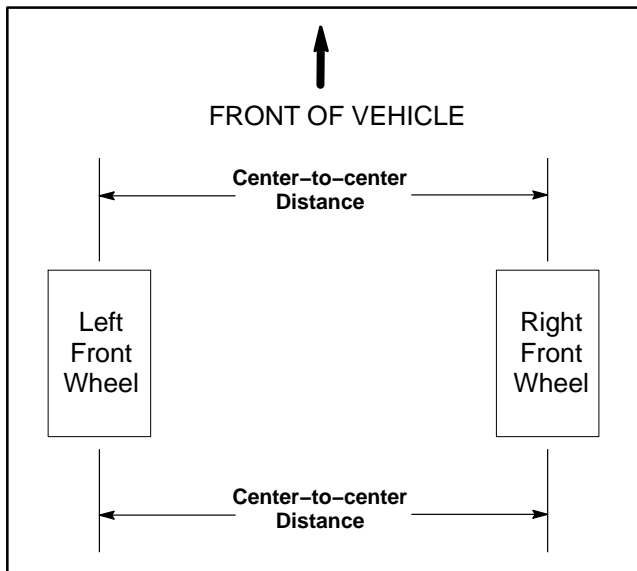

Figure 28

## Steering Wheel

### Removal (Fig. 29)

1. Park vehicle on a level surface, shut engine off, remove key from ignition switch and apply parking brake.
2. Carefully remove steering wheel cover from steering wheel.
3. Remove hex nut and flat washer that secure steering wheel to steering control valve.
4. Pull steering wheel from control valve. If necessary, use suitable puller to remove steering wheel.

### Installation (Fig. 29)

1. Apply antiseize lubricant to shaft of control valve.
2. Slide steering wheel onto control valve shaft.
3. Secure steering wheel with flat washer and hex nut. Torque hex nut from **20 to 25 ft-lb (28 to 33 N-m)**.
4. Install steering wheel cover.

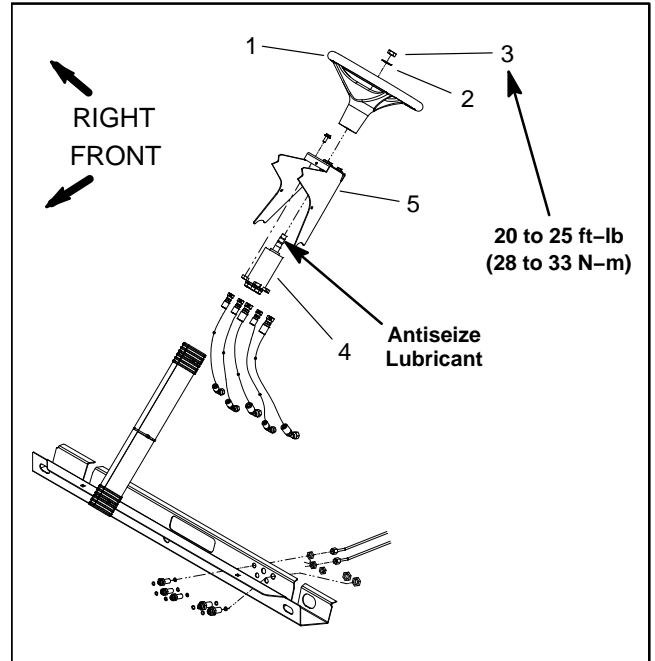

Figure 29

- |                   |                           |
|-------------------|---------------------------|
| 1. Steering wheel | 4. Steering control valve |
| 2. Flat washer    | 5. Frame                  |
| 3. Hex nut        |                           |

# Seat Base

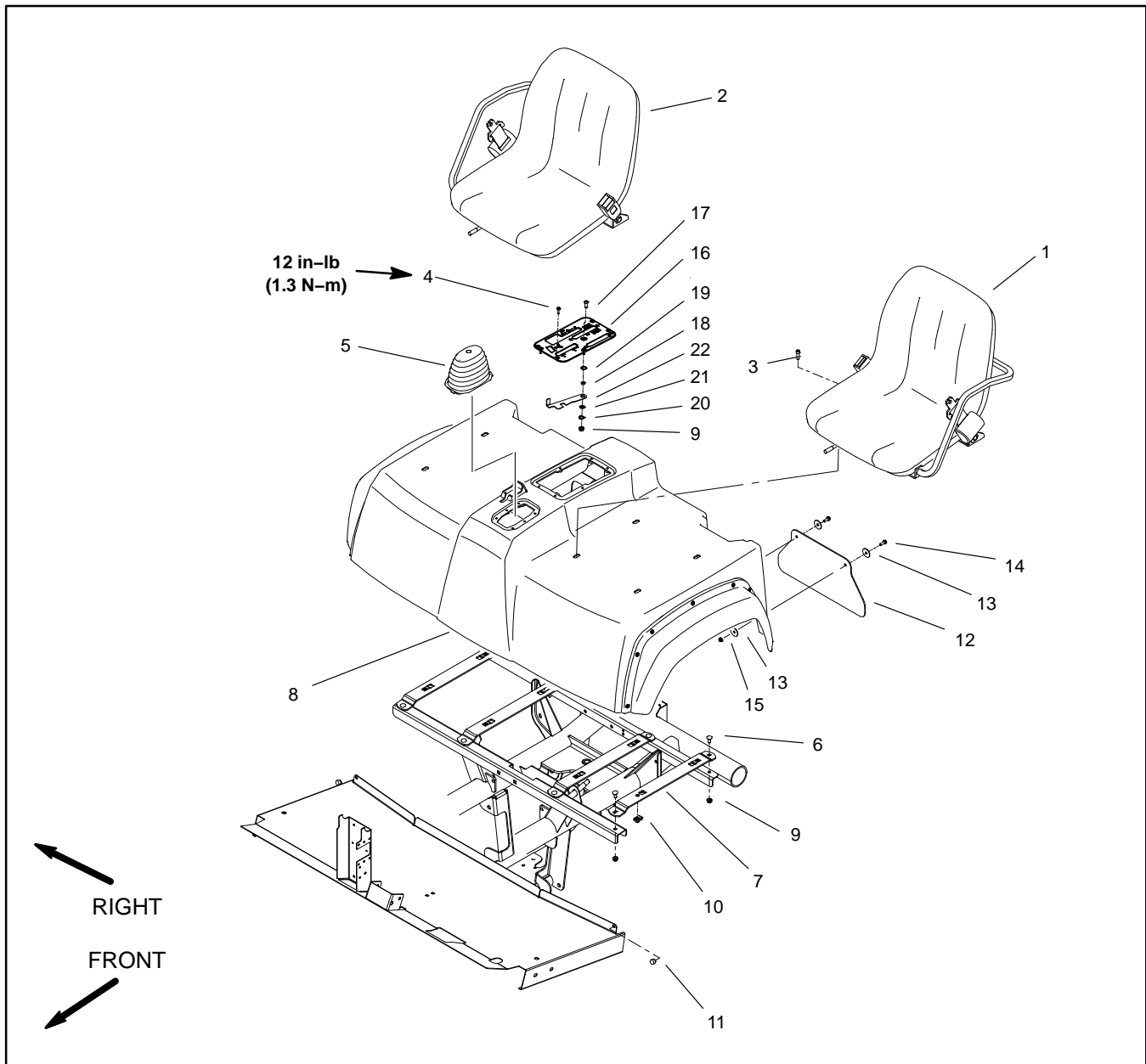

Figure 30

- |                           |                           |                       |
|---------------------------|---------------------------|-----------------------|
| 1. LH (operator) seat     | 9. Flange nut (9)         | 16. Control plate     |
| 2. RH (passenger) seat    | 10. U-clip nut (8)        | 17. Socket head screw |
| 3. Socket head screw (8)  | 11. Rubber bumper (2)     | 18. Spacer            |
| 4. Washer head screw (12) | 12. Mudflap (2)           | 19. Nylon washer      |
| 5. Shift boot             | 13. Flat washer (8)       | 20. Spring washer     |
| 6. Carriage bolt (8)      | 14. Flange head screw (4) | 21. Flat washer       |
| 7. Seat bracket (4)       | 15. Flange nut (4)        | 22. Detent lever      |
| 8. Seat base              |                           |                       |

### Removal (Fig. 30)

1. Park vehicle on a level surface, raise and support bed (if installed), shut engine off and apply the parking brake. Remove key from ignition switch.
2. Remove six (6) carriage screws and flange nuts that secure ROPS cover to ROPS frame. Remove cover from vehicle (Fig. 31).
3. Remove knobs from control levers, then remove center console control plate assembly.
4. Remove four (4) socket head screws that secure each seat to vehicle. Lift both seats from vehicle.
5. Lift engine coolant overflow tank from slots in rear of seat base. Position overflow tank away from seat base.
6. Carefully lift seat base from vehicle.

### Installation (Fig. 30)

1. Lower seat base to vehicle while guiding control levers through seat base opening.
2. Secure seats to vehicle with removed fasteners.
3. Secure engine coolant overflow tank into slots in rear of seat base.
4. Secure center console control plate to seat base with removed screws. Install knobs on control levers.
5. Install ROPS cover to vehicle (Fig. 31).

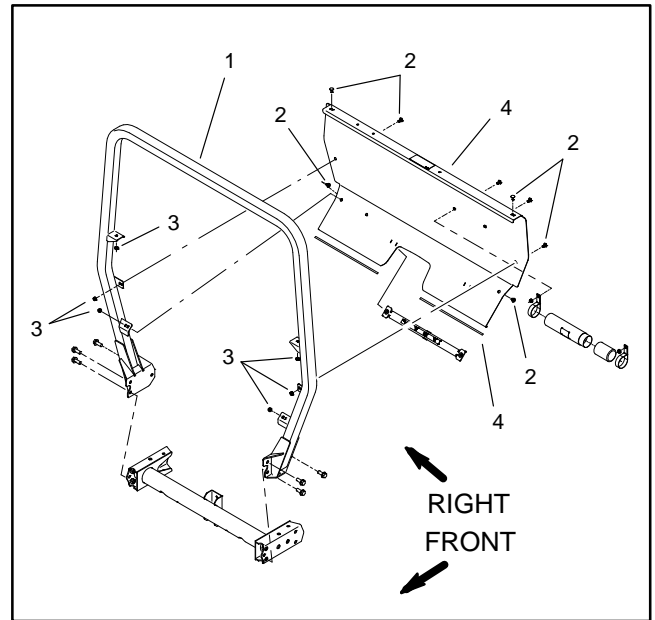

Figure 31

- |                       |               |
|-----------------------|---------------|
| 1. ROPS frame         | 4. ROPS cover |
| 2. Carriage screw (6) | 5. Seal (2)   |
| 3. Flange nut (6)     |               |

## Hood

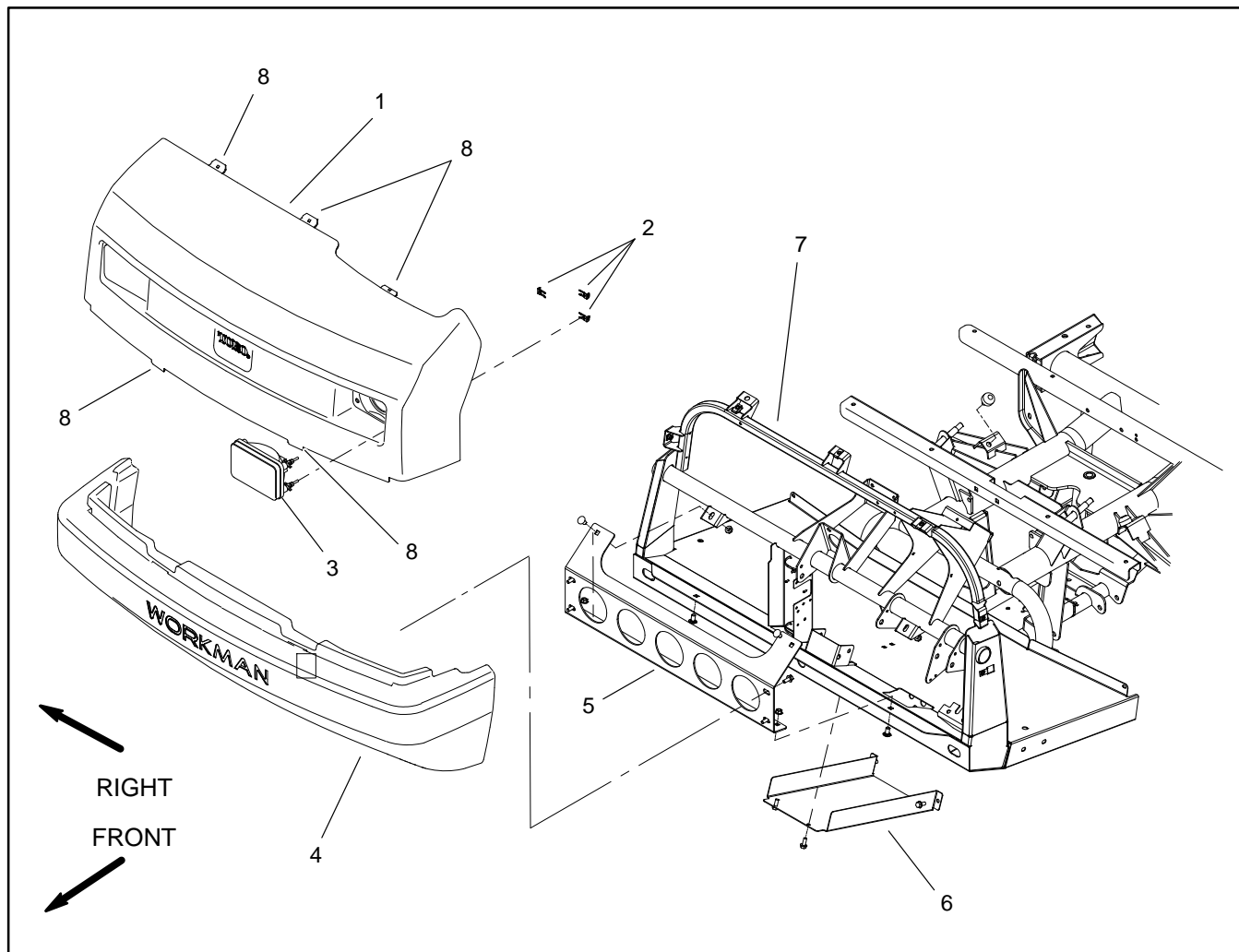

Figure 32

- 1. Hood
- 2. Clip (3 per headlight)
- 3. Headlight (2)

- 4. Bumper
- 5. Bumper bracket
- 6. Cover

- 7. Operator frame
- 8. Hood attachment tab

### Removal (Fig. 32)

1. Park vehicle on a level surface, shut engine off and apply the parking brake. Remove key from ignition switch.
2. Grasp hood at headlight openings and carefully pull hood away from operator frame.
3. Unplug the wire harness connector from the two (2) headlights.
4. Remove hood from vehicle.

### Installation (Fig. 32)

1. Position hood to operator frame.
2. Plug the wire harness connector to the two (2) headlights.
3. Secure hood to frame by pressing hood attachment tabs to dash and bumper.



# Electrical System

## Table of Contents

ELECTRICAL SCHEMATICS .....	2	Fuel Run/Stop Solenoid (Workman HDX-D) ....	21
SPECIAL TOOLS .....	2	Fuel Gauge Sender (Workman HD & HDX-D) ..	22
TROUBLESHOOTING .....	4	Fuel Pump (Workman HDX) .....	23
ELECTRICAL SYSTEM QUICK CHECKS .....	6	Fuel Pump (Workman HDX-D) .....	24
Battery Test (Open Circuit Test) .....	6	Temperature Sender	
Charging System Test .....	6	(Workman HDX and HDX-D) .....	25
Glow Plug System Test (Workman HDX-D) .....	6	Electric Fan Thermal Switch	
Verify Interlock System Operation .....	7	(Workman HDX and HDX-D) .....	26
COMPONENT TESTING .....	8	Speed Sensor (Workman HDX and HDX-D) ....	27
Ignition (Key) Switch .....	8	Glow Controller (Workman HDX-D) .....	28
Gauge Cluster .....	9	High Flow Hydraulics Kit Switch (Vehicles with	
Fuses .....	10	High Flow Hydraulics Kit) .....	29
Headlight Switch .....	11	Hydraulic Solenoid Valve Coil (Vehicles with	
Clutch Switch(s) .....	12	High Flow Hydraulics Kit) .....	30
Brake Switch(s) .....	13	Rear PTO Switch (Optional Kit) .....	31
Hydraulic Lift Lever Interlock Switch .....	14	Interlock Switch (1/3 Area Platform Kit) .....	32
3rd – High Lockout Key Switch .....	15	SERVICE AND REPAIRS .....	33
Transaxle Switches .....	16	Battery Storage .....	33
Power Relay (Four Terminals) .....	17	Battery Care .....	33
Relay (Five Terminals) .....	18	Battery Service .....	33
Fusible Link .....	19	Headlights .....	37
Diodes .....	20	Tail Lamps .....	38
Electronic Throttle Control (Workman HDX) ....	20		

# Electrical Schematics

The electrical schematics and other electrical drawings for Workman HD series vehicles are located in Chapter 11 - Electrical Drawings.

## Special Tools

Order special tools from your Toro Distributor. Some tools may also be available from a local supplier.

---

### Digital Multimeter

The digital multimeter can test electrical components and circuits for current (amps), resistance (ohms) or voltage. Obtain this tool locally.

**NOTE:** Toro recommends the use of a DIGITAL Volt-Ohm-Amp multimeter when testing electrical circuits. The high impedance (internal resistance) of a digital meter in the voltage mode will make sure that excess current is not allowed through the meter. This excess current can cause damage to circuits not designed to carry it.

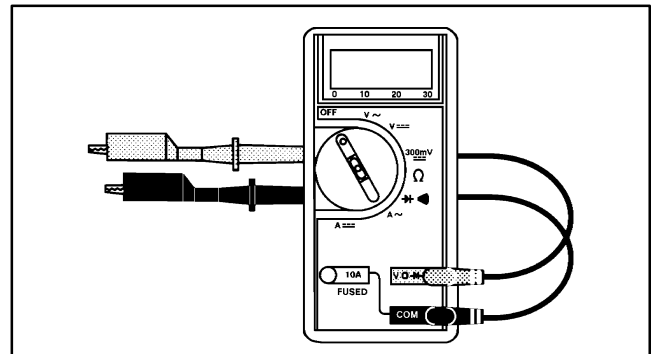

Figure 1

---

### Dielectric Gel

Dielectric gel should be used to prevent corrosion of unsealed connection terminals. To ensure complete coating of terminals, liberally apply gel to both component and wire harness connector, plug connector to component, unplug connector, reapply gel to both surfaces and reconnect harness connector to component. Connectors should be thoroughly packed with gel for effective results.

Do not use dielectric gel on sealed connection terminals as the gel can unseat connector seals during assembly.

Toro Part Number: **107-0342**



Figure 2

---

### Battery Hydrometer

Use the battery hydrometer when measuring specific gravity of battery electrolyte. Obtain this tool locally.



Figure 3



---

## Battery Terminal Protector

Aerosol spray that should be used on battery terminals, ring terminals, and fork terminals to reduce corrosion problems. Apply battery terminal protector to the connection after the battery cable, ring terminal, or fork terminal has been secured.

Toro Part Number: **107-0392**



Figure 4

# Troubleshooting



## CAUTION

Remove all jewelry, especially rings and watches, before doing any electrical troubleshooting or testing. Disconnect the battery cables unless the test requires battery voltage.

For effective troubleshooting and repairs, you must have a good understanding of the electrical circuits and components used on this vehicle (see electrical schematics and drawings in Chapter 11 – Electrical Drawings).

If the vehicle has any interlock switches by-passed, they must be reconnected for proper troubleshooting and safety.

Condition	Possible Cause
Nothing happens when start attempt is made.	<p>Clutch pedal not depressed – instruct operator.</p> <p>Hydraulic lift lever not in neutral position – instruct operator.</p> <p>Rear PTO (if equipped) engaged – instruct operator.</p> <p>1/3 Area Platform Lift (if equipped) and parking brake is engaged – instruct operator.</p> <p>Low battery charge.</p> <p>Loose or corroded battery cables. Loose or corroded ground.</p> <p>”RUN” fuse (10 amp) faulty.</p> <p>Fusible link faulty.</p> <p>Clutch proximity switch faulty.</p> <p>Clutch proximity switch wiring loose, corroded or damaged.</p> <p>Lift lever interlock switch out of adjustment or faulty.</p> <p>Lift lever interlock switch wiring loose, corroded or damaged.</p> <p>Rear PTO switch (if equipped) faulty.</p> <p>Rear PTO switch (if equipped) wiring loose, corroded or damaged.</p> <p>Faulty ignition key switch.</p> <p>Ignition switch wiring loose, corroded or damaged.</p> <p>Start relay faulty.</p> <p>Start relay wiring loose, corroded or damaged.</p> <p>Starter solenoid wiring loose, corroded or damaged.</p> <p>Starter solenoid faulty.</p>
Starter cranks, but should not, with clutch pedal released.	Clutch proximity switch faulty.

Condition	Possible Cause
Starter cranks, but should not, with hydraulic lift lever out of the neutral position.	Lift lever interlock switch out of adjustment. Lift lever interlock switch faulty.
Starter cranks, but should not, with rear PTO (if equipped) engaged.	Rear PTO switch faulty.
Starter cranks, but should not, with 1/3 Area Platform Lift (if equipped) and parking brake engaged.	Parking brake proximity switch is faulty.
Starter solenoid clicks, but starter will not crank. (If solenoid clicks, problem is not in interlock system.)	Low battery charge. Loose or corroded battery cables or ground. Loose, corroded or damaged wiring at starter. Loose starter mounting bolts. Faulty starter solenoid. Faulty starter.
Starter cranks but engine will not start.	3rd–High lockout key switch in Slow position with transaxle in 3rd gear and High range – instruct operator. 10 amp fuse is faulty. Engine or fuel system problem (see appropriate Engine chapter).
Engine does not shut off immediately when ignition key switch is turned off (Workman HD only).	Damaged or disconnected wiring for kill relay. Kill relay faulty.
Engine runs, but should not, with 3rd–High lockout switch in Slow position and transaxle in 3rd gear and High range.	3rd–High lockout key switch faulty. 3 <sup>rd</sup> gear lockout switch on transaxle faulty. High–Low lockout switch on transaxle faulty.
Engine kills when shifted to 3rd gear.	3rd–High lockout key switch in Slow position with transaxle in High range – instruct operator. Damaged or disconnected wiring for 3rd–High lockout key switch. Damaged or disconnected wiring for 2–3 lockout switch or High–Low switch on transaxle.
Battery does not charge.	Alternator drive belt loose or damaged. Loose or broken wire(s). Fusible link faulty. Battery faulty. Alternator faulty.

# Electrical System Quick Checks

## Battery Test (Open Circuit Test)

Use a multimeter to measure the voltage between the battery terminals.

Set the multimeter to the DC volts setting. The battery should be at a temperature of 60F to 100F (16C to 38C). The ignition key should be in the OFF position and all accessories turned off. Connect the positive (+) meter lead to the positive battery post and the negative (-) meter lead to the negative battery post.

**NOTE:** This test provides a relative condition of the battery. Load testing of the battery will provide additional and more accurate information (see Battery Service in this Chapter).

Voltage Measured	Battery Charge Level
12.68 v (or higher)	Fully charged (100%)
12.45V	75% charged
12.24V	50% charged
12.06V	25% charged
11.89V	0% charged

## Charging System Test

This is a simple test used to determine if a charging system is functioning. It will tell you if a charging system has an output, but not its capacity.

Use a multimeter set to the DC volts setting. Connect the positive (+) meter lead to the positive battery post and the negative (-) meter lead to the negative battery post. Leave the test leads connected and record the battery voltage.

**NOTE:** Upon starting the engine, the battery voltage will drop and then should increase once the engine is running.

**NOTE:** Depending upon the condition of the battery charge and battery temperature, the charging system voltage will increase at different rates as the battery charges.

Start the engine and run at high idle. Allow the battery to charge for at least three (3) minutes. Record the battery voltage.

An example of a charging system that is functioning:

At least 0.50 volt over initial battery voltage.	
Initial Battery Voltage	= 12.30V
Battery Voltage after 3 Minute Charge	= 12.85V
Difference	= +0.55V

## Glow Plug System Test (Workman HDX-D)

This is a fast, simple test that can help to determine the integrity and operation of your Workman HDX-D glow plug system. The test should be run anytime hard starting (cold engine) is encountered on a diesel engine equipped with a glow plug system.

Tool(s) required: Digital multimeter and/or inductive Ammeter (AC/DC Current Transducer).

Properly connect the ammeter to the digital multimeter (refer to manufacturers' instructions) and set the multimeter to the correct scale. With the ignition switch in the

OFF position, place the ammeter pickup around the main glow plug power supply wire and read the meter prior to activating the glow plug system. Adjust the meter to read zero (if applicable). Activate the glow plug system by turning the ignition switch to ON and record the multimeter results.

The Workman HDX-D glow plug system should have a reading of approximately nine (9) amps per glow plug (27 amps total). If low current reading is observed, one (or more) of the glow plugs is faulty.

---

## Verify Interlock System Operation

The purpose of the interlock system is to prevent the engine from cranking or starting unless the clutch pedal is depressed (all models), the hydraulic lift lever is in the neutral position (all models) and rear PTO (if equipped) is disengaged.

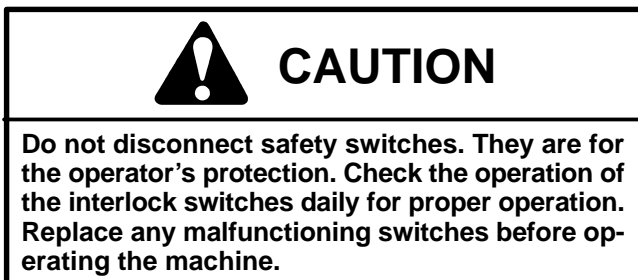

### To verify clutch interlock switch operation:

1. Sit on operator's seat and engage parking brake. Move shift lever to NEUTRAL position. Make sure that hydraulic lift lever is in neutral position. Disengage rear PTO (if equipped).
2. Without depressing clutch pedal, rotate ignition key to START position.
3. If engine cranks or starts, there is a malfunction in the interlock system that must be repaired before operating vehicle.

### To verify operation of hydraulic lift lever interlock switch:

1. Sit on operator's seat and engage parking brake. Move shift lever to NEUTRAL position. Disengage rear PTO (if equipped).
2. Move hydraulic lift lever out of neutral position.
3. Depress clutch pedal and rotate ignition key to START position.
4. If engine cranks or starts, there is a malfunction in the interlock system that must be repaired before operating vehicle.

### To verify rear PTO interlock switch (if equipped) operation:

1. Sit on operator's seat and engage parking brake. Move shift lever to NEUTRAL position. Make sure that hydraulic lift lever is in neutral position.
2. Engage rear PTO.
3. Depress clutch pedal and rotate ignition key to START position.
4. If engine cranks or starts, there is a malfunction in the interlock system that must be repaired before operating vehicle.

# Component Testing

This section will define electrical component operation and supply test procedures that can be performed on those components.

For accurate resistance and/or continuity checks, electrically disconnect the component being tested from the circuit (e.g. unplug the clutch switch connector before doing a continuity check on the switch).

**NOTE:** Electrical troubleshooting of any 12 volt power connection can also be performed through voltage drop tests without disconnecting the component.



## CAUTION

**When testing electrical components for continuity with a digital multimeter, make sure that power to the circuit has been disconnected.**

## Ignition (Key) Switch

The ignition (key) switch has three positions (OFF, ON and START). The ignition switch is located on the dash (Fig. 6).

### Testing

The switch terminals are identified as shown (Fig. 7). The circuit wiring of the ignition switch is shown in the chart below. With the use of a multimeter (ohms setting), the switch functions may be tested to determine whether continuity exists between the various switch terminals for each switch position. Disconnect wire harness connector from key switch and verify continuity between switch terminals.

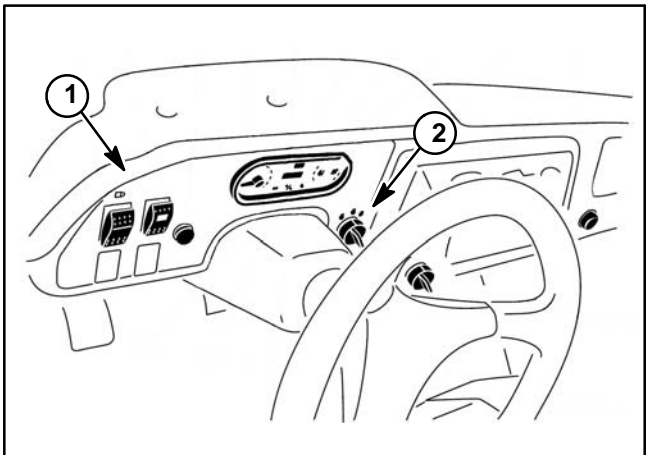

Figure 6

- 1. Dash
- 2. Ignition switch

POSITION	CIRCUITS
OFF	NONE
ON	B + C + F, D + E
START	A + B + C

After testing is completed, connect wire harness connector to ignition switch.

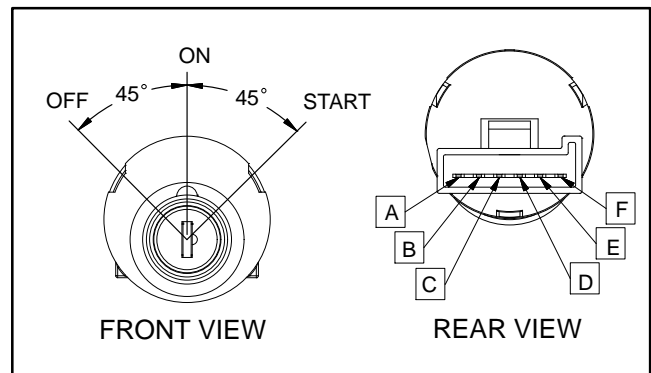

Figure 7

## Gauge Cluster

### Hourmeter

The hourmeter should move 1/10 of an hour for every six minutes that the ignition switch is in the ON position.

### Fuel Level Gauge

The fuel level gauge displays the approximate amount of fuel remaining in the fuel tank. Additionally, a red LED will illuminate when the fuel tank is low and the LED will flash when the tank is near empty.

### Oil Pressure Warning Light

The oil pressure LED should come on when the ignition key switch is in the ON position with the engine not running or if the engine oil pressure switch closes during engine operation due to low oil pressure.

### Charge Indicator Light

The charge indicator LED should come on when the ignition key switch is in the ON position with the engine not running or if the charging circuit is not operating properly during engine operation.

### Speedometer (Workman HDX and HDX-D)

The speedometer on Workman HDX and HDX-D vehicles displays the vehicle ground speed. Speed is shown in either miles per hour or kilometers per hour depending on the status of the MPH/KPH shunt.

**NOTE:** The speedometer is optional on Workman HD vehicles.

### Engine Coolant Temperature Gauge (Workman HDX and HDX-D)

The temperature gauge on Workman HDX and HDX-D vehicles displays the engine coolant temperature. If the coolant temperature exceeds 230F (110C), the temperature gauge will display a blinking red LED.

### Tachometer (Workman HDX and HDX-D)

The tachometer on Workman HDX and HDX-D vehicles displays the engine speed.

**NOTE:** The tachometer is optional on Workman HD vehicles.

### Glow Light (Workman HDX-D)

The glow light LED on Workman HDX-D vehicles illuminates whenever the engine glow plugs are energized.

### Check Engine Light (Workman HDX)

If the engine ECU identifies that an engine problem exists, the check engine light will illuminate. The engine speed may be reduced or the engine might stop. The Kubota Gasoline Service Tool (KGST) and software, and the Kubota Diagnostic Manual should be used to provide assistance in identifying the cause of the problem and any repairs that are necessary. Connect the Kubota Gasoline Service Tool (KGST) to the diagnostic connector above the engine ECU. Contact your Toro distributor for assistance in Kubota engine troubleshooting.

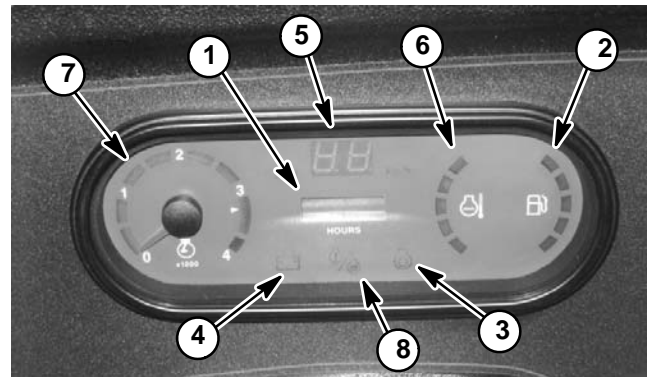

Figure 8

- |                       |                                 |
|-----------------------|---------------------------------|
| 1. Hourmeter          | 6. Temperature gauge            |
| 2. Fuel level gauge   | 7. Tachometer                   |
| 3. Oil pressure light | 8. Glow plug/Check engine light |
| 4. Charging light     |                                 |
| 5. Speedometer        |                                 |

## Fuses

The fuse blocks are located below the center of the dash panel.

### Identification and Function (Fig. 9)

Top Row LH: Protects ignition power supply.

Top Row RH: Protects power supply for light system (headlights, running lights and brake lights).

Second Row LH: Protects main (switched) power supply.

Second Row RH: Protects power supply for hazard lights (if equipped).

Third Row LH: Protects power supply for engine fuel system.

Third Row RH: Optional kit.

Fourth Row LH: Protects power supply for power point and horn (if equipped).

Fourth Row RH: Protects power supply for 4WD differential (vehicles with 4WD).

On Workman HDX and HDX-D vehicles, an additional 30 amp fuse is located in a fuse holder near the cooling fan. This fuse protects the power supply for the radiator fan.

### Fuse Testing

1. Make sure that ignition switch is OFF and key is removed from switch.
2. Remove fuse from fuse block for testing.
3. Fuse should have continuity across the terminals.

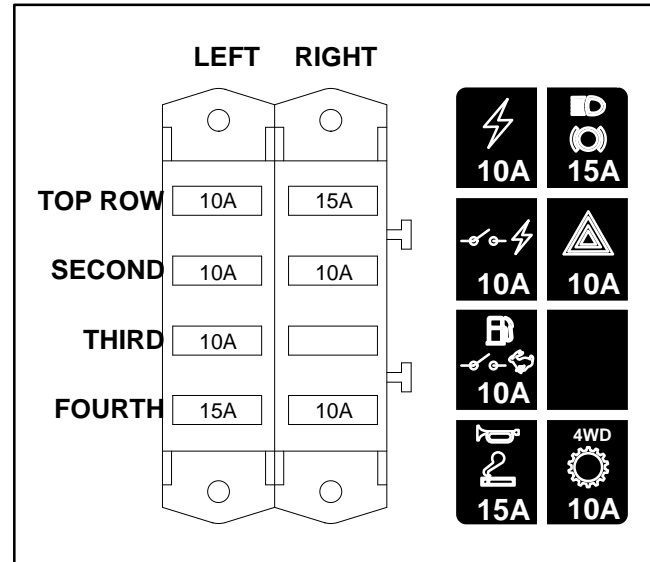

Figure 9



## Headlight Switch

This headlight switch allows the headlights to be turned on and off and is located on the dash (Fig. 10).

### Testing

The headlight switch terminals are marked as shown (Fig. 11). The circuitry of the headlight switch is shown in the chart below. With the use of a multimeter (ohms setting), the switch functions may be tested to determine whether continuity exists between the various terminals for each switch position. Disconnect wire harness connector from headlight switch and verify continuity between switch terminals for each switch position.

SWITCH POSITION	NORMAL CIRCUITS	OTHER CIRCUITS
ON	2 + 3	5 + 6
OFF	1 + 2	4 + 5

After testing is completed, connect wire harness connector to headlight switch.

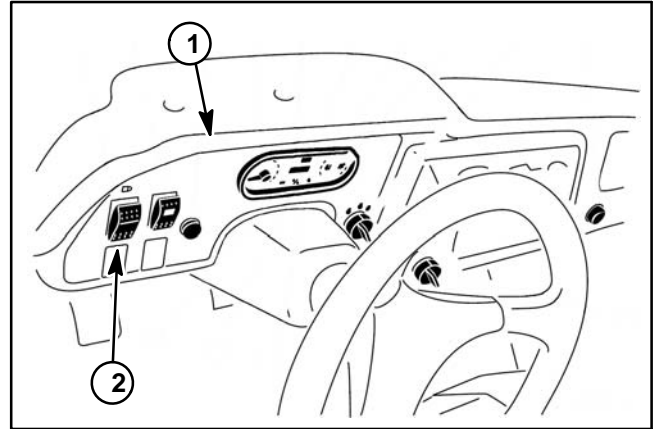

Figure 10

1. Dash

2. Headlight switch

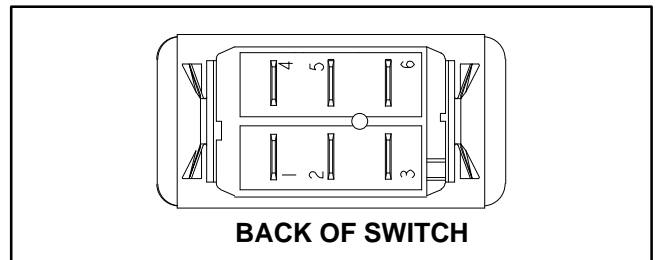

Figure 11

## Clutch Switch(s)

A proximity switch is attached to the frame under the dash of all units (Fig. 12). The switch is in its normal open position as long as the clutch pedal is released (clutch engaged). When the clutch pedal is depressed (clutch disengaged), the pedal is positioned close to the clutch switch causing the switch to close. The closed clutch switch is used in the starting interlock system to make sure that the drive system is disengaged during engine starting.

An additional switch is attached to the frame under the dash of 4WD units only (Fig. 12). The terminals of this switch are closed when the clutch pedal is released (clutch engaged – clutch pedal depressing switch plunger). In this position current is allowed to pass through the switch to energize the 4WD relay. When the clutch pedal is depressed (clutch disengaged – clutch pedal not contacting the switch plunger) the terminals switch to the normally open state, and the current path to the relay is broken.

### Testing

1. Park vehicle on a level surface, shut engine off, remove key from ignition switch and apply parking brake. Locate the clutch switch (Fig. 12).
2. Remove hood (see Hood Removal in Chapter 7 – Chassis).
3. Use a multimeter (ohms setting) to test continuity across the switch terminals.

All Units: Disconnect the wire harness connector from clutch proximity switch. Check continuity across the two (2) switch terminals. There **should be** continuity (zero ohms) when the clutch pedal is depressed and there **should not be** continuity (infinite ohms) when the clutch pedal is released.

4WD Units: Disconnect the wire harness connector from clutch switch. Check continuity across the two (2) switch terminals. There **should not be** continuity (infinite ohms) when the clutch pedal is depressed and there **should be** continuity (zero ohms) when the clutch pedal is released.

4. After switch testing is completed, connect the wire harness connector(s) to the switch(s).
5. Install hood (see Hood Installation in Chapter 7 – Chassis).

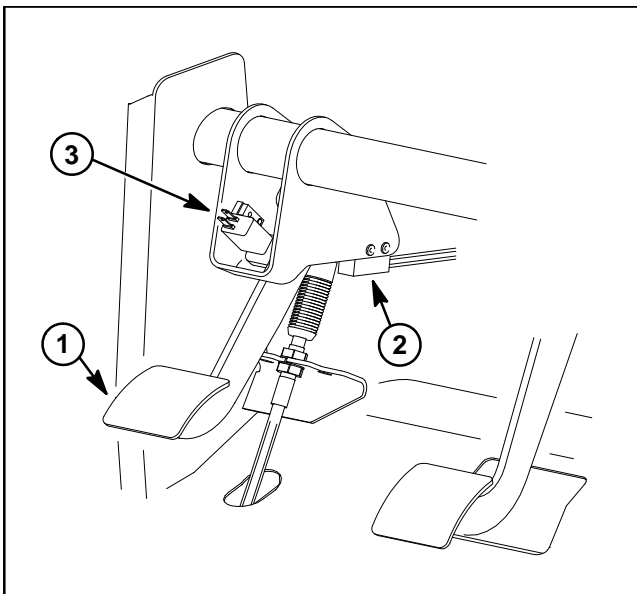

Figure 12

1. Clutch pedal
2. Clutch proximity switch (all units)
3. Clutch switch (4WD units only)

## Brake Switch(s)

The brake switch is attached to the frame under the dash (Fig. 13). A switch with one set of normally closed terminals is used on 2WD units. A switch with one set of normally closed terminals and one set of normally open terminals is used on 4WD units (Fig. 14).

When the brakes are not applied, the brake pedal presses the brake switch plunger to open the normally closed terminals. When the brakes are applied, the pedal moves away from the brake switch plunger, the terminals switch to the normally closed state, and a current path to illuminate the stop lights is made.

The additional normally open terminals of the brake switch used in 4WD units are closed when the brakes are not applied. In this position current is allowed to pass through the switch to energize the 4WD relay. When the brakes are applied, the pedal moves away from the brake switch plunger, the terminals switch to the normally open state, and the current path to the relay is broken.

### Testing

1. Park vehicle on a level surface, shut engine off, remove key from ignition switch and apply parking brake. Locate the brake switch (Fig. 13).
2. Disconnect the wire harness connector from the brake switch.
3. Use a multimeter (ohms setting) to test continuity across the switch terminals.

**2WD UNITS:** Test continuity across the two (2) switch terminals. There **should be** continuity (zero ohms) when the brake pedal is depressed and there **should not be** continuity (infinite ohms) when the brake pedal is released.

**4WD UNITS:** Test continuity across the two (2) normally closed switch terminals (Fig. 14). There **should be** continuity (zero ohms) when the brake pedal is depressed and there **should not be** continuity (infinite ohms) when the brake pedal is released.

Test continuity across the two (2) normally open switch terminals (Fig. 14). There **should not be** continuity (infinite ohms) when the brake pedal is depressed and there **should be** continuity (zero ohms) when the brake pedal is released.

4. After switch testing is completed, connect the wire harness connector to the brake switch.

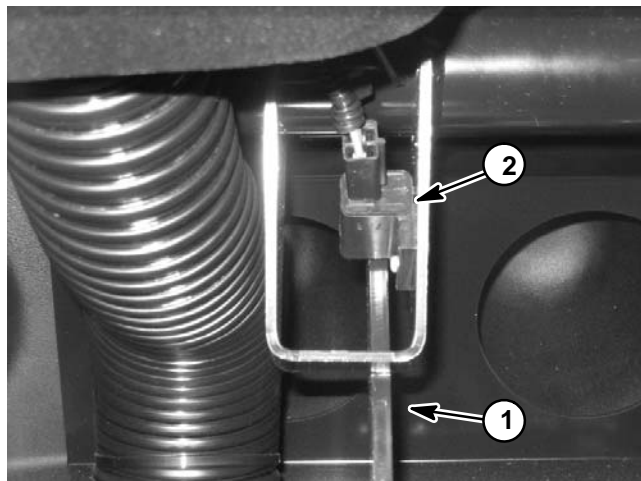

Figure 13

1. Brake pedal
2. Brake switch (2WD units)

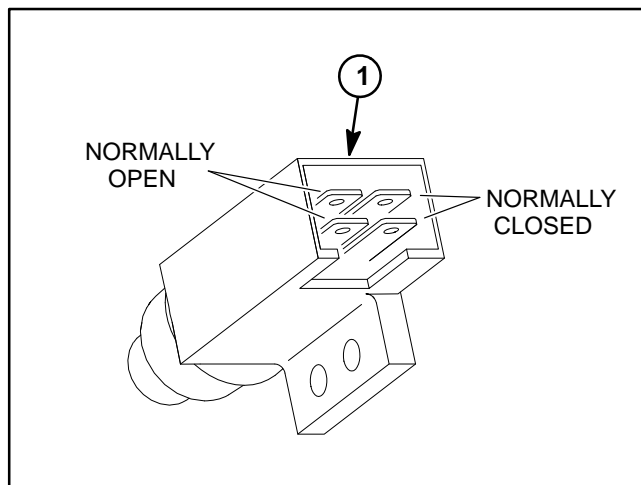

Figure 14

1. Brake switch (4WD units)

## Hydraulic Lift Lever Interlock Switch

The lift lever interlock switch is a normally open proximity switch that is attached to the control lever support (Fig. 15). The interlock switch is in its normal open position whenever the hydraulic lift lever is moved away from the neutral position. When the lift lever is in the neutral position, the lift lever linkage is positioned close to the interlock switch causing the switch to close. The lift lever interlock switch is used in the starting system to make sure that the hydraulic lift circuit is disengaged during engine starting.

### Testing

1. Park vehicle on a level surface, shut engine off, remove key from ignition switch and apply parking brake.
2. Remove knobs from control levers, then remove control plate assembly from seat base (Fig. 16).
3. Locate the lift lever interlock switch (Fig. 15).
4. Disconnect the wire harness connector from the lift lever interlock switch.
5. With the use of a multimeter (ohms setting), test for continuity across the two (2) switch terminals. There **should be** continuity (zero ohms) when the lift lever is in the neutral position and there **should not be** continuity (infinite ohms) when the lift lever is out of the neutral position.
6. After switch testing is completed, connect the wire harness connector to the lift lever interlock switch. Secure panel to seat base.
7. Secure center console control plate to seat base with removed screws. Install knobs on control levers.

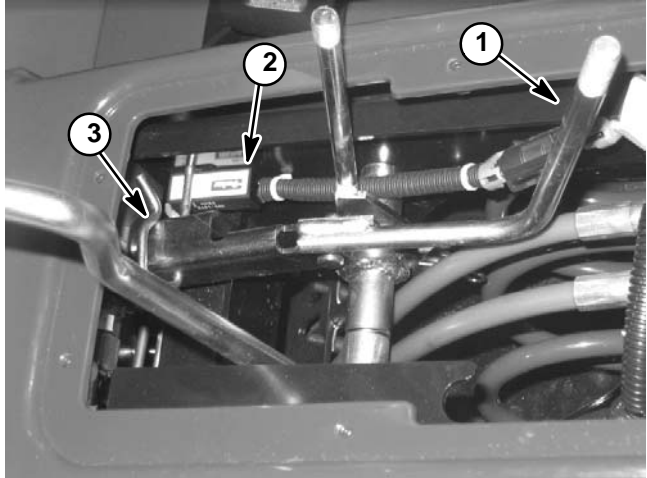

Figure 15

1. Lift lever
2. Interlock switch
3. Retainer pin

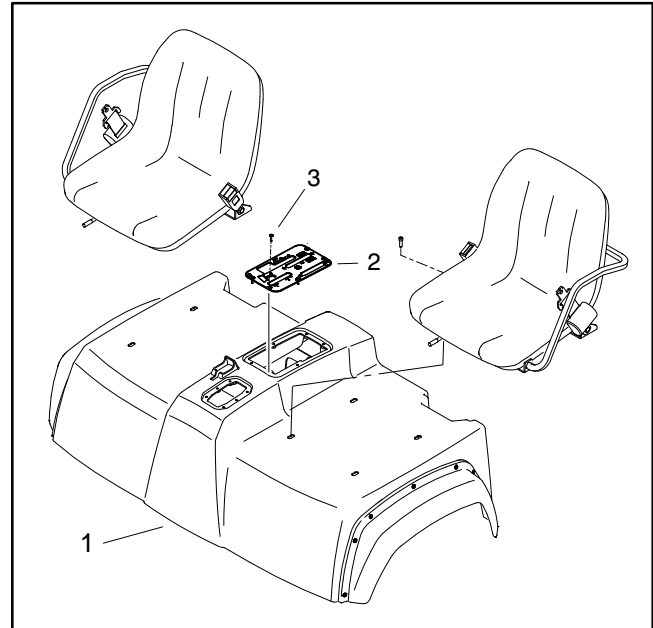

Figure 16

1. Seat base
2. Control plate
3. Screw (6)

### 3rd – High Lockout Key Switch

The 3rd – High lockout key switch has two positions: SLOW (turtle) and FAST (rabbit). This switch is located on the dash (Fig. 17).

#### Testing

The switch terminals are identified (Fig. 18). The circuit wiring of the switch is shown in the chart below. With the use of a multimeter (ohms setting), the switch functions may be tested to determine whether continuity exists between the various switch terminals for each switch position. Disconnect wire harness connector from 3rd – High lockout key switch and verify continuity between switch terminals.

**NOTE:** Switch terminals B and C are not used on Workman HD series vehicles.

POSITION	CIRCUITS
SLOW	B + C
FAST	B + C, A + D

After testing is completed, connect wire harness connector to the 3rd – High lockout key switch.

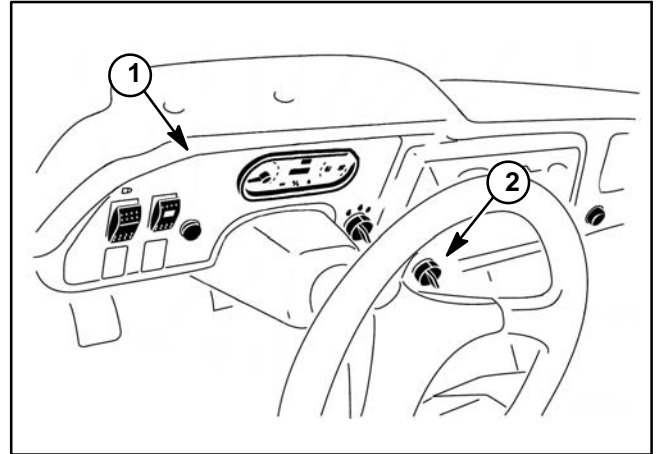

Figure 17

1. Dash

2. 3rd-High key switch

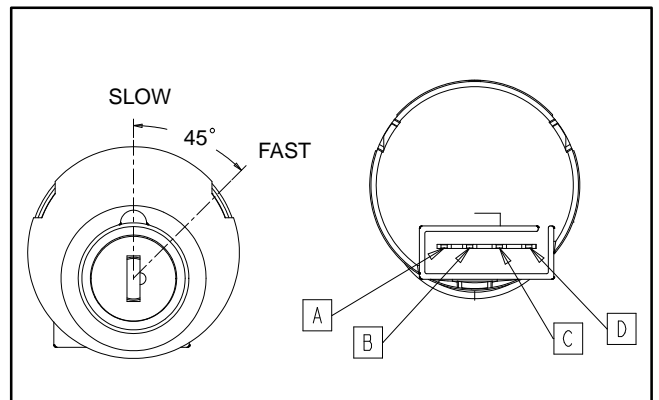

Figure 18

## Transaxle Switches

### 3<sup>rd</sup> Gear Lockout Switch

The transaxle 2–3 Lockout switch is located on the top of the transaxle (Fig. 19). The switch is closed in 1<sup>st</sup> and 2nd gear and open in 3rd gear.

To test the switch, disconnect the wire harness connector from the switch. Use a multimeter (ohms setting) to test for continuity across the two (2) switch terminals. With the engine off and the transaxle shifter in 1<sup>st</sup> or 2nd gear, there **should be** continuity (zero ohms). Move shifter to 3rd gear and there **should not be** continuity (infinite ohms). After testing, connect wire harness connector to switch.

### High–Low Lockout Switch

The transaxle High–Low Lockout switch is located on the front of the transaxle (Fig. 19). The switch is closed in Low range and open in High range.

To test the switch, disconnect the wire harness connector from the switch. Use a multimeter (ohms setting) to test for continuity across the two (2) switch terminals. With the engine off and the shift lever in LOW range, there **should be** continuity (zero ohms). Move shift lever to HIGH range and there **should not be** continuity (infinite ohms). After testing, connect wire harness connector to switch.

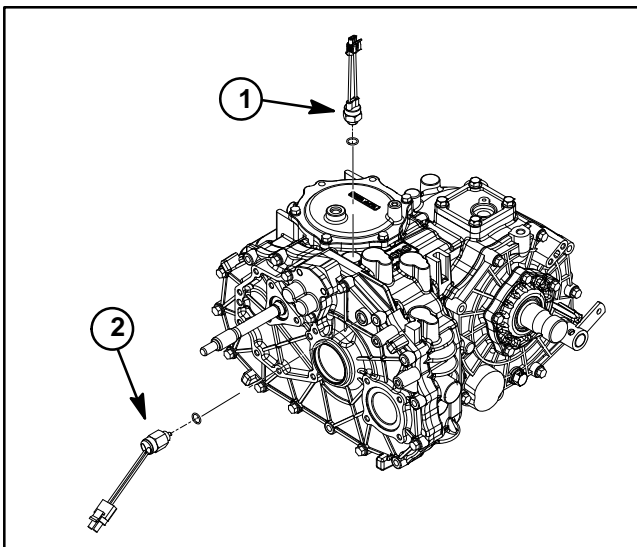

Figure 19

1. 2–3 lockout switch

2. Hi–Low lockout switch

## Power Relay (Four Terminals)

The main power relay is used to provide electrical power to the majority of the Workman circuits. When the ignition key is in either the ON or START position, the main power relay is energized. The main power relay is attached to the relay bracket under the right side of the bed near the rear axle (Fig. 20).

In addition to the main power relay, Workman HDX–D vehicles (diesel engine) use a four terminal relay to supply electrical power to the glow plugs (glow relay). The glow plug controller determines when the glow relay is energized. The glow relay is attached to the relay bracket (Fig. 20).

### Testing

1. Park machine on a level surface, raise bed, stop engine, apply parking brake and remove key from ignition switch.
2. Install bed support on bed lift cylinder to prevent bed from lowering.
3. Locate relay to be tested and disconnect the machine wire harness connector from the relay. Remove relay from machine for easier testing.

**NOTE:** Prior to taking small resistance readings with a digital multimeter, short the meter test leads together. The meter will display a small resistance value (usually 0.5 ohms or less). This resistance is due to the internal resistance of the meter and test leads. Subtract this value from the measured value of the component you are testing.

4. Verify coil resistance between terminals 85 and 86 with a multimeter (ohms setting) (Fig. 21). Resistance should be approximately 72 ohms.
5. Connect multimeter (ohms setting) leads to relay terminals 30 and 87. Ground terminal 86 and apply +12 VDC to terminal 85. The relay should have continuity between terminals 30 and 87 when +12 VDC is applied to terminal 85. The relay should not have continuity between terminals 30 and 87 when +12 VDC is removed from terminal 85.
6. Replace relay if testing determines that relay is faulty.
7. After testing is complete, install relay to relay bracket and connect wire harness connector to relay.
8. Remove bed support from lift cylinder and lower bed.

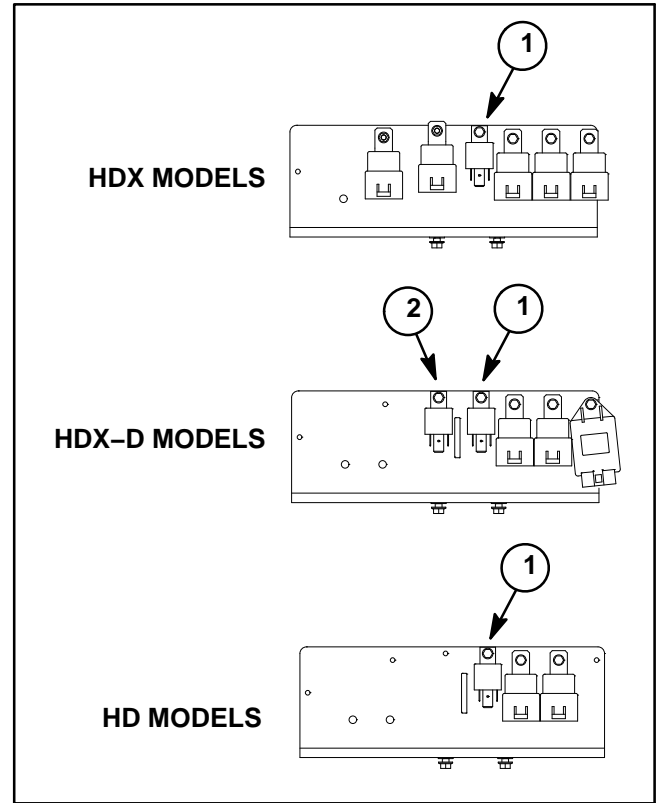

Figure 20

1. Main power relay
2. Glow relay

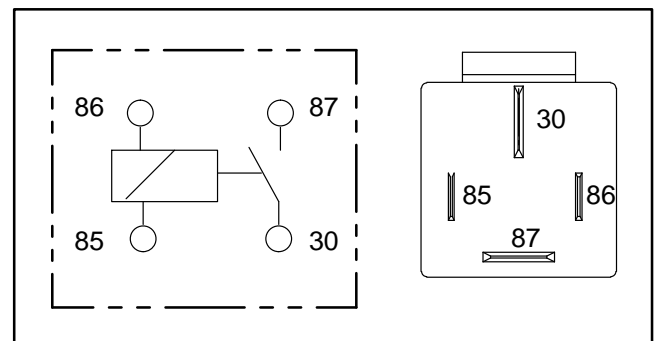

Figure 21

## Relay (Five Terminals)

Workman HD series vehicles use a number of relays that have five (5) terminals:

The start enable relay on Workman HD, HDX and HDX-D vehicles ensures that the clutch pedal is depressed before the engine starter can be engaged.

The start relay on Workman HD, HDX and HDX-D vehicles ensures that the hydraulic lift lever is in neutral before the engine starter solenoid can be energized.

The fan relay on Workman HDX and HDX-D vehicles powers the engine cooling fan the relay is energized.

The ECU power relay on Workman HDX vehicles supplies power to the engine Electronic Control Unit (ECU), the fuel pump relay, the engine Oxygen (O2) sensor, and the Electronic Throttle Valve (ETV) relay.

The ETV relay on Workman HDX vehicles provides power to the engine Electronic Throttle Valve (ETV) through the engine Electronic Control Unit (ECU).

The fuel pump relay on Workman HDX vehicles allows current to the fuel pump when the relay is energized.

The differential relay on Workman HDX 4WD and HDX-D 4WD vehicles are used to make sure that the front wheel drive differential solenoid is not energized when the clutch is disengaged or when the brake is applied.

The kill relay on Workman HD vehicles allows the engine to run as long as the relay is energized. If the ignition switch is in the OFF position or the transmission lockout switches are all open, the relay will not be energized and the engine will stop running.

The start enable relay and the differential relay (4WD vehicles) are located behind the dash panel. The other relays are attached to the relay bracket under the right side of the bed near the rear axle (Fig. 22).

### Testing

1. Park machine on a level surface and apply parking brake. If relay is located on relay bracket, raise bed and install bed support on bed lift cylinder to prevent bed from lowering. Stop engine and remove key from ignition switch. If relay is located behind dash panel, remove hood (see Hood Removal in Chapter 7 – Chassis).

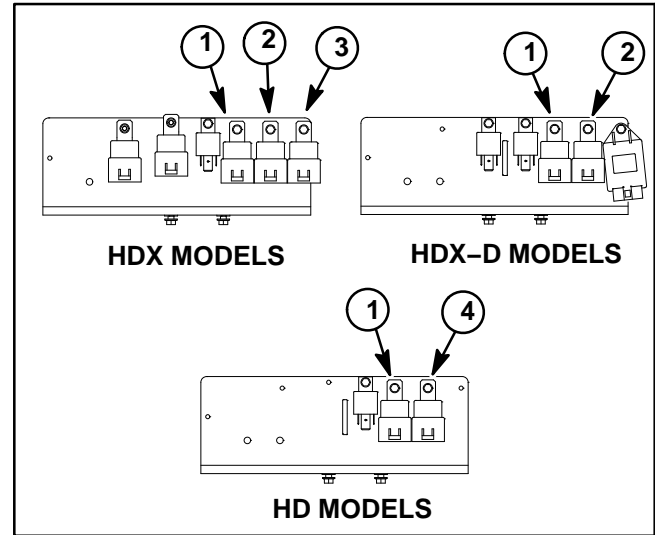

Figure 22

- 1. Start relay
- 2. Fan relay
- 3. Fuel pump relay
- 4. Kill relay

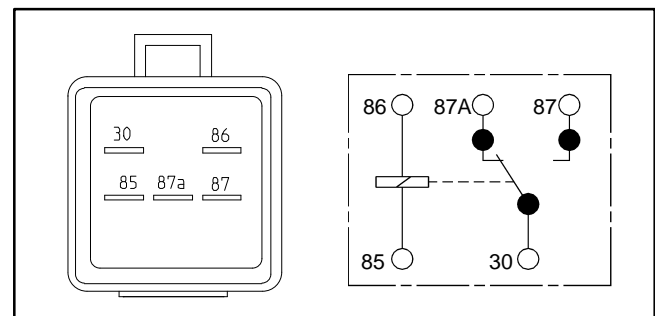

Figure 23

2. Locate relay that is to be tested and disconnect the wire harness connector from the relay. Remove relay from machine for easier testing.

**NOTE:** Prior to taking small resistance readings with a digital multimeter, short the meter test leads together. The meter will display a small resistance value (usually 0.5 ohms or less). This resistance is due to the internal resistance of the meter and test leads. Subtract this value from the measured value of the component you are testing.

3. Using a multimeter (ohms setting), measure coil resistance between terminals 85 and 86 (Fig. 23). Resistance should be between 70 and 90 ohms.



4. Connect multimeter (ohms setting) leads to relay terminals 30 and 87 (Fig. 23). Ground terminal 86 and apply +12 VDC to terminal 85. The relay should make and break continuity between terminals 30 and 87 as +12 VDC is applied and removed from terminal 85.

5. Disconnect voltage from terminal 85 and multimeter lead from terminal 87.

6. Connect multimeter (ohms setting) leads to relay terminals 30 and 87A. Apply +12 VDC to terminal 85. The relay should make and break continuity between terminals 30 and 87A as +12 VDC is applied and removed from terminal 85.

7. Disconnect voltage and multimeter leads from the relay terminals.

8. Replace relay if testing determines that relay is faulty.

9. After testing is complete, secure relay to machine and connect wire harness connector to relay.

## Fusible Link

A Workman HD series vehicle uses three (3) fusible links for circuit protection. These fusible links are located in a harness that connects the starter B+ terminal to the vehicle wire harness (Fig. 24). If any of these links should fail, current to the protected circuit will cease. Refer to electrical schematics and wire harness drawings in Chapter 11 – Electrical Drawings for additional fusible link information.

### Testing

1. Park machine on a level surface, raise bed, stop engine, apply parking brake and remove key from ignition switch.

2. Install bed support on bed lift cylinder to prevent bed from lowering.

3. Disconnect negative battery cable from battery terminal and then disconnect positive cable from battery (see Battery Service in the Service and Repairs section of this chapter).

4. Locate and unplug fusible link connector P1 from vehicle wire harness.

5. Use a multimeter to make sure that continuity (zero ohms) exists between each terminal pin in connector P1 and connector J1 at the starter (Fig. 25). If any of the fusible links are open (infinite ohms), replace the fusible link harness.

6. After testing is complete, make sure that fusible link harness connectors are securely attached to starter and vehicle wire harness.

7. Connect positive battery cable to battery terminal first and then connect negative cable to battery.

8. Remove bed support from lift cylinder and lower bed.

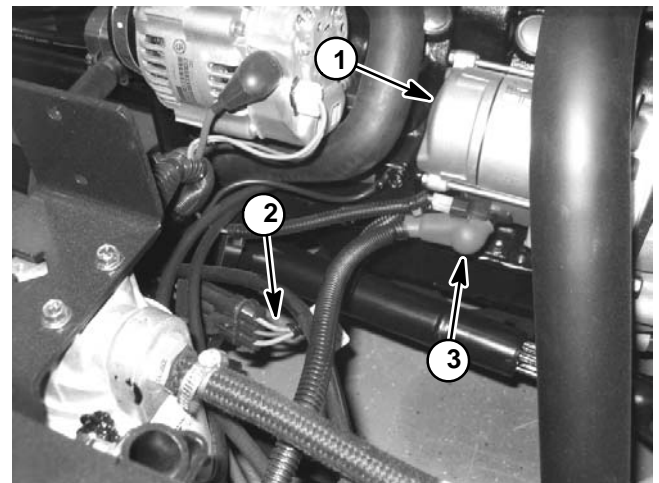

Figure 24

- 1. Starter motor
- 2. Fusible link harness
- 3. Starter B+ terminal

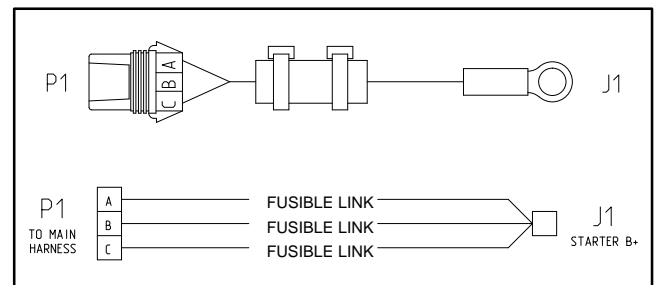

Figure 25

## Diodes

A diode is used for starting circuit protection from voltage spikes that occur when the starter solenoid is de-energized.

If a vehicle is equipped with the optional High Flow Hydraulics Kit, an additional diode is used for circuit protection from voltage spikes that occur when the Kit hydraulic solenoid is de-energized.

If a vehicle is equipped with the optional light kit that includes flashers, two (2) additional diodes are used for flasher circuit logic.

These diodes plug into the vehicle wiring harness at various locations (see appropriate vehicle electrical schematic and wire harness drawings in Chapter 11 – Electrical Drawings).

### Testing

The diodes can be individually tested using a digital multimeter (diode test or ohms setting) and the table to the right.

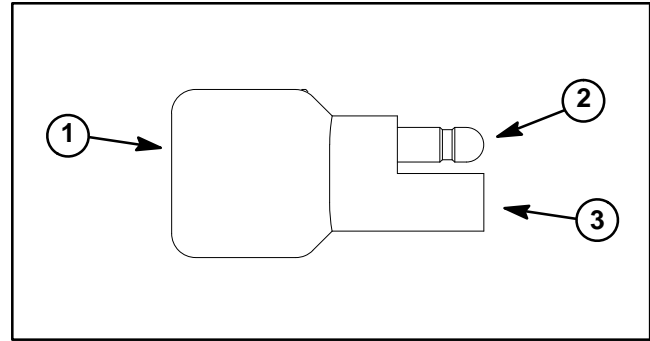

Figure 26

- 1. Diode
- 2. Male terminal
- 3. Female terminal

Multimeter Red Lead (+) on Terminal	Multimeter Black Lead (-) on Terminal	Continuity
Female	Male	YES
Male	Female	NO

## Electronic Throttle Control (Workman HDX)

The engine speed on the Workman HDX (Kubota EFI gasoline engine) is controlled by an electronic throttle system. The system includes an electronic throttle control at the accelerator pedal and a throttle control valve at the Kubota gasoline engine. The engine ECU uses the position of the throttle control at the accelerator pedal as an input to determine the appropriate signal output for the throttle control valve at the engine to set the engine speed.

The electronic throttle control at the accelerator pedal is a non-contact rotary hall effect sensor that varies output voltage based on the sensor position. Use the Kubota Gasoline Service Tool (KGST) and software, and the Kubota Diagnostic Manual for WG972 engines to test the electronic throttle control. Contact your Toro distributor for assistance in Kubota engine troubleshooting.

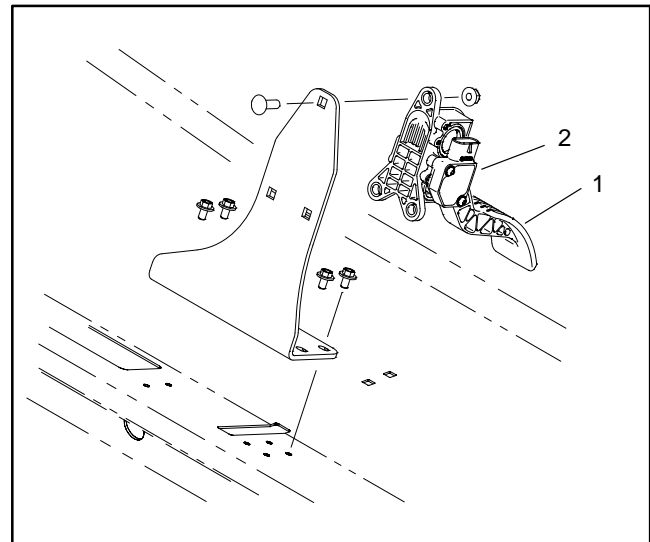

Figure 27

- 1. Accelerator pedal
- 2. Rotary hall effect sensor

## Fuel Run/Stop Solenoid (Workman HDX–D)

The fuel run/stop solenoid used on the Workman HDX–D (Kubota Diesel engine) must be energized for the diesel engine to run. The solenoid is mounted to the injection pump on the engine (Fig. 28).

The fuel run/stop solenoid includes two coils for operation, the pull coil and the hold coil. When the ignition switch is turned to START, the solenoid is initially energized and the pull coil retracts the solenoid plunger. Once the plunger is retracted, the hold coil will keep it retracted for continued engine operation. When the solenoid is de-energized, the plunger extends to shut off fuel supply to the engine causing the engine to stop running. The fuel run/stop solenoid is grounded through the solenoid housing.

**NOTE:** Refer to Chapter 11 – Electrical Diagrams in this manual when troubleshooting the fuel run/stop solenoid.

### In Place Testing

**NOTE:** Prior to taking small resistance readings with a digital multimeter, short the test leads together. The meter will display a small resistance value (usually 0.5 ohms or less). This resistance is due to the internal resistance of the meter and test leads. For accurate test results, subtract this value from the measured value of the component you are testing.

1. Make sure ignition switch is in the OFF position. Disconnect wire harness connector from run/stop solenoid.
2. Using a digital multimeter, touch one test lead to the pull coil terminal and the other test lead to the run/stop solenoid frame (ground) (Fig. 29). The resistance of the pull coil should be less than 1 ohm (but not zero).
3. Using a digital multimeter, touch one test lead to the hold coil terminal and the other test lead to the fuel stop solenoid frame (ground) (Fig. 29). The resistance of the hold coil should be approximately 15.5 ohms.
4. Reconnect solenoid to the wiring harness.

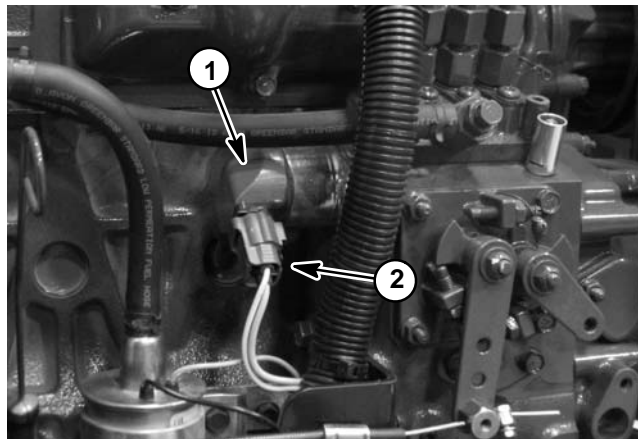

Figure 28

1. Fuel stop solenoid
2. Harness connector

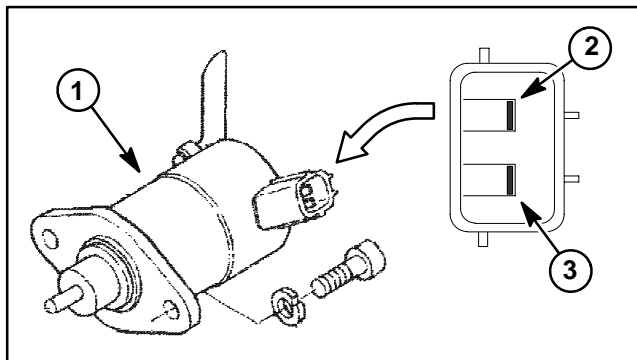

Figure 29

1. Fuel stop solenoid
2. Pull coil terminal
3. Hold coil terminal

## Fuel Gauge Sender (Workman HD & HDX-D)

The fuel gauge sender is located in the fuel tank (Fig. 30). The fuel gauge sender on Workman HDX vehicles (Kubota EFI gasoline engine) is included with the fuel pump and fuel filter assembly that fits into the fuel tank. Use the following procedure to test either style sender.

### Testing

1. Park machine on a level surface, raise bed, stop engine, apply parking brake and remove key from ignition switch. Install bed support on bed lift cylinder to prevent bed from lowering.
2. Disconnect the wire harness connector (white and black wires) from the fuel sender.



## CAUTION

**When testing circuit wiring and fuel gauge, make sure wire connections are secure before turning ignition switch to ON to prevent an explosion or fire from sparks.**

3. To test the circuit wiring and fuel gauge, use a jumper wire to connect the two (2) terminals in the wire harness connector. Make sure that jumper wire connections are secure. Turn ignition switch to ON. Fuel gauge should indicate a full fuel tank. Turn ignition switch OFF and continue testing fuel sender if circuit wiring and gauge are acceptable.

4. Remove fuel hoses from fuel sender fittings. Remove fuel sender cap that secures the sender in the fuel tank.

**NOTE:** Do not allow fuel sender assembly to rotate during removal or damage to the sender float arm may result.

5. Remove sender and gasket from the fuel tank. Clean all fuel from the sender.



## CAUTION

**Make sure sending unit is completely dry (no fuel on it) before testing. Perform test away from the tank to prevent an explosion or fire from sparks.**

6. Check resistance of the sender with a multimeter.
  - A. Resistance with the float in the full position (completely up) should be from 5 to 8 ohms.
  - B. Resistance with the float in the empty position (completely down) should be from 89 to 95 ohms.

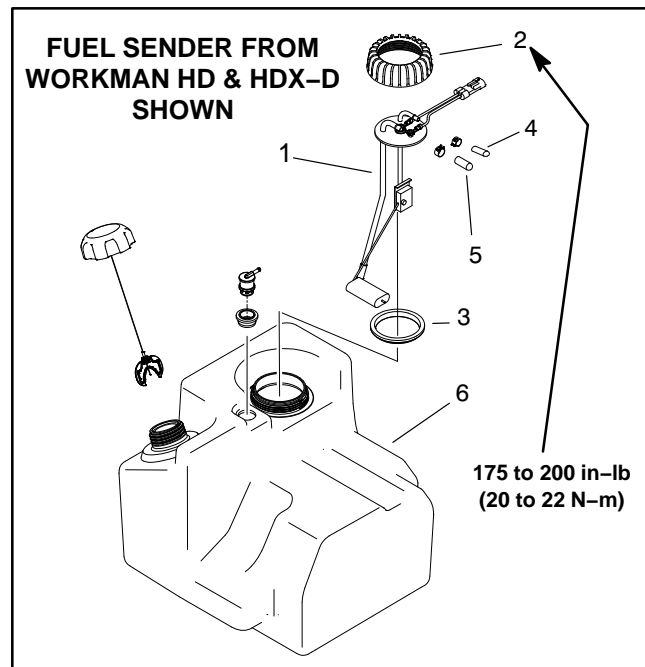

Figure 30

- |                      |                            |
|----------------------|----------------------------|
| 1. Fuel gauge sender | 4. Fuel hose (from engine) |
| 2. Fuel sender cap   | 5. Fuel hose (to pump)     |
| 3. Gasket            | 6. Fuel tank               |

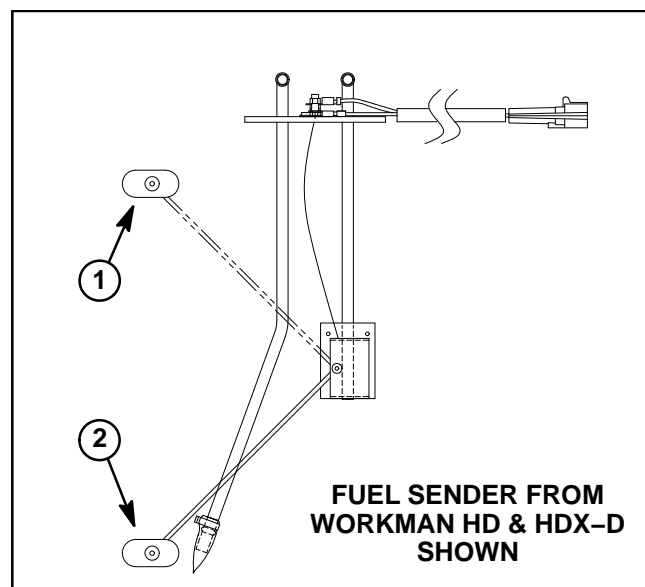

Figure 31

- |                         |                          |
|-------------------------|--------------------------|
| 1. Sender full position | 2. Sender empty position |
|-------------------------|--------------------------|

7. Replace fuel gauge sender if necessary.

8. After testing, install sender into fuel tank and secure with gasket and fuel sender cap. Secure fuel hoses to fittings on sender and connect fuel sender connector to wire harness.

9. Remove bed support from bed lift cylinder and lower bed.

## Fuel Pump/Sender (Workman HDX)

The electric fuel pump/sender used on Workman HDX vehicles (Kubota EFI gasoline engine) is a combination positive displacement pump that provides pressurized fuel to the engine fuel rail in a return-less system, and a fuel level sending unit. The fuel pump assembly includes a regulator to maintain fuel pressure of approximately 40 PSI (276 kPa).

Electrical power for the fuel pump is available when the fuel pump relay is energized by the engine ECU and when one or more of the transaxle switches are closed (e.g. transaxle is in 2nd gear, transaxle is in low range, or 3<sup>rd</sup>-high lockout switch is in fast position).

**NOTE:** When the ignition switch is turned to RUN, the engine ECU energizes the fuel pump relay for approximately three (3) seconds which allows the fuel system to be pressurized.

### Fuel Pump Testing

1. Park vehicle on a level surface, raise bed and engage parking brake. Stop the engine and remove key from ignition switch. Allow engine to cool.
2. Install bed support on bed lift cylinder to prevent bed from lowering.

**CAUTION**

**The fuel supply hose will contain pressurized fuel. Be careful when disconnecting fuel supply hose. Wipe up any spilled fuel before starting the engine.**

3. Disconnect fuel supply hose from engine fuel rail (Fig. 33).
4. Install a fuel pressure gauge capable of measuring 50 PSI (350 kPa) to the disconnected hose.

**NOTE:** If pressure gauge is connected to a tee fitting, fuel rail and injectors can be checked for potential leakage while measuring fuel pump pressure.

5. While monitoring pressure gauge, turn ignition switch to ON so that fuel pump relay and pump are energized. Fuel pressure displayed on the gauge should rise. After pump relay is de-energized (approximately 3 seconds), turn ignition switch to OFF and then back to ON to re-energize the fuel pump relay and fuel pump. Fuel pump pressure should be approximately 40 PSI (276 kPa).

6. If fuel pump pressure is low, make sure that electrical power is available to pump and then consider a clogged fuel filter or faulty fuel pump (see Fuel Pump in the Service and Repairs section of Chapter 3 – Kubota EFI Gasoline Engine Gasoline Engine).

7. After testing is completed, remove pressure gauge from fuel supply hose. Connect fuel supply hose to engine fuel rail and secure with hose clamp.

8. Remove bed support from bed lift cylinder and lower bed.

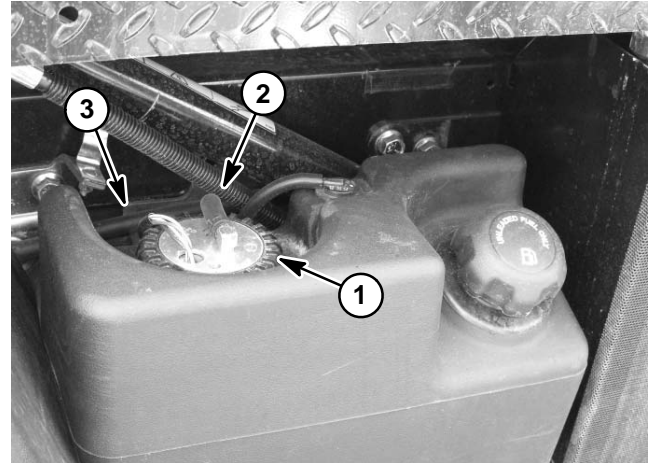

Figure 32

- |                          |                        |
|--------------------------|------------------------|
| 1. Fuel pump/sender      | 3. Pump/sender harness |
| 2. Fuel hose (to engine) |                        |

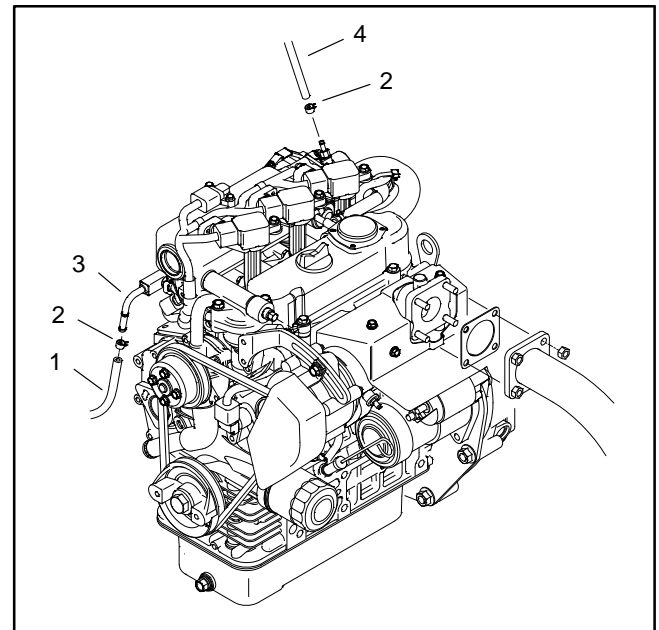

Figure 33

- |                     |                       |
|---------------------|-----------------------|
| 1. Fuel supply hose | 3. Fuel inlet fitting |
| 2. Hose clamp       | 4. Fuel return hose   |

## Fuel Pump (Workman HDX-D)

The fuel pump is attached to the left frame rail near the engine.

### Operational Test

1. Park machine on a level surface, lower cutting decks, stop engine, and engage parking brake. Unlatch and raise hood.
2. Disconnect electrical connector from the fuel stop/run solenoid to prevent the engine from starting.
3. Disconnect the fuel hose between the pump and the filter/separator (pump discharge) at the filter separator.
4. Make sure fuel hoses to and from the fuel pump are not kinked, damaged, and free of obstructions.
5. Place disconnected fuel hose into a graduated cylinder with at least a 1 quart (0.95 liter) capacity.

**IMPORTANT: When testing the fuel pump, DO NOT turn ignition switch to START.**

6. Collect fuel in the graduated cylinder by turning ignition switch to the RUN position. Allow pump to run for time listed below, then return switch to OFF. The amount of fuel collected in the graduated cylinder should be approximately **21 to 37 fl oz (0.62 to 1.1 Ltr) after thirty (30) seconds.**
7. Replace fuel pump as necessary. Reconnect fuel hose to the fuel filter/separator.
8. Reconnect electrical connector to the fuel run/stop solenoid.
9. Bleed fuel system.

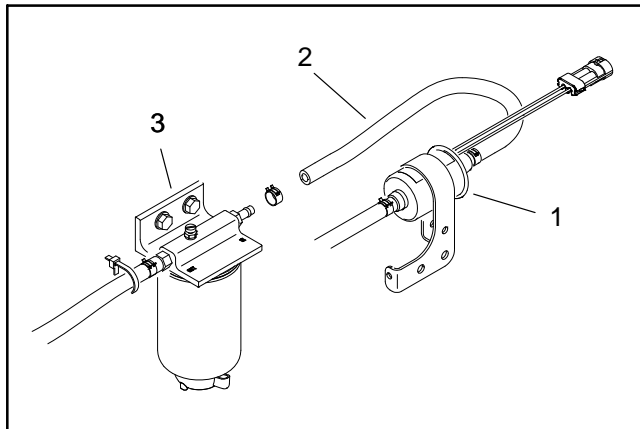

Figure 34

1. Fuel pump
2. Fuel hose (discharge)
3. Fuel filter/separator

### Fuel Pump Specifications

Pump Capacity	42 to 74 fl oz/min (1.2 to 2.2 Ltr/min)
Pressure	2.3 psi (15.8 kPa)
Max. Current Draw	1.8 amp

## Temperature Sender (Workman HDX and HDX-D)

Liquid cooled vehicles have a temperature sender threaded into the water pump housing on the engine (Fig. 35). The resistance of the temperature sender reduces as the engine coolant temperature increases. This resistance change is used by the instrument cluster to display engine operating temperature. There is a yellow wire attached to the sender.

### Testing

1. Park machine on a level surface, raise bed, stop engine, apply parking brake and remove key from ignition switch.
2. Install bed support on bed lift cylinder to prevent bed from lowering.



## CAUTION

**Make sure engine is cool before removing the temperature switch.**

3. Lower the coolant level in the engine, remove wire harness connector from temperature sender and remove the sender from the engine.
4. Put switch in a container of oil with a thermometer and slowly heat the oil (Fig. 36).



## CAUTION

**Handle the hot oil with extreme care to prevent personal injury or fire.**

**NOTE:** Prior to taking resistance readings with a digital multimeter, short the meter test leads together. The meter will display a small resistance value (usually 0.5 ohms or less). This resistance is due to the internal resistance of the meter and test leads. Subtract this value from the measured value of the component you are testing.

5. Check resistance of the sender with a multimeter (ohms setting) as the temperature increases. Replace sender if specifications are not met.

COOLANT TEMP	TEMP SENDER RESISTANCE
100F (38C)	405 to 495 ohms
160F (71C)	120 to 140 ohms
220F (105C)	44 to 48 ohms

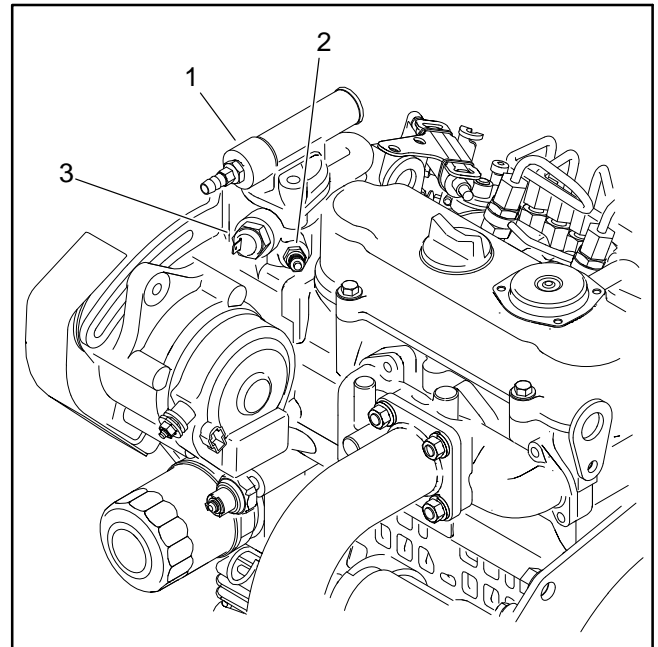

Figure 35

1. Water pump housing
2. Temp sender
3. Thermal fan switch (HDX-D only)

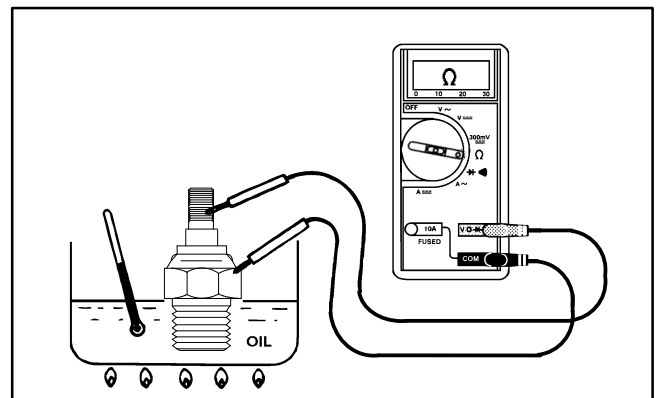

Figure 36

6. Replace temperature sender if necessary.
7. Install switch to the water pump.
  - A. Clean threads of water pump housing and switch thoroughly. Apply thread sealant to the threads of the switch.
  - B. Install switch into the water pump housing and tighten.
  - C. Connect yellow wire harness wire to switch.
8. Fill engine cooling system.
9. Remove bed support from lift cylinder and lower bed.

## Electric Fan Thermal Switch (Workman HDX-D)

The thermal fan switch is threaded into the thermostat housing on the engine (Fig. 37). The fan switch is a normally open switch that closes when the engine coolant temperature reaches 190F to 210F (88C to 99C). There is a green wire attached to the switch. When the thermal fan switch closes, the radiator fan is energized.

### Testing

1. Park machine on a level surface, raise bed, stop engine, apply parking brake and remove key from ignition switch.
2. Install bed support on bed lift cylinder to prevent bed from lowering.



3. Lower the coolant level in the engine, remove wire harness connector from thermal fan switch and remove the switch from the engine.
4. Put fan switch in a container of oil with a thermometer and slowly heat the oil (Fig. 38).



**NOTE:** Prior to taking resistance readings with a digital multimeter, short the meter test leads together. The meter will display a small resistance value (usually 0.5 ohms or less). This resistance is due to the internal resistance of the meter and test leads. Subtract this value from the measured value of the component you are testing.

5. Check continuity of the switch with a multimeter (ohms setting). The thermal fan switch is normally open and should close at approximately 190F to 210F (88C to 99C). As the switch cools, it should open at approximately the same temperature.
6. Replace thermal fan switch if necessary.

7. Install fan switch to the water pump.
  - A. Clean threads of water pump housing and switch thoroughly. Apply thread sealant to the threads of the switch.
  - B. Install switch into the water pump housing and tighten.
  - C. Connect green wire harness wire to switch.
8. Fill engine cooling system.
9. Remove bed support from lift cylinder and lower bed.

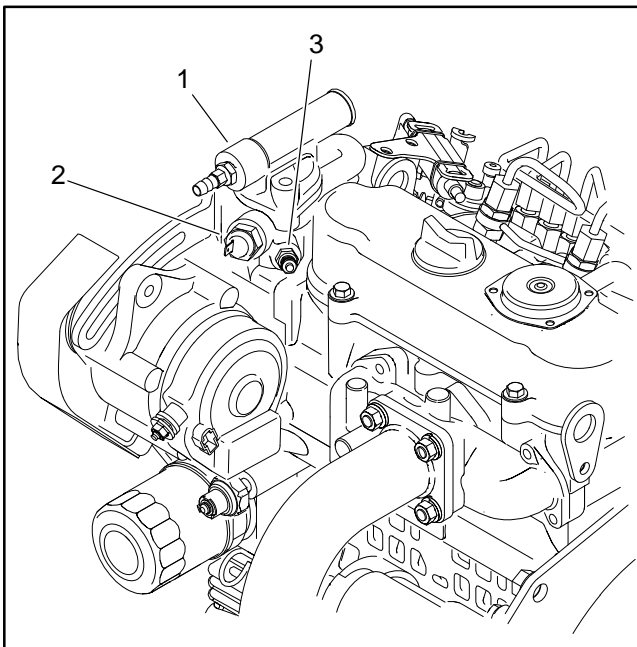

Figure 37

1. Thermostat housing
2. Thermal fan switch
3. Temp sender

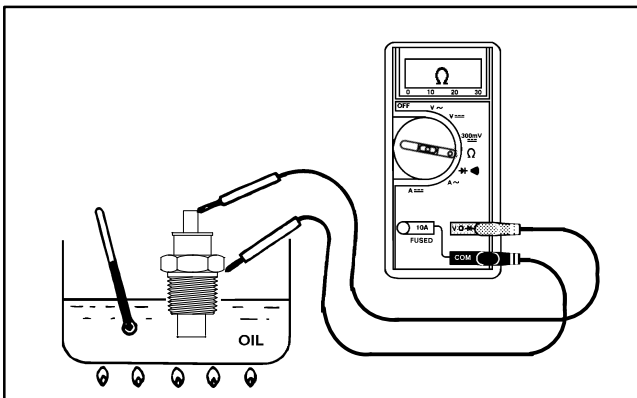

Figure 38



## Speed Sensor

**NOTE:** The speed sensor and speedometer are standard equipment on the Workman HDX and HDX-D, and optional equipment on the Workman HD.

The speed sensor is attached to the upper transaxle cover (Fig. 39). It uses a magnetically based, Hall Effect integrated circuit to provide a signal to the speedometer. As the differential in the transaxle turns, the sensor accurately senses the movement of the differential ring gear teeth passing by the sensor. The red striped connector wire is the sensor positive lead, the black wire is the ground lead and the green wire is the signal output.

### Testing

1. Park machine on a level surface, raise bed, stop engine, apply parking brake and remove key from ignition switch.
2. Install bed support on bed lift cylinder to prevent bed from lowering.
3. Locate traction speed sensor on the transaxle assembly. Disconnect the wire harness connector from the traction speed sensor.
4. Remove flange head screw that secures speed sensor to transaxle. Remove speed sensor from transaxle.

**IMPORTANT: Incorrect jumper wire connections during testing can damage the sensor.**

5. Using a +12 VDC battery, a multimeter, a 1K ohm resistor and appropriate jumper wires, connect the battery and multimeter to the speed sensor using Figure 40 as a guide.
6. Set multimeter to DC volts setting.
7. The multimeter should display very low voltage when a metal object is held near the sensor tip. The multimeter should display battery voltage when the metal object is moved away from the sensor tip.
8. After testing is complete, remove jumper wires, resistor and multimeter leads from sensor connector.
9. Replace speed sensor if necessary.
10. Inspect sensor seal condition and replace if necessary.
11. Install speed sensor into transaxle and secure with flange head screw. Reconnect speed sensor to wire harness.
12. Remove bed support from lift cylinder and lower bed.

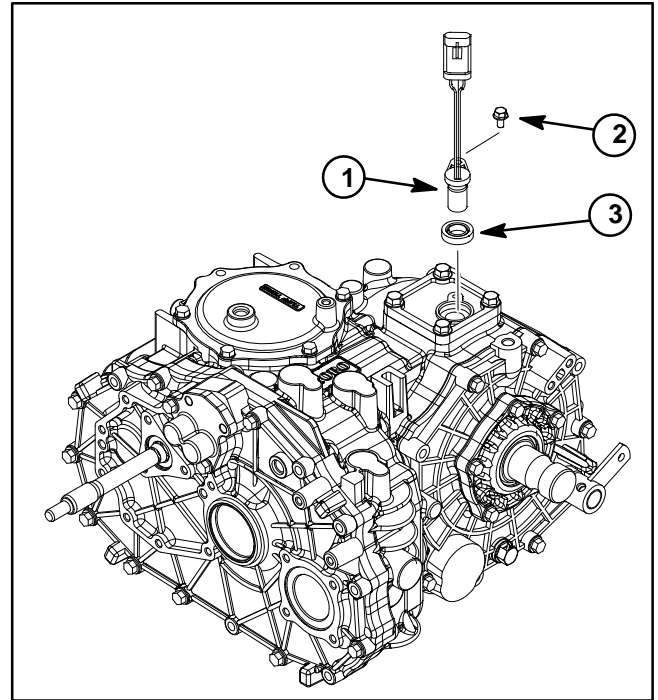

Figure 39

- |                      |         |
|----------------------|---------|
| 1. Speed sensor      | 3. Seal |
| 2. Flange head screw |         |

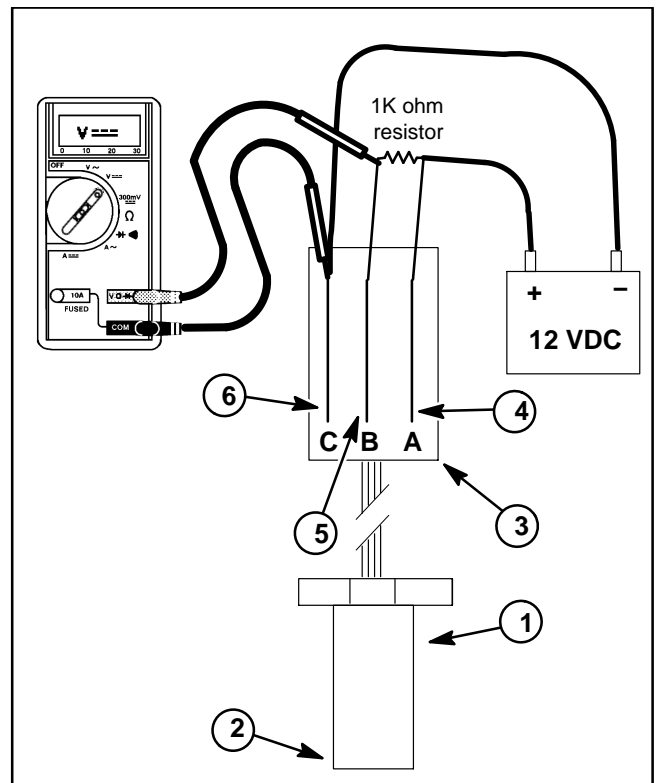

Figure 40

- |                     |                     |
|---------------------|---------------------|
| 1. Speed sensor     | 4. Red striped wire |
| 2. Sensor tip       | 5. Green wire       |
| 3. Sensor connector | 6. Black wire       |

## Glow Controller (Workman HDX-D)

The controller is located under the instrument panel.

**NOTE:** Refer to Electrical Diagrams – Chapter 11 in this manual when troubleshooting the glow controller.

### Controller Operation

1. When the ignition switch is placed in the RUN position, the controller energizes the glow plug relay and illuminates the glow lamp for 10 seconds.
2. When the ignition switch is held in the START position, the glow plug relay will energize while the switch is held in START and the glow lamp will not illuminate.
3. When the ignition switch is released from START to RUN, the glow plug relay will de-energize and the glow lamp will remain off.

### Controller Checks

1. Make sure there is power from the battery.
2. Disconnect electrical connector to the fuel stop solenoid to prevent the engine from starting.
3. Place ignition switch in the RUN position. Verify the following while in the RUN position:
  - A. Glow indicator lamp is on.
  - B. Glow relay is energized.
  - C. Glow plugs are energized.
  - D. Glow indicator lamp goes out and glow plugs de-energize after 10 seconds.
4. Place ignition switch in the START position. Verify the following while in the START position:
  - A. Glow indicator lamp is out.
  - B. Glow relay is energized.
  - C. Glow plugs are energized.
  - D. Power exists at terminal 1 of the glow controller.

**NOTE:** If there is no power to terminal 1 of the glow controller, verify continuity of the circuitry from the ignition switch to the controller and perform Step 4 again (see Electrical Diagrams – Chapter 11 in this manual).

5. If any of the conditions in Step 3 are not met or power to terminal 1 exists and any of the other conditions in Step 4 are not met:

- A. Verify continuity of the circuitry from the battery to the glow relay and glow plugs (see Electrical Diagrams – Chapter 11 of this manual).
- B. Verify continuity of the circuitry from the battery to ignition switch, glow controller, glow lamp, glow relay, and ground (see Electrical Diagrams – Chapter 11 in this manual).
- C. Replace parts as necessary.

6. Connect electrical connector to the fuel stop solenoid when finished.

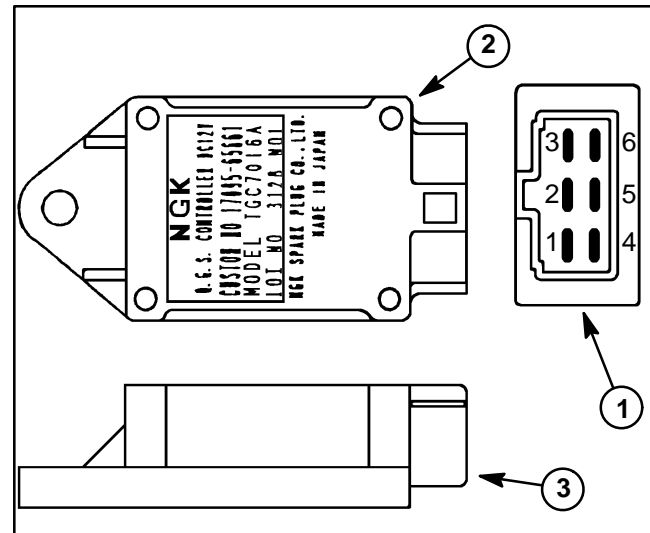

Figure 41

1. Glow controller end view
2. Top view
3. Side view

## High Flow Hydraulics Kit Switch (High Flow Hydraulics Kit)

On vehicles equipped with the high flow hydraulics kit, the switch to engage the high flow hydraulic circuit is mounted on the dash (Fig. 42). When the high flow hydraulics kit switch is ON, the solenoid coil on the control manifold is energized to allow hydraulic flow to the attachment. An indicator light on the switch identifies when the switch is ON.

### Testing

1. Park machine on a level surface, stop engine, apply parking brake and remove key from ignition switch.
2. Locate switch on dash and disconnect wire harness electrical connector from the switch.
3. With the use of a multimeter (ohms setting), the switch functions may be tested to determine whether continuity exists between the various terminals for each switch position. The switch terminals are marked as shown (Fig. 43). The circuitry of this switch is shown in the chart below. Verify continuity between switch terminals for each switch position.

SWITCH POSITION	NORMAL CIRCUITS	OTHER CIRCUITS
ON	2 + 3	5 + 6
OFF	2 + 1	5 + 4

4. After testing, connect wire harness electrical connector to the switch.

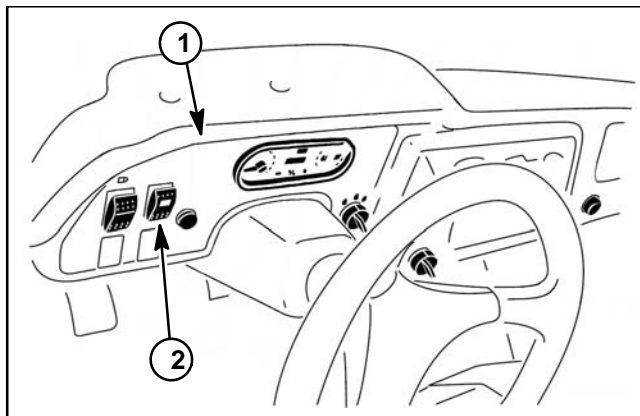

Figure 42

1. Dash
2. High flow switch

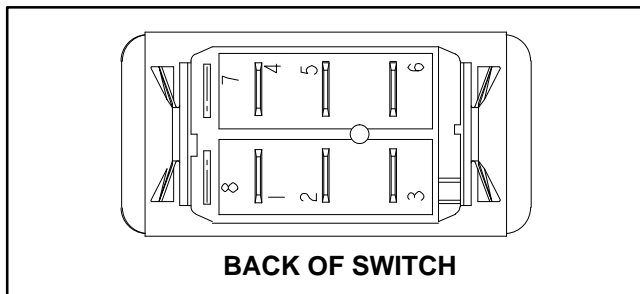

Figure 43

## Hydraulic Solenoid Valve Coil (High Flow Hydraulics Kit)

Vehicles equipped with the High Flow Hydraulics Kit use a hydraulic solenoid valve coil for system control (Fig. 44). When the solenoid coil is energized, hydraulic valve shift occurs to provide hydraulic flow for the attachment. Testing of the coil can be done with the coil installed on the hydraulic manifold.

### Testing

1. Park machine on a level surface, raise bed, stop engine, apply parking brake and remove key from ignition switch.
2. Install bed support on bed lift cylinder to prevent bed from lowering.
3. Disconnect wire harness connector from hydraulic solenoid valve coil.

**NOTE:** Prior to taking small resistance readings with a digital multimeter, short the meter test leads together. The meter may display a small resistance value (usually 0.5 ohms or less). This resistance is due to the internal resistance of the meter and test leads. Subtract this value from the measured value of the component you are testing.

4. Using a multimeter (ohms setting), measure resistance between the two connector terminals on the solenoid coil. The resistance for the coil should be approximately 7.1 ohms at 68F (20C).

5. After testing is complete, connect wire harness connector to the solenoid coil.

6. Remove bed support from lift cylinder and lower bed.

### Solenoid Coil Replacement

1. Remove nut that secures solenoid coil to cartridge valve.
2. Carefully slide coil from valve.
3. When installing coil on cartridge valve, torque nut to **5 ft-lb (6.8 N-m)**.

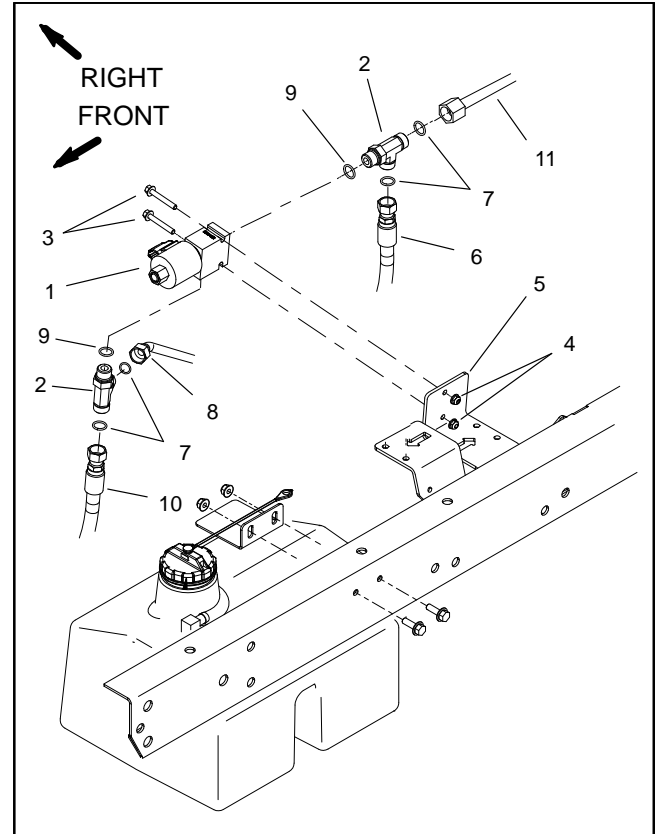

Figure 44

- |                          |                    |
|--------------------------|--------------------|
| 1. Hydraulic manifold    | 7. O-ring          |
| 2. Hydraulic tee fitting | 8. Hydraulic tube  |
| 3. Flange head screw     | 9. O-ring          |
| 4. Flange nut            | 10. Hydraulic hose |
| 5. Frame bracket         | 11. Hydraulic tube |
| 6. Hydraulic hose        |                    |

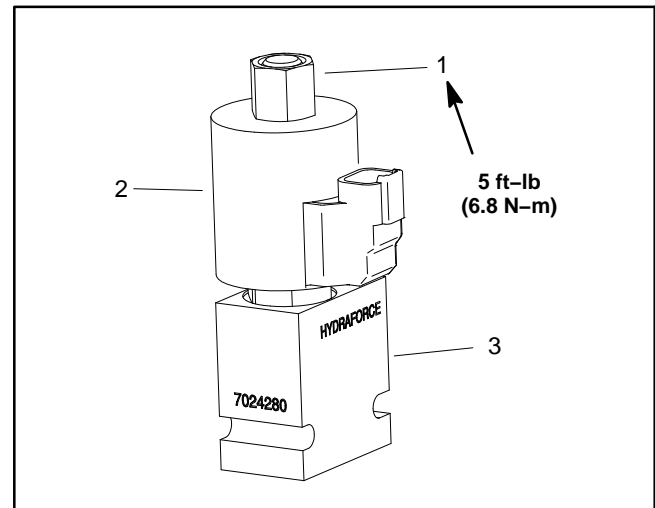

Figure 45

- |                  |                  |
|------------------|------------------|
| 1. Nut           | 3. Manifold body |
| 2. Solenoid coil |                  |

## Rear PTO Switch (Optional Kit)

On vehicles equipped with the optional rear PTO kit, the rear PTO switch is located in the rear PTO housing mounted on the top of the transaxle. The Rear PTO switch is normally closed and opens when the PTO is engaged.

### Testing

1. Park machine on a level surface, raise bed, stop engine, apply parking brake and remove key from ignition switch.
2. Install bed support on bed lift cylinder to prevent bed from lowering.
3. Locate rear PTO switch and disconnect the wire harness connector from the switch.
4. Use a multimeter (ohms setting) to test for continuity across the two (2) switch terminals. With the engine off and the PTO lever in the OFF position, there **should be** continuity (zero ohms). Move PTO lever to ON and there **should not be** continuity (infinite ohms).
5. If necessary, replace switch.
6. When switch testing is complete, connect wire harness connector to switch.
7. Remove bed support from lift cylinder and lower bed.

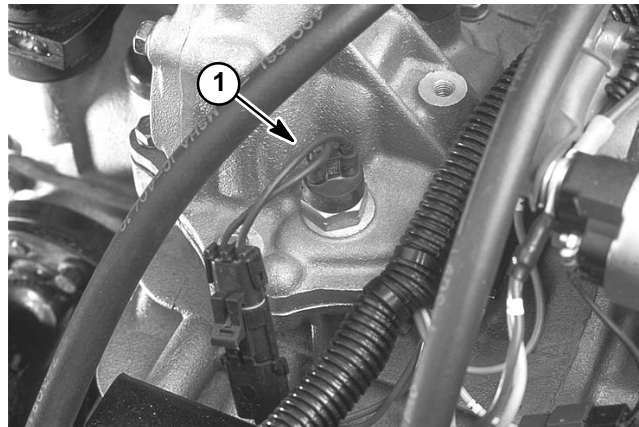

Figure 46  
1. Rear PTO switch

## Interlock Switch (1/3 Area Lift Platform Kit)

A proximity switch is attached to the frame under the dash of units with a 1/3 area lift platform installed. The switch is in its closed position as long as the parking brake is released. When the parking brake is engaged, the brake lever moves away from the switch causing the contacts to open. The switch is used in the starting interlock system to make sure that the lift platform is not in use during engine startup.

### Testing

1. Park vehicle on a level surface, shut engine off, remove key from ignition switch and chock wheels. Locate the interlock switch (Fig. 47).
2. Remove knob from gear shift lever, then remove boot plate and shifter boot from seat base (Fig. 48). Additional access may be necessary and can be obtained by removing the control plate.
3. Use a multimeter (ohms setting) to test continuity across the switch terminals. Disconnect the wire harness connector from switch. Check continuity across the two (2) switch terminals. There **should be** continuity (zero ohms) when the parking brake is released and there **should not be** continuity (infinite ohms) when the parking brake is engaged.
4. After switch testing is completed, connect the wire harness connector(s) to the switch.
5. Secure shifter boot and boot retainer to seat base with removed screws. Install knob on gear shift lever.

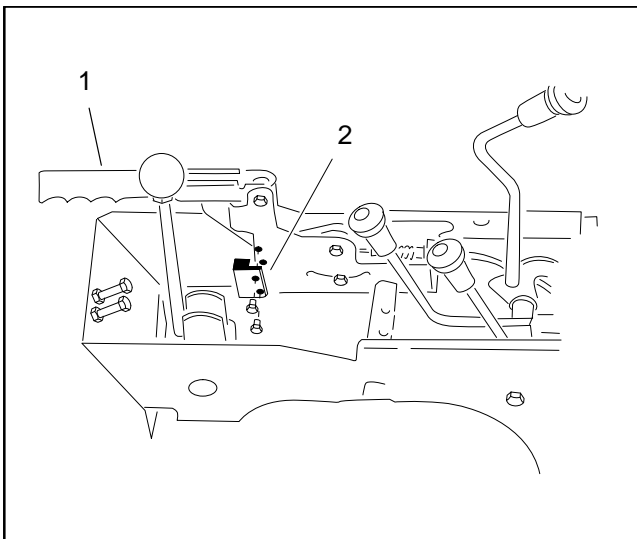

Figure 47

1. Parking brake                      2. Interlock switch

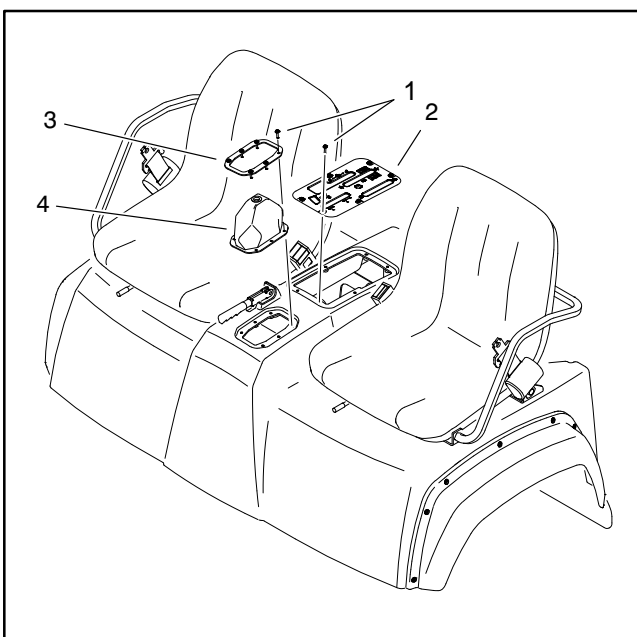

Figure 48

1. Screw                                      3. Boot plate  
2. Control plate                            4. Shifter boot

# Service and Repairs

**NOTE:** Refer to the appropriate engine Service Manual for engine electrical component repair information.

---

## Battery Storage

If the machine will be stored for more than 30 days:

1. Remove the battery from the machine and charge it fully (see Battery Service).
2. Either store battery on a shelf or on the machine.
3. Leave battery cables disconnected if the battery is stored on the machine.

4. Store battery in a cool atmosphere to avoid quick deterioration of the battery charge.

5. To help prevent the battery from freezing, make sure it is fully charged (see Battery Service).

---

## Battery Care

1. Battery electrolyte level must be properly maintained. The top of the battery must be kept clean. If the machine is stored in a location where temperatures are extremely high, the battery will discharge more rapidly than if the machine is stored in a location where temperatures are cool.

3. Battery cables must be tight on terminals to provide good electrical contact.

**CAUTION**

**Wear safety goggles and rubber gloves when working with electrolyte. Charge battery in a well ventilated place so gasses produced while charging can dissipate. Since the gases are explosive, keep open flames and electrical sparks away from the battery; do not smoke. Nausea may result if the gases are inhaled. Unplug battery charger from electrical outlet before connecting or disconnecting charger leads to or from battery posts.**

**CAUTION**

**Connecting battery cables to the wrong battery post could result in personal injury and/or damage to the electrical system.**

4. If corrosion occurs at battery terminals, disconnect cables. Always disconnect negative (–) cable first. Clean clamps and terminals separately. Connect cables to battery with positive (+) cable first. Coat battery posts and cable connectors with Battery Terminal Protector (Toro Part No. 107–0392) or petroleum jelly to prevent corrosion.

5. Periodically (at least every 50 operating hours) check battery electrolyte level. Check electrolyte level every 30 days if machine is in storage.

6. Maintain battery cell level with distilled water. Do not fill battery cells above the fill line.

**IMPORTANT:** Do not remove battery fill caps while cleaning battery.

2. Check battery condition weekly or after every fifty (50) hours of operation. Keep terminals and entire battery case clean because a dirty battery will discharge slowly.

A. Clean battery by washing entire case with a solution of baking soda and water. Rinse with clear water.

B. Coat battery posts and cable connectors with Battery Terminal Protector (Toro Part No. 107–0392) or petroleum jelly to prevent corrosion.

## Battery Service

The battery is the heart of the electrical system. With regular and proper service, battery life can be extended. Additionally, battery and electrical component failure can be prevented.



### CAUTION

When working with batteries, use extreme caution to avoid splashing or spilling electrolyte. Electrolyte can destroy clothing and burn skin and eyes. Always wear safety goggles and a face shield when working with batteries.

### Battery Specifications

BCI Group 26 Battery  
540 Amp Cranking Performance at 0F (-18C)  
80 minute Reserve Capacity at 80F (27C)  
Electrolyte Specific Gravity (fully charged): from 1.250 to 1.280  
Electrolyte Specific Gravity (discharged): 1.240

### Battery Removal and Installation (Fig. 49)

1. Make sure that ignition switch is in the OFF position.
2. Squeeze the battery cover to release cover tabs from battery tray. Remove battery cover from the frame. Loosen battery retainer that secures battery to battery tray.
3. Loosen and remove negative (-) cable from battery. After negative cable has been removed, loosen and remove positive (+) cable.
4. Carefully remove battery from machine.
5. Install battery in reverse order making sure to connect and tighten positive (+) cable to battery before connecting negative (-) cable.

**NOTE:** Before connecting the negative (-) cable to the battery, connect a digital multimeter (set to DC Amps) between the negative battery post and the negative (-) cable connector. The reading should be less than 0.1 amp. If the reading is 0.1 amp or more, the machine's electrical system should be tested for short circuits or faulty components and repaired.

6. Coat battery posts and cable connectors with Battery Terminal Protector (Toro Part No. 107-0392) or petroleum jelly to prevent corrosion.

7. Make sure that battery retainer secures battery in place. Install battery cover to battery tray.

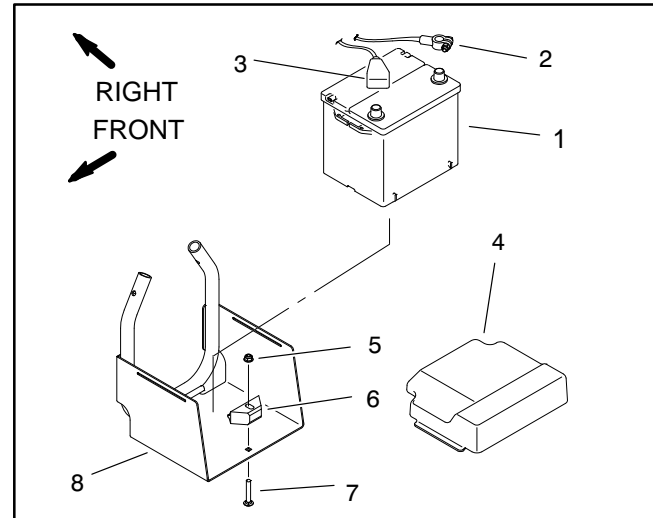

Figure 49

- |                   |                     |
|-------------------|---------------------|
| 1. Battery        | 5. Flange nut       |
| 2. Negative cable | 6. Battery retainer |
| 3. Positive cable | 7. Carriage screw   |
| 4. Cover          | 8. Battery tray     |

### Battery Inspection and Maintenance

1. Check battery case for cracks. Replace battery if cracked or leaking.
2. Check battery terminal posts for corrosion. Use wire brush to clean corrosion from posts.

**IMPORTANT:** Before cleaning the battery, tape or block vent holes to the filler caps and make sure the caps are on tightly.

3. Check for signs of wetness or leakage on the top of the battery which might indicate a loose filler cap, overcharging, a loose terminal post or overfilling. Also, check battery case for dirt and oil. Clean the battery with a solution of baking soda and water, then rinse it with clean water.

4. Check that the cover seal is not broken. Replace the battery if the seal is broken or leaking.



## Battery Testing

1. If battery filler caps are removable, conduct a hydrometer test of the battery electrolyte.

**IMPORTANT: Make sure the area around the cells is clean before opening the battery caps.**

A. Measure the specific gravity of each cell with a hydrometer. Draw electrolyte in and out of the hydrometer barrel prior to taking a reading to warm-up the hydrometer. At the same time take the temperature of the cell.

B. Temperature correct each cell reading. For each 10F (5.5C) above 80F (26.7C) add 0.004 to the specific gravity reading. For each 10F (5.5C) below 80F (26.7C) subtract 0.004 from the specific gravity reading.

**Example:** Cell Temperature                      100F  
 Cell Specific Gravity                              1.245  
 100F minus 80F equals 20F  
 (37.7C minus 26.7C equals 11.0C)  
 20F multiply by 0.004/10F equals 0.008  
 (11C multiply by 0.004/5.5C equals 0.008)  
 ADD (conversion above)                      0.008  
 Correction to 80F (26.7C)                      1.253

C. If the difference between the highest and lowest cell specific gravity is 0.050 or greater or the lowest cell specific gravity is less than 1.225, charge the battery. Charge at the recommended rate and time given in **Charging** or until all cells specific gravity is 1.225 or greater with the difference in specific gravity between the highest and lowest cell less than 0.050. If these charging conditions can not be met, replace the battery.

2. Perform a high-discharge test with an adjustable load tester.

This is one of the most reliable means of testing a battery as it simulates the cold-cranking test. A commercial battery load tester is **required** to perform this test.

	CAUTION
<b>Follow the manufacturer's instructions when using a battery load tester.</b>	

A. Check the voltage across the battery terminals prior to testing the battery. If the voltage is less than 12.4 VDC, charge the battery.

B. If the battery has been charged, apply a 150 amp load for 15 seconds to remove the surface charge. Use a battery load tester **following the manufacturer's instructions.**

C. Make sure battery terminals are free of corrosion.

D. If battery filler caps are removable, measure the temperature of the center cell.

E. Connect a battery load tester to the battery terminals **following the manufacturer's instructions.** Connect a digital multimeter to the battery terminals.

F. Apply a test load of 270 amps (one half the Cranking Performance rating of the battery) for 15 seconds.

G. Take a battery voltage reading at 15 seconds, then remove the load.

H. Using the table below, determine the minimum voltage for the cell temperature reading.

Minimum Voltage	Battery Electrolyte Temperature	
	9.6	70F (and up)
9.5	60F	15.6C
9.4	50F	10.0C
9.3	40F	4.4C
9.1	30F	-1.1C
8.9	20F	-6.7C
8.7	10F	-12.2C
8.5	0F	-17.8C

I. If the measured battery voltage is below the minimum voltage shown in the table, replace the battery. If the measured voltage is at or above the minimum voltage shown in the table, return the battery to service.

## Battery Charging

To minimize possible damage to the battery and to allow the battery to be fully charged, the slow charging method is presented here. This charging method can be accomplished with a constant current battery charger which is available in most shops.

 <span style="font-size: 24pt; font-weight: bold; margin-left: 10px;">CAUTION</span>
<p><b>Follow the battery charger manufacturer's instructions when using a battery charger.</b></p>

**NOTE:** Using specific gravity of the battery cells is the most accurate method of determining battery condition.

1. If battery filler caps are removable, check the electrolyte level in each cell. If the level is below the tops of the plates in any cell, fill all cells with **distilled** water so that plates are just covered with electrolyte.
2. Determine the battery charge level from either its open circuit voltage or specific gravity (if filler caps are removable).

Battery Charge Level	Open Circuit Voltage	Specific Gravity
100%	12.68	1.265
75%	12.45	1.225
50%	12.24	1.190
25%	12.06	1.155
0%	11.89	1.120

3. Determine the charging time and rate **using the battery charger manufacturer's instructions** or the following table.

Battery Reserve Capacity (Minutes)	Battery Charge Level (Percent of Fully Charged)			
	75%	50%	25%	0%
<b>80 or less</b>	<b>3.8 hrs @ 3 amps</b>	<b>7.5 hrs @ 3 amps</b>	<b>11.3 hrs @ 3 amps</b>	<b>15 hrs @ 3 amps</b>
81 to 125	5.3 hrs @ 4 amps	10.5 hrs @ 4 amps	15.8 hrs @ 4 amps	21 hrs @ 4 amps
126 to 170	5.5 hrs @ 5 amps	11 hrs @ 5 amps	16.5 hrs @ 5 amps	22 hrs @ 5 amps
171 to 250	5.8 hrs @ 6 amps	11.5 hrs @ 6 amps	17.3 hrs @ 6 amps	23 hrs @ 6 amps
above 250	6 hrs @ 10 amps	12 hrs @ 10 amps	18 hrs @ 10 amps	24 hrs @ 10 amps

 <span style="font-size: 24pt; font-weight: bold; margin-left: 10px;">CAUTION</span>
<p><b>Do not charge a frozen battery because it can explode and cause injury. Let the battery warm to 60F (15.5C) before connecting to a charger.</b></p> <p><b>Charge the battery in a well-ventilated place to dissipate gases produced from charging. These gases are explosive; keep open flame and electrical spark away from the battery. Do not smoke. Nausea may result if the gases are inhaled. Unplug the charger from the electrical outlet before connecting or disconnecting the charger leads from the battery posts.</b></p>

4. **Following the battery charger manufacturer's instructions**, connect the charger cables to the battery. Make sure a good connection is made.
5. Charge the battery **following the battery charger manufacturer's instructions**.
6. Occasionally check the temperature of the battery electrolyte. If the temperature exceeds 125F (51.6C) or the electrolyte is violently gassing or spewing, the charging rate must be lowered or temporarily stopped.
7. Three hours prior to the end of the charging, measure the specific gravity of a battery cell once per hour. The battery is fully charged when the cells are gassing freely at a low charging rate and there is less than a 0.003 change in specific gravity for three consecutive readings.
8. If battery filler caps are removable, check the electrolyte level in each cell. Adjust electrolyte level if needed.

## Headlights



### CAUTION

The Workman headlights use a halogen bulb that becomes extremely hot when in operation. Handling a hot headlight bulb can cause severe burns and personal injury. Allow enough time for bulb to cool before handling.



### CAUTION

Any surface contamination can damage the headlight bulb and lead to its failure or explosion creating a serious safety hazard.

Headlight bulbs should be handled without touching the clear bulb surface. Handle the bulb by holding onto the base.

### Headlight Disassembly (Fig. 50)

1. Park machine on a level surface, stop engine, apply parking brake and remove key from ignition switch.
2. Remove hood (see Hood Removal in Chapter 7 – Chassis).
3. If bulb removal is necessary, loosen the bulb from the headlight by rotating it 1/4 turn counter-clockwise. Then, grasp bulb base and remove bulb from the headlight.
4. If necessary, remove headlight from hood.
  - A. Remove three (3) clips that secure headlight to hood.
  - B. Remove headlight from hood.

### Headlight Assembly

1. If headlight was removed, secure headlight to hood:
  - A. Insert headlight into hood opening. Make sure that logo on headlight lens is at bottom.
  - B. Secure headlight to hood with three (3) clips.
2. If bulb was removed from headlight, align tabs on bulb with notches in headlight opening. Insert bulb into back of headlight without touching the clear bulb surface. Secure bulb to headlight by rotating it 1/4 turn clockwise.

3. Install hood (see Hood Installation in Chapter 7 – Chassis). Make sure to connect the wire harness connector to the headlight during hood installation.

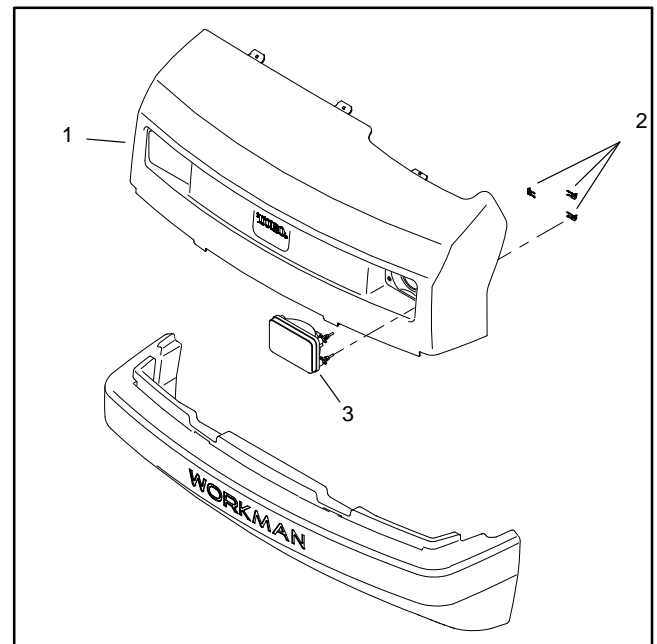

Figure 50

1. Front hood
2. Clips (3 per light)
3. Headlight (2)

## Tail Lamps

Disassemble and assemble tail lamp as necessary Fig. 51).

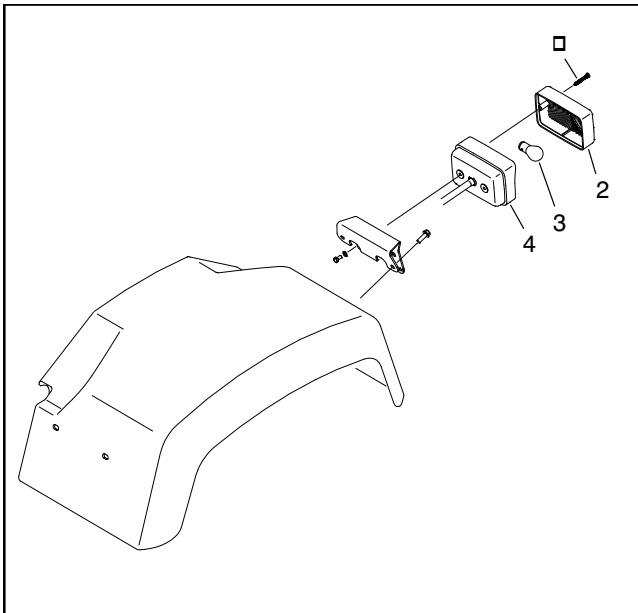

Figure 51

- 1. Screw (2)
- 2. Lens
- 3. Bulb
- 4. Base



# Hydraulic System

## Table of Contents

SPECIFICATIONS .....	3	SERVICE and REPAIRS .....	37
GENERAL INFORMATION .....	4	General Precautions for Removing and Installing	
Operator's Manual .....	4	Hydraulic System Components .....	37
Hydraulic Hoses .....	4	Check Hydraulic Lines and Hoses .....	37
Hydraulic Hose and Tube Installation .....	5	Primary Hydraulic System Gear Pump	
Hydraulic Fitting Installation .....	6	(Workman HDX and HDX-D) .....	38
SPECIAL TOOLS .....	8	Primary Hydraulic System Gear Pump	
HYDRAULIC SCHEMATICS .....	10	(Workman HD) .....	40
Primary Hydraulic System Schematic .....	10	Primary Hydraulic System Gear Pump	
High Flow Hydraulic System Schematic .....	11	Service .....	42
HYDRAULIC CIRCUIT OPERATION .....	12	High Flow hydraulic System Gear Pump	
Steering Circuit .....	12	Service .....	46
Raise and Lower Bed .....	13	Lift Valve .....	48
High Flow Hydraulic Circuit .....	14	Lift Valve Service .....	50
TROUBLESHOOTING .....	15	Steering Control Valve .....	52
TESTING .....	18	Steering Control Valve Service .....	54
Primary Hydraulic System Gear Pump Flow Test		Steering Cylinder .....	56
(Workman HDX and HDX-D) .....	20	Steering Cylinder Service .....	58
Primary Hydraulic System Gear Pump Flow Test		Lift Cylinder .....	60
(Workman HD) .....	24	Lift Cylinder Service .....	62
Primary Hydraulic System Relief Valve		Hydraulic Manifold (High Flow Hydraulics Kit) ...	64
Pressure Test .....	28	SAUER/DANFOSS STEERING UNIT TYPE OSPM	
Steering Control Valve and Steering		SERVICE MANUAL	
Cylinder Test .....	30		
Lift Cylinder Internal Leakage Test .....	32		
High Flow Hydraulics System			
Gear Pump Flow and Relief Pressure Tests ...	34		

This page is intentionally left blank.

# Specifications

**NOTE:** Vehicles that are equipped with the High Flow Hydraulics Kit have two (2) independent hydraulic systems. Each of these hydraulic systems include a hydraulic gear pump, reservoir, oil filter and controls. Maintenance, troubleshooting and repair of each hydraulic system need to be performed independently.

Item	Description
Workman HD Hydraulic Pump Primary System (drive section) displacement (per rev.)	Positive displacement gear type pump 0.378 in <sup>3</sup> (6.2 cc)
Workman HDX & HDX-D Hydraulic Pump Primary System (drive section) displacement (per rev.)	Positive displacement gear type pump 0.325 in <sup>3</sup> (5.3 cc)
Workman HDX & HDX-D Hydraulic Pump High Flow Hydraulic System (end section) displacement (per rev.)	Positive displacement gear type pump 0.519 in <sup>3</sup> (8.5 cc)
Primary System Relief Pressure	1800 PSI (124 Bar)
High Flow Hydraulic System Relief Pressure	2000 PSI (137 Bar)
Steering Control Valve	Eaton Steering Unit, Series OSPM
Steering Cylinder	2WD: Bore = 1-5/8" (41.3 mm), Stroke = 6-1/8" (15.6 cm) 4WD: Bore = 1-5/8" (41.3 mm), Stroke = 4-11/16" (11.9 cm)
Lift Control Valve	Three position control valve Spring return to neutral Ball checks to maintain load
Lift Cylinder	Bore = 1.5" (38 mm), Stroke = 16.25" (41.3)
Primary System Hydraulic/Transaxle Oil	Dextron III ATF
High Flow Hydraulic System Hydraulic Oil	High Viscosity Index/Low Pour Point Anti-wear Hydraulic Fluid, ISO VG 46
Primary System Capacity (transaxle)	7.5 U.S. quart (7.1 Liter)
High Flow Hydraulic System Capacity (reservoir)	4 U.S. gallon (15 Liter)
Primary System Filter	Automotive, 10 micron spin-on cartridge type 25 PSI by-pass valve 100 mesh strainer in transaxle
High Flow Hydraulic System Filter	Automotive, 10 micron spin-on cartridge type 25 PSI by-pass valve 100 mesh strainer in reservoir

# General Information

---

## Operator's Manual

The Operator's Manual provides information regarding the operation, general maintenance and maintenance intervals for your Workman vehicle. Refer to the Operator's Manual for additional information when servicing the vehicle.

---

## Hydraulic Hoses

Hydraulic hoses are subject to extreme conditions such as pressure differentials during operation and exposure to weather, sun, chemicals, very warm storage conditions or mishandling during operation and maintenance. These conditions can cause hose damage and deterioration. Some hoses are more susceptible to these conditions than others. Inspect all machine hydraulic hoses frequently for signs of deterioration or damage:

Hard, cracked, cut, abraded, charred, leaking or otherwise damaged hose.

Kinked, crushed, flattened or twisted hose.

Blistered, soft, degraded or loose hose cover.

Cracked, damaged or badly corroded hose fittings.

When replacing a hydraulic hose, be sure that the hose is straight (not twisted) before tightening the fittings. This can be done by observing the imprint (lay-line) on the hose. Use two wrenches; hold the hose straight with one wrench and tighten the hose swivel nut onto the fitting with the other wrench (See Hydraulic Hose and Tube Installation in this section). If the hose has an elbow at one end, tighten the swivel nut on that end before tightening the nut on the straight end of the hose.

For additional hydraulic hose information, refer to Toro Service Training Book, Hydraulic Hose Servicing (Part Number 94813SL).



## WARNING

**Before disconnecting or performing any work on hydraulic system, relieve all pressure in system (see Relieving Hydraulic System Pressure in this section).**

**Keep body and hands away from pin hole leaks or nozzles that eject hydraulic fluid under high pressure. Use paper or cardboard, not hands, to search for leaks. Hydraulic fluid escaping under pressure can have sufficient force to penetrate the skin and cause serious injury. If fluid is injected into the skin, it must be surgically removed within a few hours by a doctor familiar with this type of injury. Gangrene may result from such an injury.**



## Hydraulic Hose and Tube Installation (O-Ring Face Seal Fitting)

1. Make sure threads and sealing surfaces of the hose/ tube and the fitting are free of burrs, nicks, scratches or any foreign material.

2. As a preventative measure against leakage, it is recommended that the face seal O-ring be replaced any time the connection is opened. Make sure the O-ring is installed and properly seated in the fitting groove. Lightly lubricate the O-ring with clean hydraulic oil.

3. Place the hose/tube against the fitting body so that the flat face of the hose/tube sleeve fully contacts the O-ring in the fitting.

4. Thread the swivel nut onto the fitting by hand. While holding the hose/tube with a wrench, use a torque wrench to tighten the swivel nut to the recommended installation torque (Fig. 3). This tightening process will require the use of an offset wrench (e.g. crowfoot wrench). Use of an offset wrench will affect torque wrench calibration due to the effective length change of the torque wrench. Tightening torque when using a torque wrench with an offset wrench will be lower than the listed installation torque (see Using a Torque Wrench with an Offset Wrench in the Torque Specifications section of Chapter 2 – Product Records and Maintenance).

5. If a torque wrench is not available or if space at the swivel nut prevents use of a torque wrench, an alternate method of assembly is the Flats From Wrench Resistance (F.F.W.R.) method (Fig. 2).

A. Using a wrench, tighten the swivel nut onto the fitting until light wrench resistance is reached (approximately 30 in-lb).

B. Mark the swivel nut and fitting body. Hold the hose/tube with a wrench to prevent it from turning.

C. Use a second wrench to tighten the nut to the correct Flats From Wrench Resistance (F.F.W.R.). The markings on the nut and fitting body will verify that the connection has been properly tightened.

Size	F.F.W.R.
4 (1/4 in. nominal hose or tubing)	1/2 to 3/4
6 (3/8 in.)	1/2 to 3/4
8 (1/2 in.)	1/2 to 3/4
10 (5/8 in.)	1/2 to 3/4
12 (3/4 in.)	1/3 to 1/2
16 (1 in.)	1/3 to 1/2

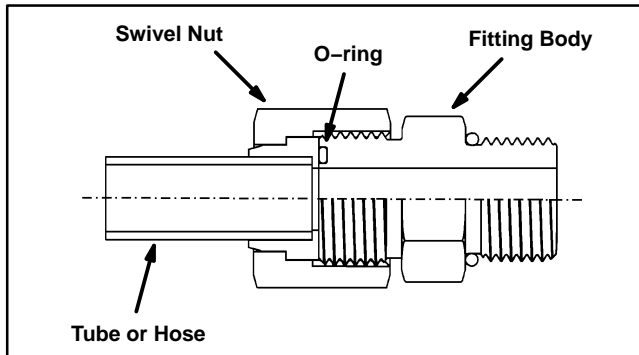

Figure 1

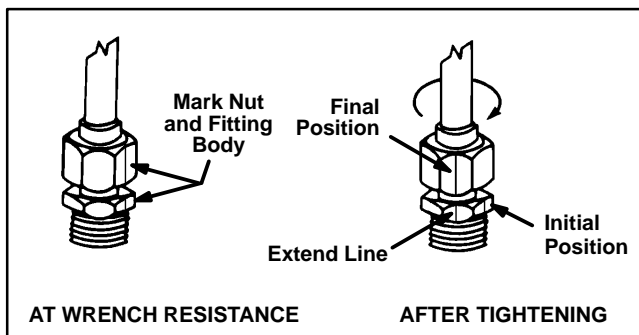

Figure 2

Fitting Dash Size	Hose/Tube Side Thread Size	Installation Torque
4	9/16 – 18	18 to 22 ft-lb (25 to 29 N-m)
6	11/16 – 16	27 to 33 ft-lb (37 to 44 N-m)
8	13/16 – 16	37 to 47 ft-lb (51 to 63 N-m)
10	1 – 14	60 to 74 ft-lb (82 to 100 N-m)
12	1 3/16 – 12	85 to 105 ft-lb (116 to 142 N-m)
16	1 7/16 – 12	110 to 136 ft-lb (150 to 184 N-m)
20	1 11/16 – 12	140 to 172 ft-lb (190 to 233 N-m)

Figure 3

## Hydraulic Fitting Installation (SAE Straight Thread O-Ring Fitting into Component Port)

### Non-Adjustable Fitting (Fig. 4)

1. Make sure all threads and sealing surfaces of fitting and component port are free of burrs, nicks, scratches or any foreign material.
2. As a preventative measure against leakage, it is recommended that the O-ring be replaced any time the connection is opened.
3. Lightly lubricate the O-ring with clean hydraulic oil. Fitting threads should be clean with no lubricant applied.

**IMPORTANT: Before installing fitting into port, determine port material. If fitting is to be installed into an aluminum port, installation torque is reduced.**

4. Install the fitting into the port. Then, use a torque wrench and socket to tighten the fitting to the recommended installation torque (Fig. 5).

**NOTE:** Use of an offset wrench (e.g. crowfoot wrench) will affect torque wrench calibration due to the effective length change of the torque wrench. Tightening torque when using a torque wrench with an offset wrench will be less than the recommended installation torque. See Using a Torque Wrench with an Offset Wrench in the Torque Specifications section of Chapter 2 – Product Records and Maintenance to determine necessary conversion information.

5. If a torque wrench is not available, or if space at the port prevents use of a torque wrench, an alternate method of assembly is the Flats From Finger Tight (F.F.F.T.) method.

A. Install the fitting into the port and tighten it down full length until finger tight.

B. If port material is steel, tighten the fitting to the listed F.F.F.T. If port material is aluminum, tighten fitting to 60% of listed F.F.F.T.

Size	F.F.F.T.
4 (1/4 in. nominal hose or tubing)	1.00 ± 0.25
6 (3/8 in.)	1.50 ± 0.25
8 (1/2 in.)	1.50 ± 0.25
10 (5/8 in.)	1.50 ± 0.25
12 (3/4 in.)	1.50 ± 0.25
16 (1 in.)	1.50 ± 0.25

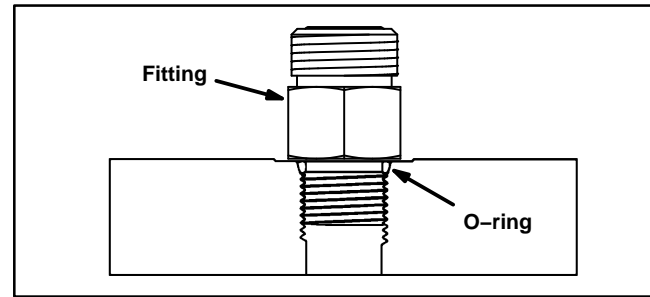

Figure 4

Fitting Dash Size	Fitting Port Side Thread Size	Installation Torque Into Steel Port	Installation Torque Into Aluminum Port
4	7/16 – 20	15 to 19 ft-lb (21 to 25 N-m)	9 to 11 ft-lb (13 to 15 N-m)
5	1/2 – 20	18 to 22 ft-lb (25 to 29 N-m)	11 to 15 ft-lb (15 to 20 N-m)
6	9/16 – 18	34 to 42 ft-lb (47 to 56 N-m)	20 to 26 ft-lb (28 to 35 N-m)
8	3/4 – 16	58 to 72 ft-lb (79 to 97 N-m)	35 to 43 ft-lb (48 to 58 N-m)
10	7/8 – 14	99 to 121 ft-lb (135 to 164 N-m)	60 to 74 ft-lb (82 to 100 N-m)
12	1 1/16 – 12	134 to 164 ft-lb (182 to 222 N-m)	81 to 99 ft-lb (110 to 134 N-m)
14	1 3/16 – 12	160 to 196 ft-lb (217 to 265 N-m)	96 to 118 ft-lb (131 to 160 N-m)
16	1 5/16 – 12	202 to 248 ft-lb (274 to 336 N-m)	121 to 149 ft-lb (165 to 202 N-m)
20	1 5/8 – 12	247 to 303 ft-lb (335 to 410 N-m)	149 to 183 ft-lb (202 to 248 N-m)

Figure 5

**Adjustable Fitting (Fig. 6)**

1. Make sure all threads and sealing surfaces of fitting and component port are free of burrs, nicks, scratches or any foreign material.
2. As a preventative measure against leakage, it is recommended that the O-ring be replaced any time the connection is opened.
3. Lightly lubricate the O-ring with clean hydraulic oil. Fitting threads should be clean with no lubricant applied.
4. Turn back the lock nut as far as possible. Make sure the back up washer is not loose and is pushed up as far as possible (Step 1 in Fig. 7).

**IMPORTANT: Before installing fitting into port, determine port material. If fitting is to be installed into an aluminum port, installation torque is reduced.**

5. Install the fitting into the port and tighten finger tight until the washer contacts the face of the port (Step 2).
6. To put the fitting in the desired position, unscrew it by the required amount, but no more than one full turn (Step 3).
7. Hold the fitting in the desired position with a wrench and use a torque wrench to tighten the fitting to the recommended installation torque (Fig. 5). This tightening process will require the use of an offset wrench (e.g. crowfoot wrench). Use of an offset wrench will affect torque wrench calibration due to the effective length change of the torque wrench. Tightening torque when using a torque wrench with an offset wrench will be lower than the listed installation torque (see Using a Torque Wrench with an Offset Wrench in the Torque Specifications section of Chapter 2 – Product Records and Maintenance).
8. If a torque wrench is not available, or if space at the port prevents use of a torque wrench, an alternate method of assembly is the Flats From Finger Tight (F.F.F.T.) method. Hold the fitting in the desired position with a wrench and, if port material is steel, tighten the lock nut with a second wrench to the listed F.F.F.T (Step 4). If port material is aluminum, tighten fitting to 60% of listed F.F.F.T.

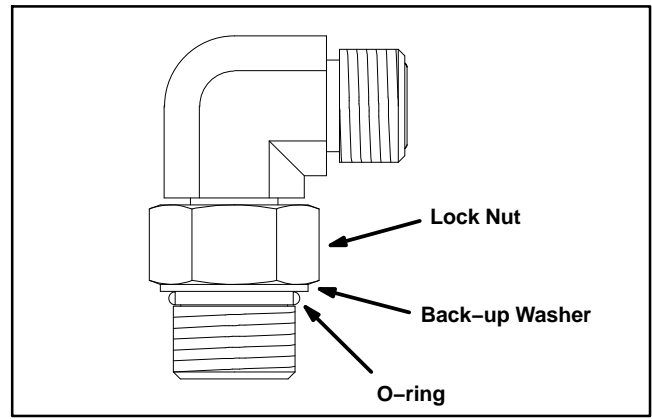

Figure 6

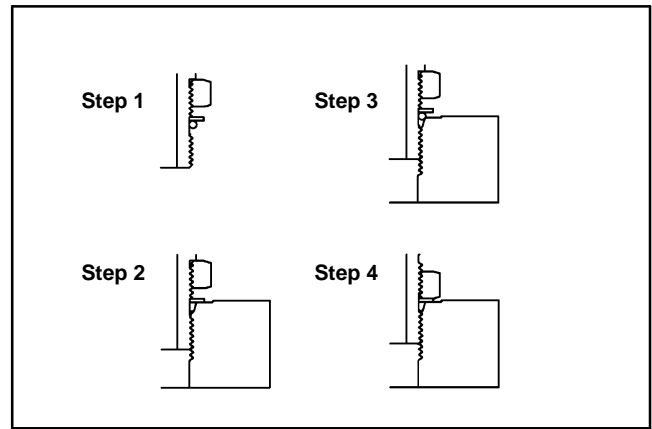

Figure 7

Size	F.F.F.T.
4 (1/4 in. nominal hose or tubing)	1.00 ± 0.25
6 (3/8 in.)	1.50 ± 0.25
8 (1/2 in.)	1.50 ± 0.25
10 (5/8 in.)	1.50 ± 0.25
12 (3/4 in.)	1.50 ± 0.25
16 (1 in.)	1.50 ± 0.25

# Special Tools

Order these special tools from your Toro Distributor.

---

## Hydraulic Pressure Test Kit

Use to take various pressure readings for diagnostic tests. Quick disconnect fittings provided attach directly to mating fittings on machine test ports without tools. A high pressure hose is provided for remote readings. Contains one each: 1000 PSI (70 Bar), 5000 PSI (350 Bar) and 10000 PSI (700 Bar) gauges. Use gauges as recommended in Testing section of this chapter.

Toro Part Number: **TOR47009**



Figure 8

---

## Hydraulic Tester (Pressure and Flow)

This tester requires O-ring Face Seal (ORFS) adapter fittings for use on this machine (see Hydraulic Test Fitting Kit (TOR4079) in this section).

1. **INLET HOSE:** Hose connected from the system circuit to the inlet side of the hydraulic tester.
2. **LOAD VALVE:** A simulated working load is created in the circuit by turning the valve to restrict flow.
3. **PRESSURE GAUGE:** 0 to 5000 PSI gauge to provide operating circuit pressure.
4. **FLOW METER:** This meter measures actual oil flow in the operating circuit with a gauge rated at 15 GPM.
5. **OUTLET HOSE:** A hose from the outlet side of the hydraulic tester connects to the hydraulic system circuit.

Toro Part Number: **TOR214678**



Figure 9

## Hydraulic Test Fitting Kit

This kit includes a variety of O-ring Face Seal fittings to enable you to connect test gauges into the system.

The kit includes: tee's, unions, reducers, plugs, caps and male test fittings.

Toro Part Number: **TOR4079**







TORO TEST FITTING KIT			
FITTING	TOOL NUMBER	FITTING	TOOL NUMBER
	Swivel Nut Run Tee (2 ea.) Size Toro No. No. 4 TOR4079-3 No. 6 TOR4079-12 No. 8 TOR4079-4 No. 10 TOR4079-5		Union (1 ea.) Size Toro No. No. 6 to No. 8 TOR4079-8 No. 10 to No. 8 TOR4079-2 No. 8 to No. 8 TOR4079-9
	Plug (2 ea.) Size Toro No. No. 4 TOR4079-13 No. 6 TOR4079-14 No. 8 TOR4079-15 No. 10 TOR4079-16		Reducer (1 ea.) Size Toro No. No. 10 to No. 8 TOR4079-7 No. 12 to No. 8 TOR4079-6
	Cap (2 ea.) Size Toro No. No. 4 TOR4079-17 No. 6 TOR4079-18 No. 8 TOR4079-19 No. 10 TOR4079-20		Test Cap Fitting (2 ea.) Size Toro No. No. 4 TOR4079-10 No. 6 TOR4079-11 No. 8 TOR4079-21 No. 10 TOR4079-1
			Test Fitting (2 ea.) Size Toro No. 7/16-20 ORB TOR4079-22 1/8" Pipe Thd. TOR4079-23

Figure 10

## O-ring Kit

The kit includes O-rings in a variety of sizes for face seal and port seal hydraulic connections. It is recommended that O-rings be replaced whenever a hydraulic connection is loosened.

Toro Part Number: **16-3799**



Figure 11

## Male Coupler (For High Flow Hydraulics Kit)

Male coupler that fits into the High Flow Hydraulics Kit female coupler. Male coupler can be used when testing hydraulic components of High Flow Kit. Two (2) couplers are required for testing.

Toro Part Number: **105-4170**

**NOTE:** Dust cap (part number 105-7963) for male coupler is available separately.

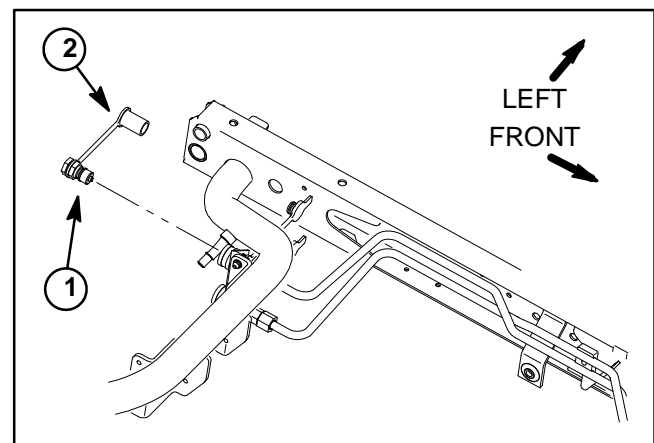
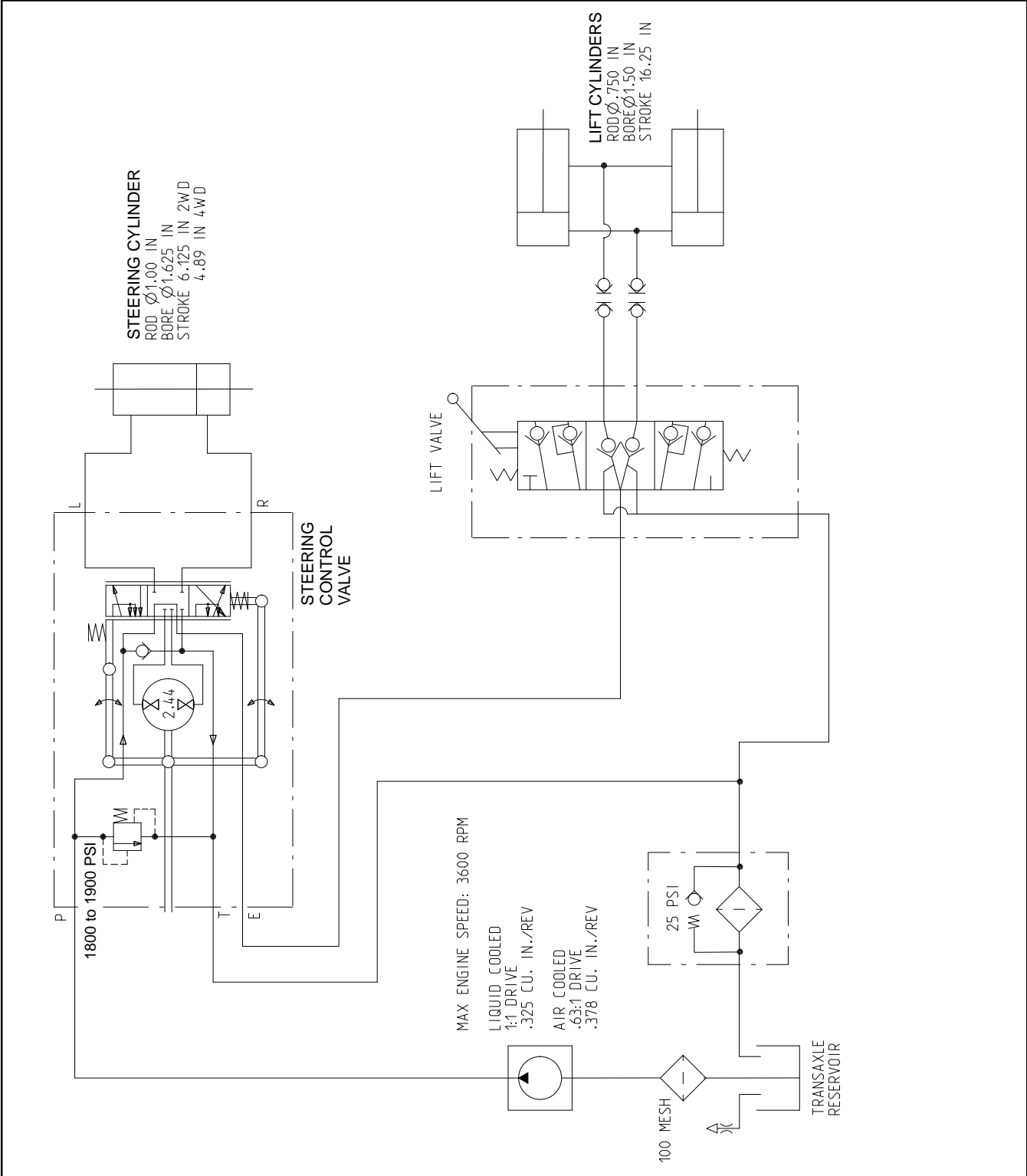

Figure 12

1. Male coupler
2. Dust cap

# Hydraulic Schematics

## Primary Hydraulic System Schematic



# High Flow Hydraulic System Schematic

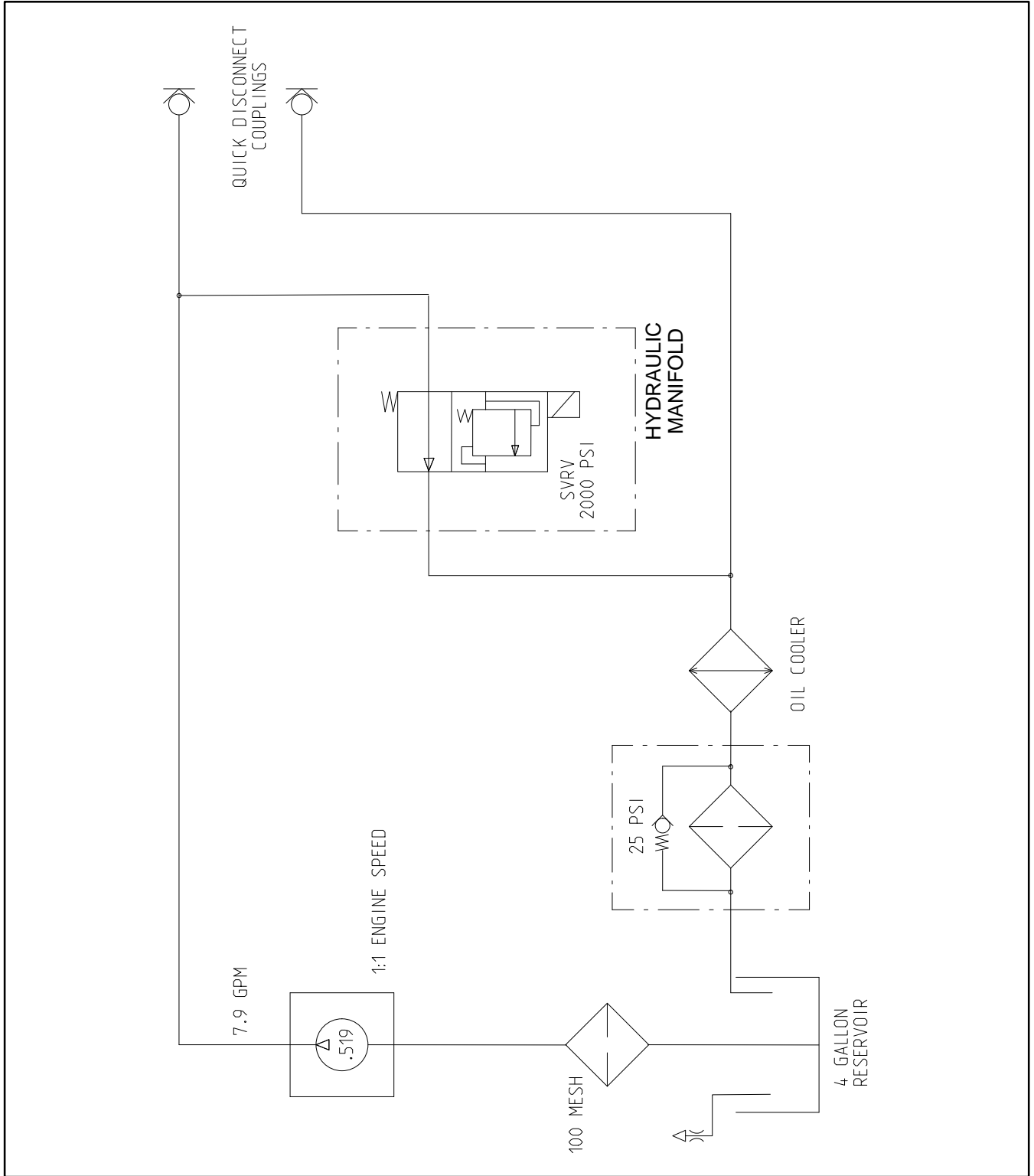

# Hydraulic Circuit Operation

## Steering Circuit

The hydraulic gear pump supplies flow for the steering circuit and for raising and lowering the bed. Pump output flows to the steering control valve before reaching the lift valve so the steering circuit has priority. Circuit pressure is limited by a relief valve located in the steering control valve.

When the steering wheel is not being turned with the engine running (hydraulic pump being rotated), flow enters the steering control valve at the P port and by-passes the rotary meter and steering cylinder. Flow leaves the control valve through the E port and is directed to the lift valve.

### Left Turn

When a left turn is made with the engine running, the turning of the steering wheel positions the spool valve so that flow goes through the top of the spool. Flow entering the steering control valve at the P port passes through the rotary meter and is directed out the L port. Pressure contracts the steering cylinder for a left turn. The rotary meter ensures that the oil flow to the cylinder is proportional to the amount of the turning on the steering wheel.

Fluid leaving the steering cylinder flows back through the spool valve, then out the T port and returns to the hydraulic reservoir (transaxle).

The steering wheel and steering control valve return to the neutral position when turning is completed.

### Right Turn

When a right turn is made with the engine running, the turning of the steering wheel positions the spool valve so that flow goes through the bottom of the spool. Flow entering the steering control valve at the P port passes through the rotary meter and is directed out port R. Pressure extends the steering cylinder for a right turn. The rotary meter ensures that the oil flow to the cylinder is proportional to the amount of the turning on the steering wheel. Fluid leaving the cylinder flows back through the spool valve, then out the T port and to the hydraulic reservoir (transaxle).

The steering wheel and steering control valve return to the neutral position when turning is completed.

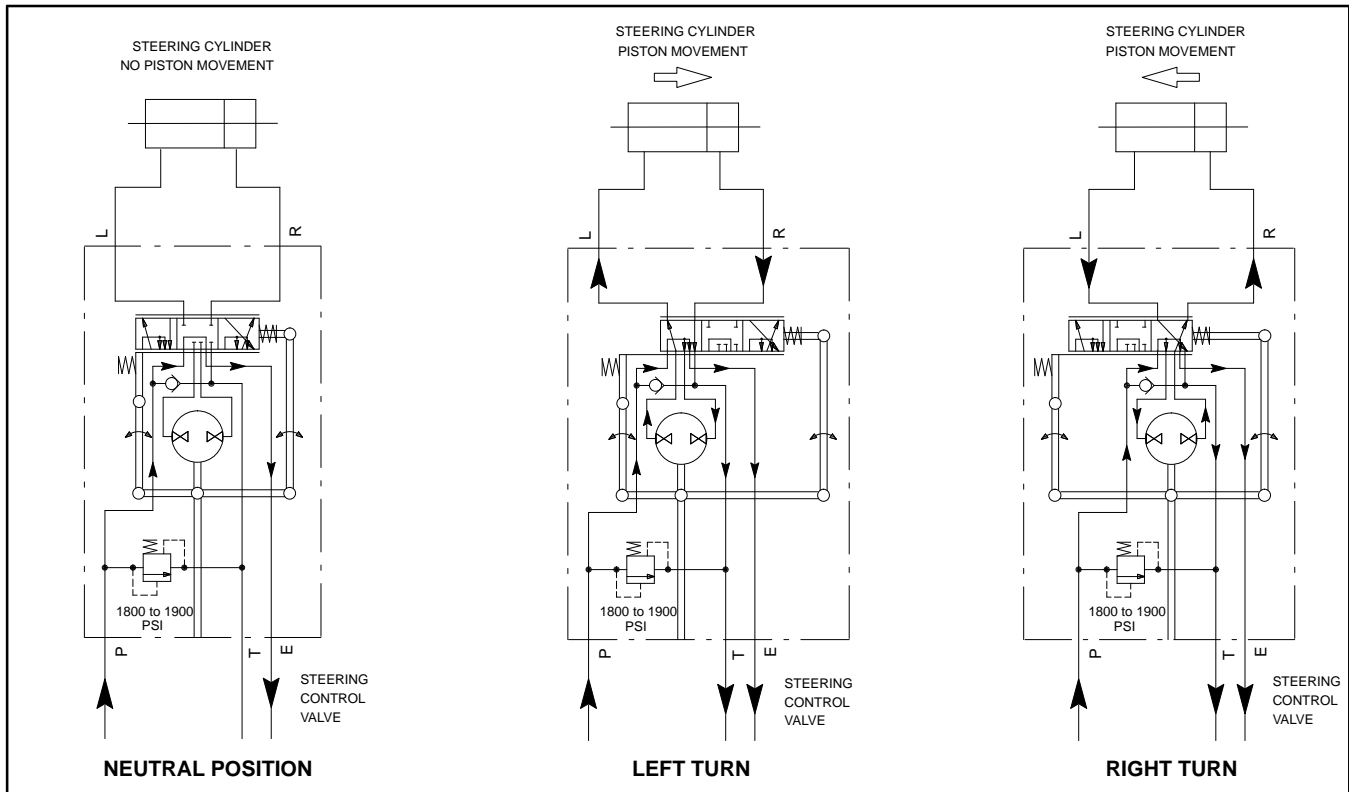

Figure 13



## Raise and Lower Bed

The hydraulic gear pump supplies flow for the steering circuit and for raising and lowering the bed. Pump output flows through the steering control valve and then to the lift valve for raising and lowering the bed (flow priority to the steering circuit). Circuit pressure is limited by a relief valve located in the steering control valve.

When the lift valve is in the center position, flow from the gear pump by-passes the lift valve and returns through the hydraulic oil filter and to the reservoir (transaxle).

### Raise Bed

When the bed is to be raised (lift lever pulled rearward), the lift valve spool directs flow out the A port of the lift valve to the barrel end of the lift cylinders. Hydraulic pressure against the cylinder pistons extends the cylinder shafts. At the same time, the pistons push the hydraulic fluid in the rod end of the lift cylinders out and through the lift valve to the reservoir (transaxle).

When the control valve lever is released, spring action returns the lift valve spool to the center position and lift cylinder movement is stopped. The cylinder position is locked in place since there is no complete circuit of flow to and from the lift cylinders.

### Lower Bed

Circuit operation for lowering the bed (lift lever pushed forward) is similar to raising the bed. However, the lift valve spool directs flow from the B port of the lift valve to the rod end of the lift cylinders. Hydraulic pressure against the cylinder pistons retracts the cylinder shafts to lower the bed.

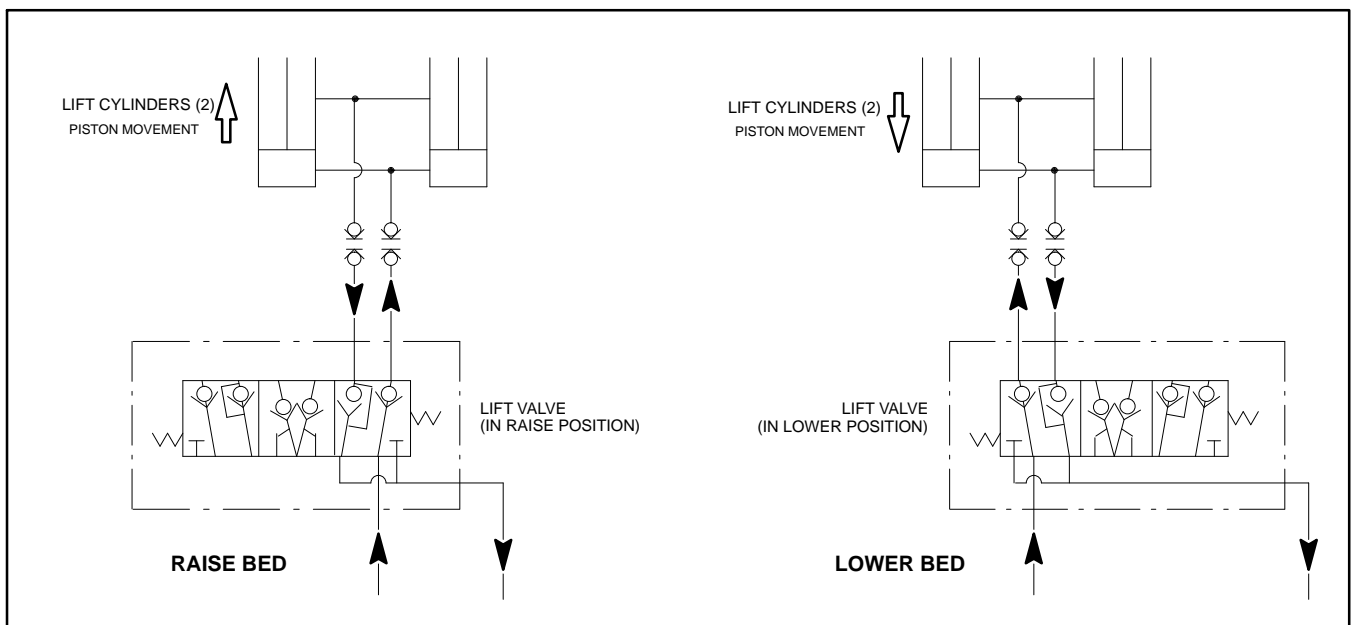

Figure 14

## High Flow Hydraulic Circuit

On Workman HDX and HDX-D vehicles that are equipped with the high flow hydraulics kit, a second gear pump is directly coupled to the standard gear pump. This second gear pump provides hydraulic system flow for the high flow circuit that is designed to power hydraulic attachments. A manifold equipped with a solenoid operated relief valve (SVRV) is used to control the circuit and when energized, also provides circuit relief. A dash mounted rocker switch is used to energize the solenoid to engage the circuit. The high flow circuit includes quick disconnect couplers for attachment connection, a reservoir, a hydraulic filter and an oil cooler.

### High Flow Circuit OFF

When the rocker switch is in the OFF position, the manifold solenoid operated relief valve (SVRV) is not energized. Flow from the gear pump is routed through the manifold, the oil cooler, the oil filter and then returns to the reservoir.

### High Flow Circuit ON (Fig. 15)

When the rocker switch is in the ON position, the manifold solenoid operated relief valve (SVRV) is energized. The energized solenoid valve directs gear pump oil flow to the hydraulic attachment. Circuit pressure is limited to 2000 PSI (138 bar) by the manifold solenoid relief valve (SVRV). Return oil from the attachment is routed through the oil cooler, the oil filter and then returns to the reservoir.

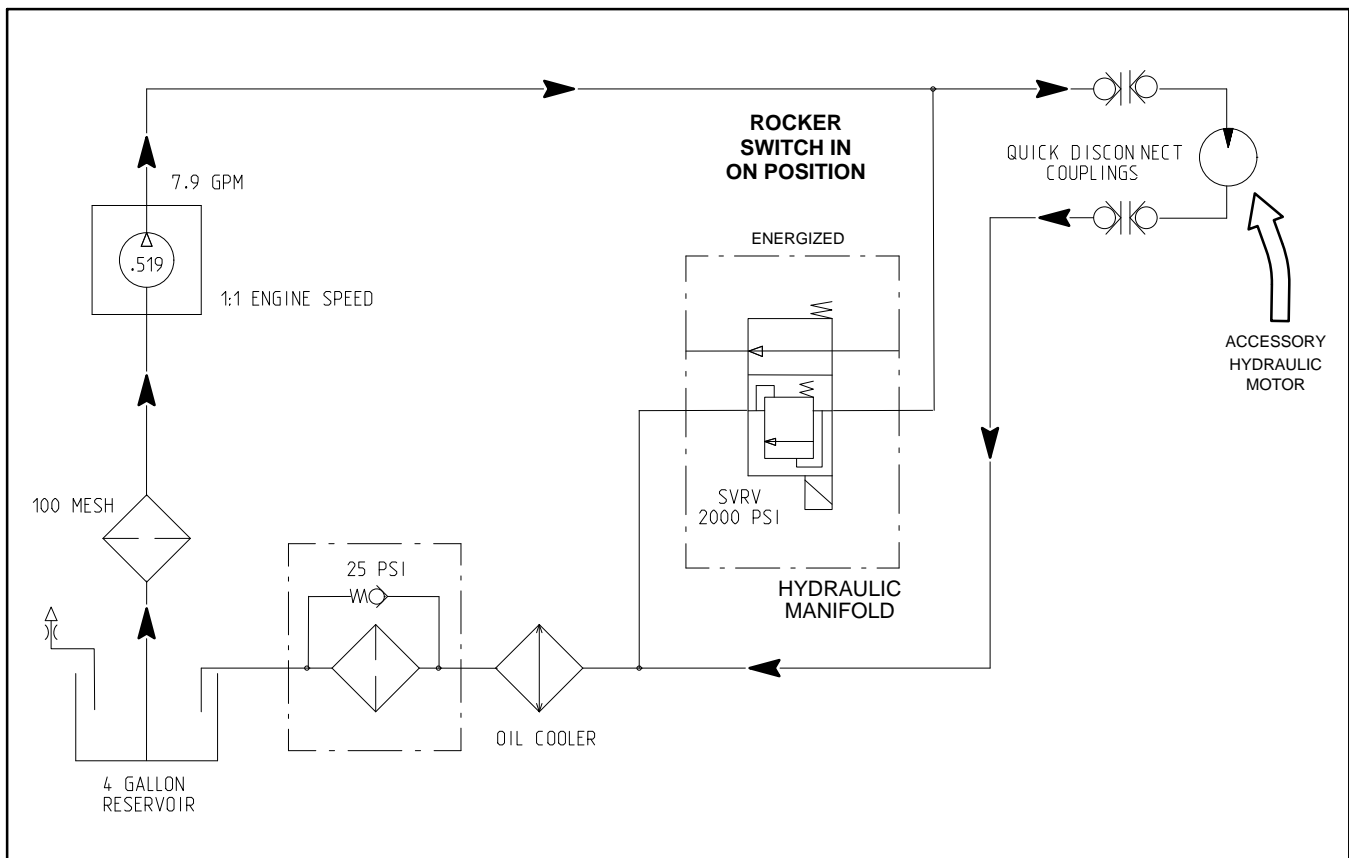

Figure 15

# Troubleshooting

The cause of an improperly functioning hydraulic system is best diagnosed with the use of proper testing equipment and a thorough understanding of the complete hydraulic system.

A hydraulic system with an excessive increase in heat or noise is a potential failure. Should either of these conditions be noticed, immediately stop the vehicle, turn off the engine, locate the cause of the trouble and correct it before allowing the vehicle to be used again. Contin-

ued use of an improperly functioning hydraulic system could lead to extensive internal component damage.

The charts that follow contain information to assist in troubleshooting. There may possibly be more than one cause for a vehicle malfunction.

Refer to the Testing section of this Chapter for precautions and specific test procedures.

<b>Problem</b>	<b>Possible Cause</b>
Hydraulic oil leaks.	Hydraulic fitting(s), hose(s) or tube(s) are loose or damaged.  O-ring(s) or seal(s) are missing or damaged.
Squealing noise.	Hydraulic lift valve is being held in raise or lower position (hydraulic oil flowing over relief valve).
Hydraulic oil is overheating.	Oil level in transaxle is incorrect.  Hydraulic oil is contaminated.  Incorrect oil in system (see oil recommendations in Operator's Manual).  Hydraulic hose or tubing is kinked or severely bent.  Hydraulic oil is going over relief valve excessively (e.g. too heavy a load on hydraulic system or quick coupler disconnected with lift valve engaged).  Suction screen in transaxle is loose or clogged.  Hydraulic gear pump is worn or damaged (NOTE: Entire hydraulic system is affected).  Transaxle or drive train problem (see Drive Train – Chapter 7).
Lift cylinders extend with lift valve in neutral position.	Load checks in hydraulic lift valve are leaking.  Lift valve lever is sticking.  Lift valve control handle is not in correct location.  Hydraulic relief valve is stuck or damaged (see Gear Pump Flow and System Relief Pressure Test in this chapter).
Bed drops from raised position with lift valve in centered position.	Improperly positioned lift valve lever.  Lift valve is worn or damaged.  Lift cylinder(s) is (are) leaking externally.  Lift cylinder hydraulic lines or fittings are leaking.

Problem	Possible Cause
<p>Bed does not lift or lifts very slowly.</p>	<p>Excessive load in bed.</p> <p>Oil level in transaxle is low.</p> <p>Engine RPM is low.</p> <p>Incorrect oil in system (see oil recommendations in Operator's Manual).</p> <p>Lift cylinder pivots or bed pivots are binding or damaged.</p> <p>Hydraulic pump drive belt is loose (Workman HD vehicles).</p> <p>Lift cylinder(s) is (are) worn or damaged.</p> <p>Gear pump key is sheared or missing (NOTE: Entire hydraulic system is affected).</p> <p>Woodruff key on drive pulley is sheared or missing (Workman HD vehicles) (NOTE: Entire hydraulic system is affected).</p> <p>Gear pump flow or pressure is low (see Gear Pump Flow and System Relief Pressure Test in this chapter) (NOTE: Entire hydraulic system is affected).</p>
<p>Steering inoperative or sluggish</p> <p>NOTE: On a smooth surface with a heavily loaded, stationary vehicle, hydraulic circuit pressure to steering control valve may be near relief pressure.</p>	<p>Engine RPM is low.</p> <p>Oil level in transaxle is low.</p> <p>Steering components (e.g. pitman arm, tie rods, steering cylinder rod ends) are worn or binding.</p> <p>Hydraulic pump drive belt is loose (Workman HD vehicles) (NOTE: Entire hydraulic system is affected).</p> <p>Steering cylinder is binding.</p> <p>Hydraulic relief valve is stuck or damaged (see Gear Pump Flow and System Relief Pressure Test in the Testing section).</p> <p>Steering control valve is worn or damaged.</p> <p>Gear pump key is sheared or missing (NOTE: Entire hydraulic system is affected).</p> <p>Woodruff key on drive pulley is sheared or missing (Workman HD vehicles) (NOTE: Entire hydraulic system is affected).</p> <p>Steering cylinder leaks internally.</p> <p>Gear pump flow or pressure is low (see Gear Pump Flow and System Relief Pressure Test in the Testing section) (NOTE: Entire hydraulic system is affected).</p> <p>Gear pump is worn or damaged (NOTE: Entire hydraulic system is affected).</p>

Problem	Possible Cause
Difficulty in connecting or disconnecting quick couplers.	<p>Hydraulic pressure is not relieved (coupler under pressure – engine running).</p> <p>Hydraulic lift valve is not in neutral (centered) position.</p>
Hydraulic attachment does not function.	<p>Quick couplers are not fully engaged.</p> <p>Quick couplers are interchanged.</p> <p>Oil level in transaxle is low.</p> <p>Engine RPM is low.</p> <p>Excessive load is applied to attachment.</p> <p>Hydraulic pump drive belt is loose (Workman HD vehicles) (NOTE: Entire hydraulic system is affected).</p> <p>Gear pump key is sheared or missing (NOTE: Entire hydraulic system is affected).</p> <p>Woodruff key on drive pulley is sheared or missing (Workman HD vehicles) (NOTE: Entire hydraulic system is affected).</p> <p>Gear pump flow or pressure is low (see Gear Pump Flow and System Relief Pressure Test in this chapter).</p> <p>Hydraulic relief valve is stuck or damaged (see Gear Pump Flow and System Relief Pressure Test in this chapter).</p> <p>Hydraulic lift valve is worn or damaged.</p> <p>Hydraulic component(s) on attachment is malfunctioning or damaged.</p>

# Testing

The most effective method for isolating problems in the hydraulic system is by using hydraulic test equipment such as pressure gauges and flow meters in the circuits during various operational checks (see Special Tools section in this Chapter).



## CAUTION

Failure to use gauge with recommended pressure (psi/bar) rating as listed in test procedures could result in damage to gauge and possible personal injury from leaking hot oil.

### Before Performing Hydraulic Tests

All obvious areas such as oil supply, filter, binding linkage, loose fasteners or improper adjustments must be checked before assuming that a hydraulic component is the source of the problem being experienced.

### Precautions For Hydraulic Testing



## WARNING

Before disconnecting or performing any work on the hydraulic system, all pressure in the system must be relieved by stopping the engine, rotating the steering wheel in both directions, lowering or supporting the bed and operating other hydraulic accessories.

Keep body and hands away from pin hole leaks or nozzles that eject hydraulic fluid under high pressure. Use paper or cardboard, not hands, to search for leaks. Hydraulic fluid escaping under pressure can have sufficient force to penetrate skin and cause serious injury. If fluid is injected into the skin, it must be surgically removed within a few hours by a doctor familiar with this type of injury. Gangrene may result from such an injury.



## CAUTION

All testing should be performed by two (2) people. One person should be in the seat to operate the machine and the other should read and record test results.

1. Thoroughly clean the vehicle before disconnecting or disassembling any hydraulic components. Always keep in mind the need for cleanliness when working on hydraulic equipment. Contamination will cause excessive wear of hydraulic components.

2. Review all test steps before starting the test procedure.

3. Put metal caps or plugs on any hydraulic lines left open or exposed during testing or removal of components.

4. The engine must be in good operating condition. Use a phototach (non-contact tachometer) when performing a hydraulic test. Engine speed can affect the accuracy of the test readings. Monitor engine RPM during hydraulic testing. Use the information below when performing hydraulic system tests. If engine RPM is above or below the specified speed during a test, you will need to adjust the expected hydraulic performance parameters (aprox. 3% per 100 engine rpm at full throttle)

**IMPORTANT: Hydraulic component output volume relates directly to engine RPM. For every 100 engine rpm the following component output volumes will change by the volume listed.**

Primary Hydraulic System Gear Pump: 100 engine RPM = 0.14 GPM or 18 oz. (532 cc) of hydraulic fluid displaced per minute for Workman HDX and HDX-D units and 100 engine RPM = 0.16 GPM or 21 oz. (619 cc) of hydraulic fluid displaced per minute for Workman HD units.

High Flow Hydraulic System Gear Pump (if equipped): 100 engine RPM = 0.22 GPM or 28.7 oz. (850 cc) of hydraulic fluid displaced per minute

**NOTE:** Engine-to-Pump ratio is 1:1 for Workman HDX and HDX-D units and 1:0.63 for Workman HD units. In other words, 1 engine RPM = 1 pump RPM for Workman HDX and HDX-D units and 1 engine RPM = 0.63 pump RPM for Workman HD units.

5. On Workman HD vehicles, the hydraulic gear pump is belt driven. Before performing any hydraulic test on Workman HD vehicles, check for proper gear pump drive belt adjustment.

6. To prevent damage to tester or components when using tester with pressure and flow capabilities, the inlet and the outlet hoses must be properly connected and not reversed.

7. To minimize the possibility of damaging components when using tester with pressure and flow capabilities, completely open load valve in hydraulic tester before starting engine.

8. Install fittings finger tight, far enough to insure that they are not cross-threaded, before tightening the fittings with a wrench.

9. Position the tester hoses so that rotating vehicle parts will not make contact with them and result in hose or tester damage.

10. Check and adjust the oil level in the hydraulic reservoir after connecting hydraulic test equipment.

11. All hydraulic tests should be made with the hydraulic oil at normal operating temperature.

12. After testing is completed, check and adjust the oil level in the hydraulic reservoir before returning the vehicle to service.

**Primary Hydraulic System Gear Pump Flow Test  
(Workman HDX and HDX-D)**

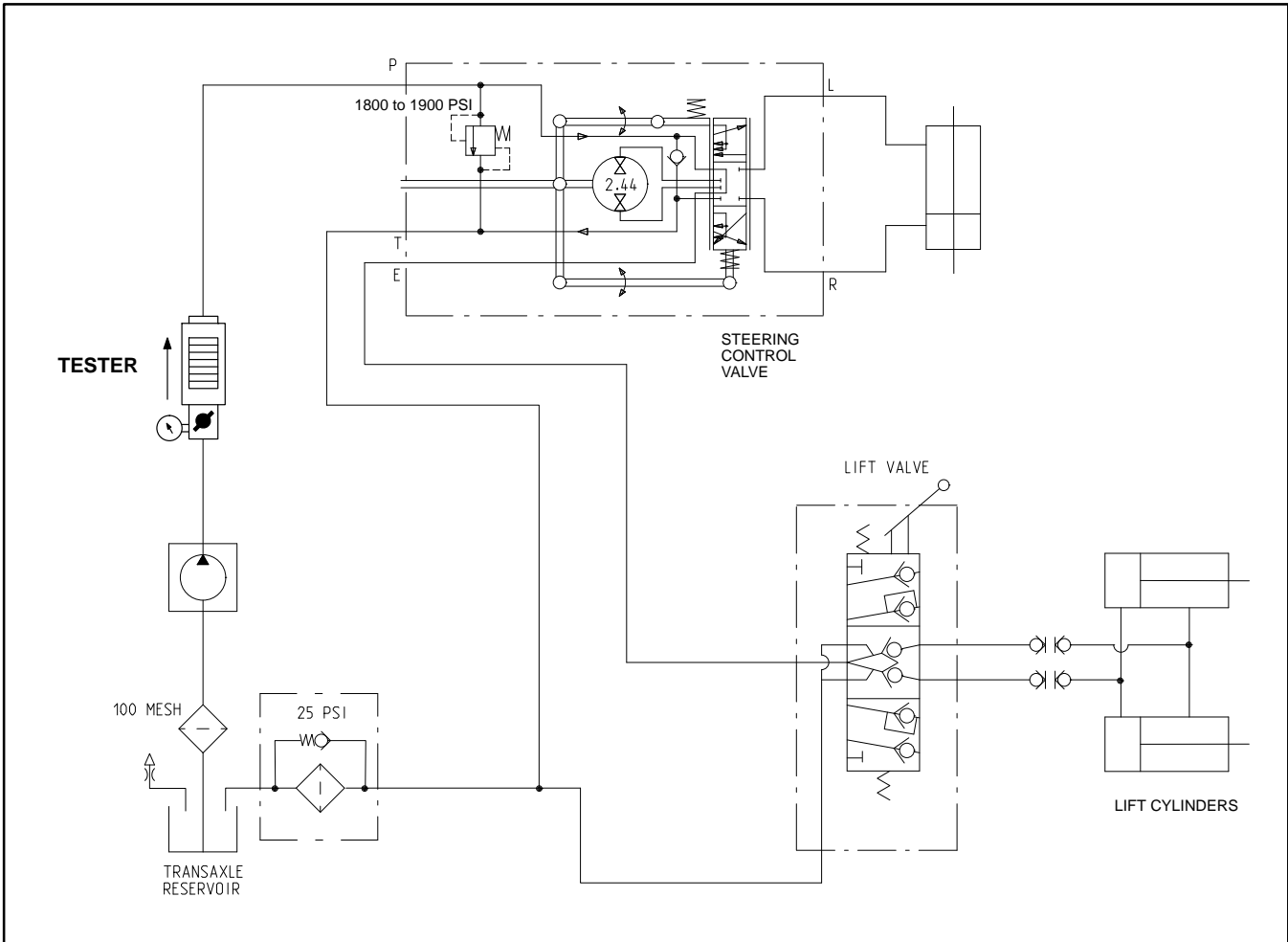

Figure 16

**NOTE:** This test procedure is for the primary hydraulic system gear pump used on Workman HDX and HDX-D vehicles. If vehicle is equipped with the High Flow Hydraulics Kit, use this test for the primary hydraulic system pump section and refer to the High Flow Hydraulic System Gear Pump Flow and Relief Pressure Test for testing of the high flow hydraulic system pump section.

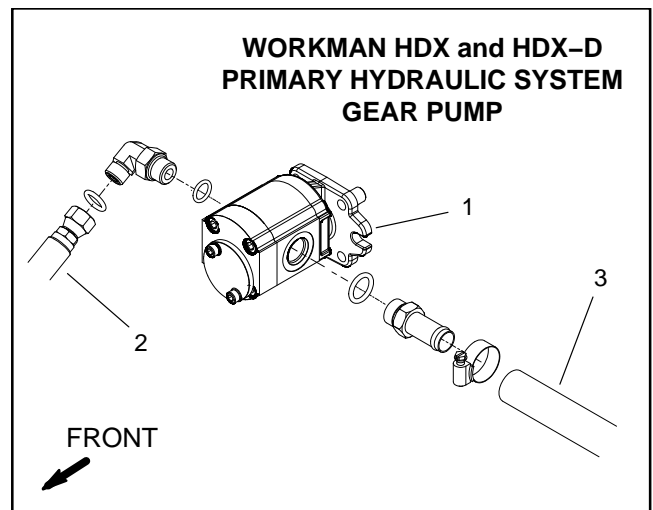

Figure 17

- 1. Gear pump
- 2. Pressure hose
- 3. Suction hose



## Procedure for Primary Hydraulic System Gear Pump Flow (Workman HDX and HDX-D)

The primary hydraulic system gear pump is designed to satisfy both steering cylinder and lift cylinder needs simultaneously (at full speed throttle). If unit steering is sluggish or otherwise performs poorly, see Steering Control Valve and Steering Cylinder Test in this chapter.

If lift operation is unsatisfactory, check lift control valve and/or lift cylinders. Additional information on these components is available in this chapter.

If both steering and lift operations perform poorly, perform the primary hydraulic system gear pump flow test and relief valve pressure test. This test compares fluid flow at No Load with fluid flow Under Load. A drop in flow under load of more than **15%** indicates the gears and wear plates in the pump have worn. Continued operation with a worn pump can generate excessive heat and cause damage to the seals and other components in the hydraulic system.

### Special Equipment Required:

- Flow Meter with Pressure Gauge that has at least a 5 GPM (19 LPM) capacity.

1. Park vehicle on a level surface, raise and support bed (if installed), shut engine off and engage the parking brake. After turning engine off, operate all hydraulic controls to relieve hydraulic system pressure.

**CAUTION**

**Prevent personal injury and/or damage to equipment. Read all WARNINGS, CAUTIONS and Precautions for Hydraulic Testing at the beginning of this section.**

**IMPORTANT: Make sure that the oil flow indicator arrow on the flow meter is showing that the oil will flow from the pump, through the tester and into the hydraulic hose.**

2. With the engine off, clean hose fitting and disconnect the pressure hose from the gear pump (Fig. 17). Install tester with pressure gauges and flow meter in series between the gear pump and the disconnected hose. **Make sure the tester flow control valve is fully open.**

3. Make sure the hydraulic reservoir (transaxle) is full after connecting the tester.

**CAUTION**

**The engine must be running to perform hydraulic tests. To guard against possible personal injury, engage parking brake and keep clothing, hands, feet, face and other parts of the body away from fan and other moving parts.**

4. Make sure hydraulic oil is at normal operating temperature by operating the vehicle for approximately ten (10) minutes. Check for hydraulic leakage and correct before proceeding with test.

5. Fully depress and hold accelerator pedal. Check that engine or pump speed is **3600 RPM**. Verify engine or pump speed with a phototac.

6. Verify pump flow at No Load as follows:

A. Record tester pressure and flow readings at no load. Unrestricted pump output should be approximately **4.8 GPM (18.2 LPM)**.

7. Verify pump flow Under Load as follows:

**CAUTION**

**Do not close tester valve fully when performing this test. In this test, the hydraulic tester is positioned before the circuit relief valve. Pump damage can occur if the fluid flow is fully restricted by fully closing the tester flow control valve.**

A. Watch pressure gauge carefully while slowly closing the flow control valve until **1500 PSI (103 Bar)** is obtained on gauge.

B. Record tester pressure and flow readings under load.

8. Release accelerator pedal and shut off engine.

9. The under load test flow reading (step 7.B) should not drop **more than 15%** when compared to the no load test flow reading (step 6.A). A difference in flow of more than 15%, or the inability to achieve specified pressure may indicate:

- A. A restriction in the pump intake line
- B. The primary hydraulic system gear pump is worn and should be repaired or replaced

10. Disconnect tester and reconnect hose to pump.

11. Make sure the hydraulic reservoir (transaxle) is full before returning the vehicle to service.

**NOTE:** If necessary, circuit relief valve pressure test can be conducted with tester in the same location as for this test (see Primary Hydraulic System Relief Valve Pressure Test in this chapter).

This page is intentionally blank.

# Primary Hydraulic System Gear Pump Flow Test (Workman HD)

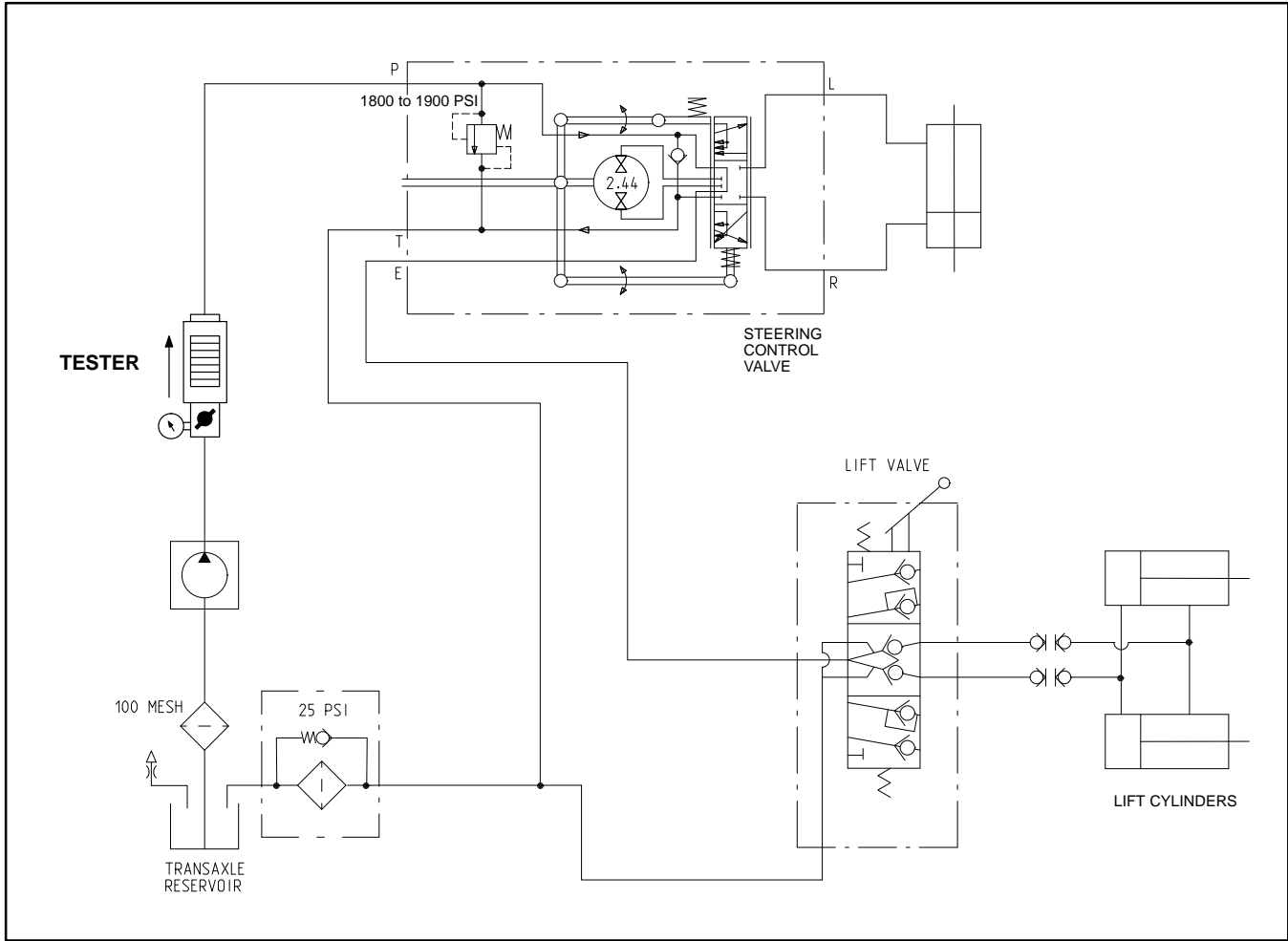

Figure 18

**NOTE:** This test procedure is for the belt driven primary hydraulic system gear pump used on Workman HD vehicles.

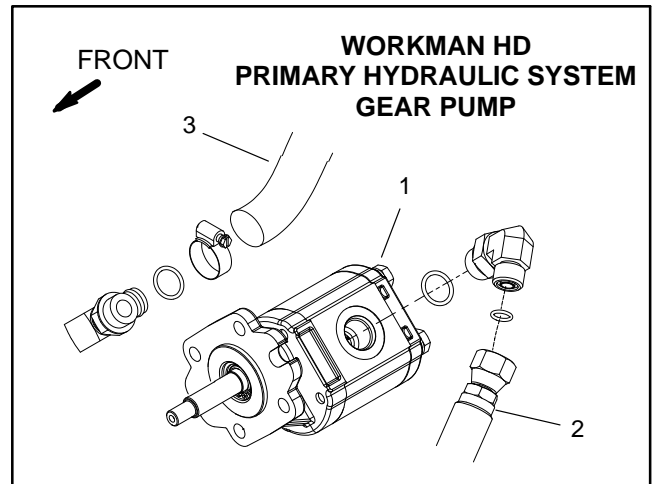

Figure 19

- 1. Gear pump
- 2. Pressure hose
- 3. Suction hose

## Procedure for Primary Hydraulic System Gear Pump Flow Test (Workman HD)

The primary hydraulic system gear pump is designed to satisfy both steering cylinder and lift cylinder needs simultaneously (at full speed throttle). If unit steering is sluggish or otherwise performs poorly, see Steering Control Valve and Steering Cylinder Test in this chapter.

If lift operation is unsatisfactory, check lift control valve and/or lift cylinders. Additional information on these components is available in this chapter.

If both steering and lift operations perform poorly, perform the primary hydraulic system gear pump flow test and relief valve pressure test. This test compares fluid flow at No Load with fluid flow Under Load. A drop in flow under load of more than **15%** indicates the gears and wear plates in the pump have worn. Continued operation with a worn pump can generate excessive heat and cause damage to the seals and other components in the hydraulic system.

### Special Equipment Required:

- Flow Meter with Pressure Gauge that has at least a 5 GPM (19 LPM) capacity.

1. Park vehicle on a level surface, raise and support bed (if installed), shut engine off and engage the parking brake. After turning engine off, operate all hydraulic controls to relieve hydraulic system pressure.
2. Make sure that gear pump drive belt is adjusted properly (see Operator's Manual).

**CAUTION**

**Prevent personal injury and/or damage to equipment. Read all WARNINGS, CAUTIONS and Precautions for Hydraulic Testing at the beginning of this section.**

**IMPORTANT: Make sure that the oil flow indicator arrow on the flow meter is showing that the oil will flow from the pump, through the tester and into the hydraulic hose.**

3. With the engine off, clean hose fitting and disconnect the pressure hose from the gear pump (Fig. 19). Install tester with pressure gauges and flow meter in series between the gear pump and the disconnected hose. **Make sure the tester flow control valve is open.**

4. Make sure the hydraulic reservoir (transaxle) is full after connecting the tester.

**CAUTION**

**The engine must be running to perform hydraulic tests. To guard against possible personal injury, engage parking brake and keep clothing, hands, feet, face and other parts of the body away from moving vehicle parts while testing.**

5. Make sure hydraulic oil is at normal operating temperature by operating the vehicle for approximately ten (10) minutes. Check for hydraulic leakage and correct before proceeding with test.

6. Fully depress and hold accelerator pedal. Check that engine speed is **3600 RPM** and also check that pump speed is approximately **2270 RPM**. Verify engine and pump speed with a phototac.

7. Verify pump flow at No Load as follows:

- A. Record tester pressure and flow readings at no load. Unrestricted pump output should be approximately **3.5 GPM (13.2 LPM)**.

8. Verify pump flow Under Load as follows:

**CAUTION**

**Do not close tester valve fully when performing this test. In this test, the hydraulic tester is positioned before the circuit relief valve. Pump damage can occur if the fluid flow is fully restricted by fully closing the tester flow control valve.**

- A. Watch pressure gauge carefully while slowly closing the flow control valve until **1500 PSI (103 Bar)** is obtained on gauge.

- B. Record tester pressure and flow readings under load.

9. Release accelerator pedal and shut off engine.

10. The under load test flow reading (step 7.B) should not drop **more than 15%** when compared to the no load test flow reading (step 6.A). A difference in flow of more than 15%, or the inability to achieve specified pressure may indicate:

- A. A restriction in the pump intake line
- B. A slipping pump drive belt
- C. The primary hydraulic system gear pump is worn and should be repaired or replaced

D. If pump speed of 2270 RPM cannot be maintained during test, consider that engine performance problems exist.

11. Disconnect tester and reconnect hose to pump.

12. Make sure the hydraulic reservoir (transaxle) is full before returning the vehicle to service.

**NOTE:** If necessary, circuit relief valve pressure test can be conducted with tester in the same location as for this test (see Primary Hydraulic System Relief Valve Pressure Test in this chapter).

This page is intentionally blank.

# Primary Hydraulic System Relief Valve Pressure Test

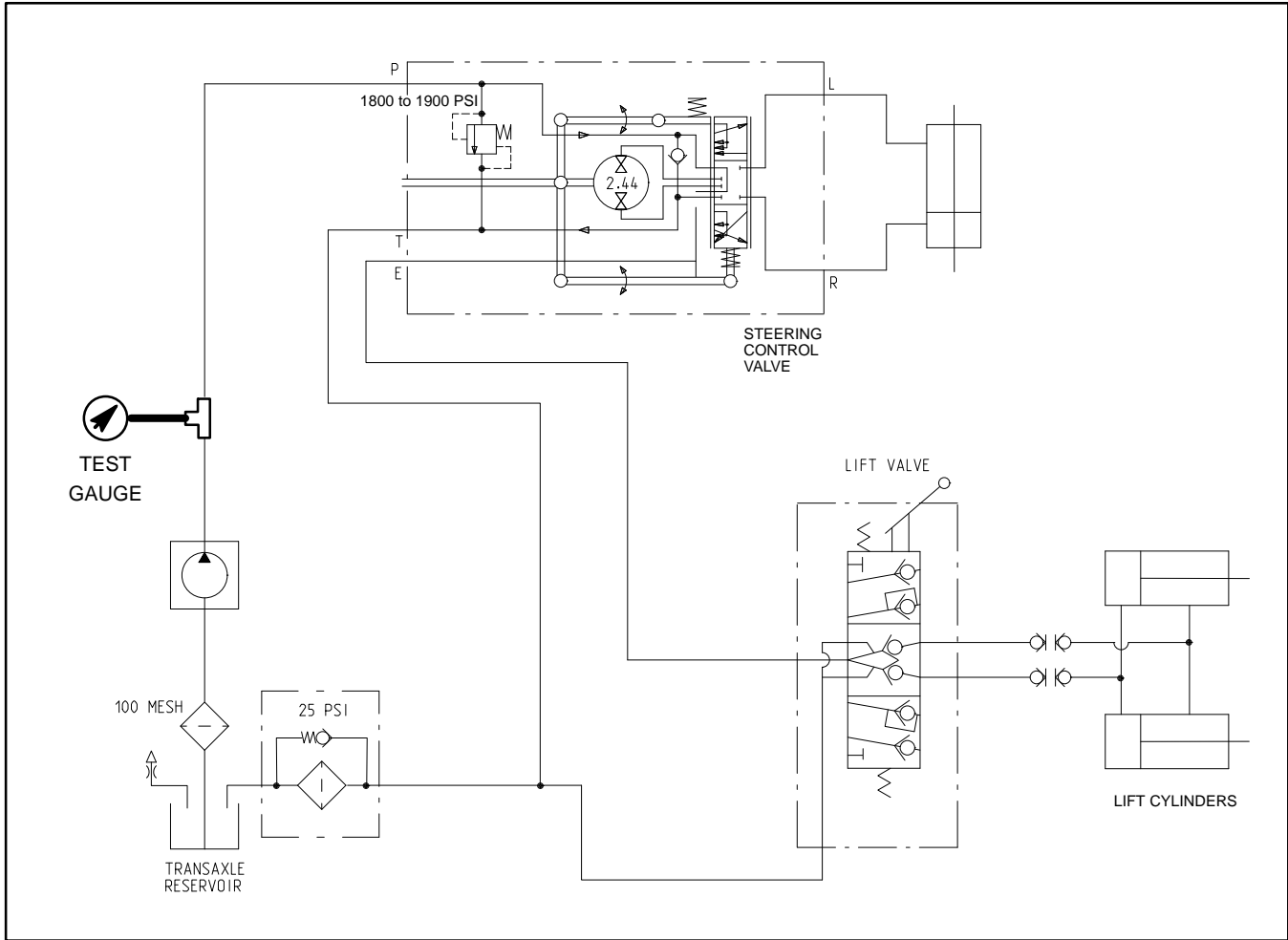

Figure 20

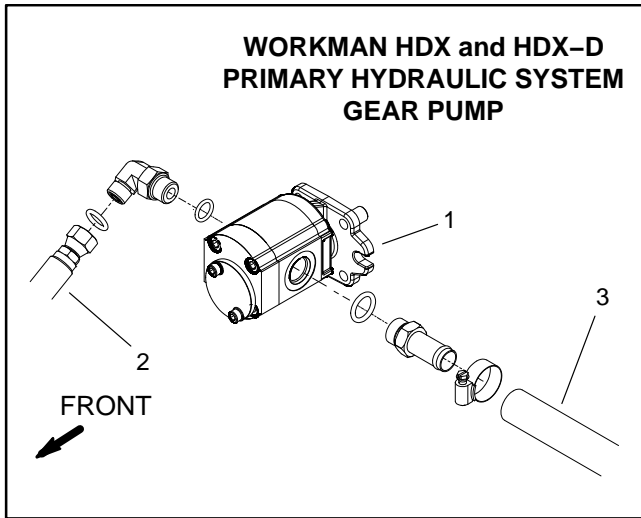

Figure 21

- 1. Gear pump
- 2. Pressure hose
- 3. Suction hose

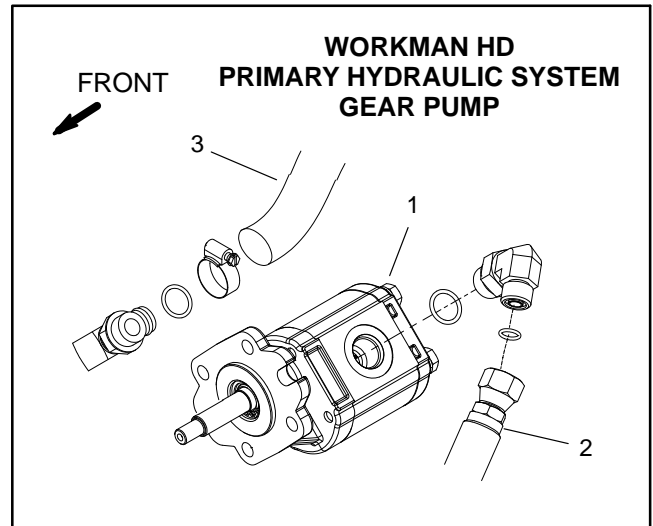

Figure 22

- 1. Gear pump
- 2. Pressure hose
- 3. Suction hose



### Primary Hydraulic System Relief Valve Pressure Test:

The relief valve for the steering and lift circuits is integrated into the steering control valve. If both steering and lift operations perform poorly, perform the relief valve pressure test and primary hydraulic system gear pump flow test (see Primary Hydraulic System Gear Pump Flow Test in this chapter).

**NOTE:** If available, using a flow meter with pressure gauge that has at least a 5 GPM (16 LPM) capacity instead of a pressure gauge (as described in this test) will allow performing the relief valve test and the pump (P2) flow test with the same test configuration (see Primary Hydraulic System Gear Pump Flow Test in this chapter).

1. Park machine on a level surface with the cutting units lowered and PTO switch off. Make sure engine is off and the parking brake is engaged.
2. Read Precautions for Hydraulic Testing in this chapter.
3. Disconnect hose connection on primary hydraulic system gear pump leading to the steering control valve (Fig. 21 or 22).
4. Install T–connector with test gauge between the gear pump and the disconnected hose.
5. Make sure the hydraulic reservoir (transaxle) is full after connecting the T–connector with test gauge.
6. Make sure steering wheel is positioned so the front wheel points directly ahead.

7. Start engine and depress accelerator pedal so engine is running at high idle (**3600 RPM**).

8. Make sure hydraulic fluid is at normal operating temperature by operating the machine for approximately 10 minutes.

9. Watch pressure gauge carefully while turning the steering wheel completely in one direction and holding.



### CAUTION

**Do not allow pressure to exceed 2000 PSI. Hold steering wheel at full lock only long enough to get a system pressure reading. Holding the steering wheel against the stop for an extended period may damage the steering control valve.**

10. System pressure should reach **1800 to 1900 PSI (124 to 131 Bar)** as the relief valve opens.

11. Return steering wheel to the center position, release accelerator pedal and shut off engine.

12. If relief pressure is incorrect, inspect for a worn or stuck relief valve in steering control valve (see Steering Control Valve Service in this chapter).

13. Disconnect T–connector with test gauge and reconnect hydraulic hose to gear pump.

14. Make sure the hydraulic reservoir (transaxle) is full before returning the vehicle to service.

# Steering Control Valve and Steering Cylinder Test

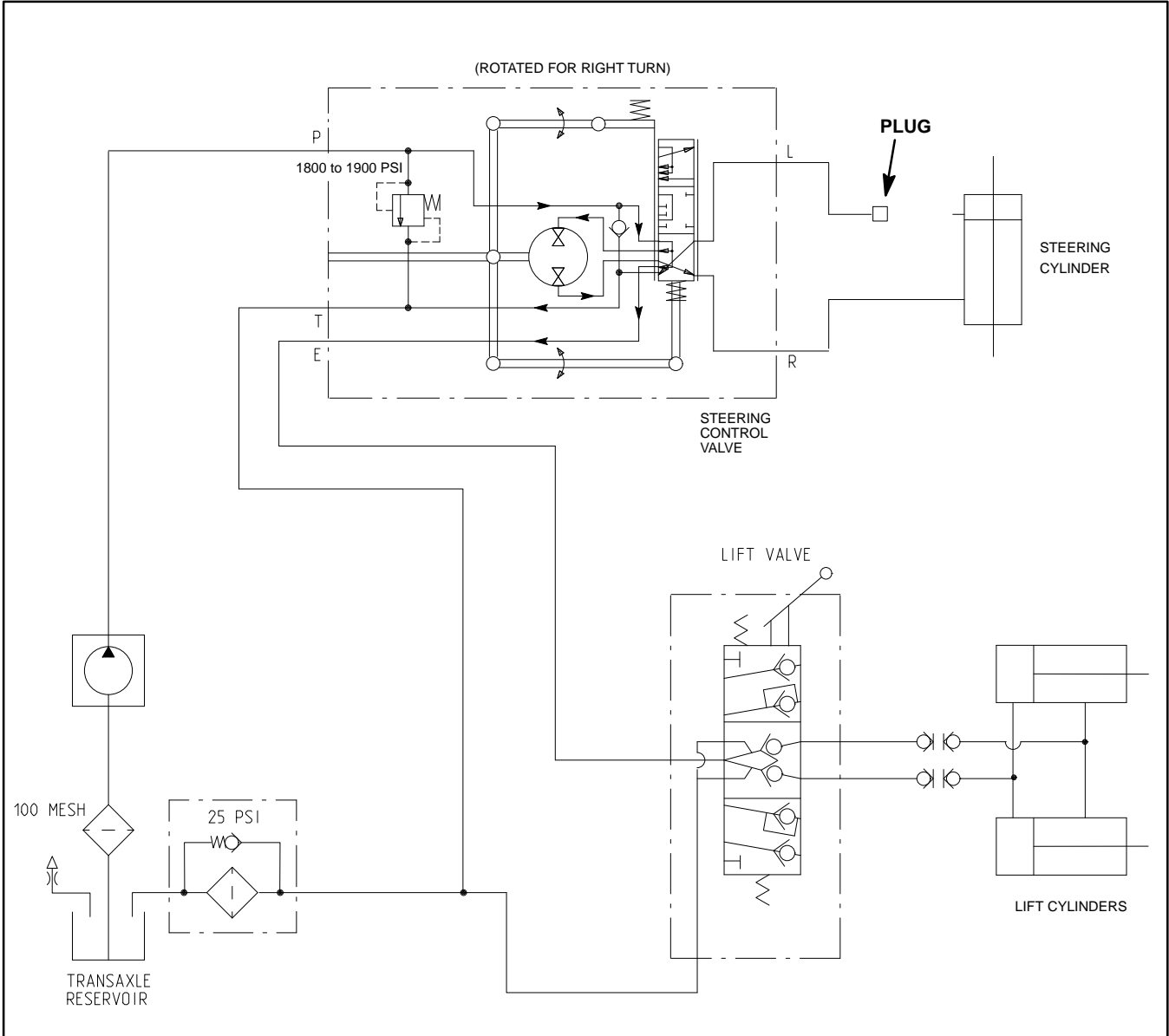

Figure 23

## Procedure for Steering Control Valve and Steering Cylinder Test

This steering test procedure will be affected by incorrect tire pressure, binding of the hydraulic steering cylinder, excessive weight on the vehicle and/or binding of the steering assembly (e.g. wheel spindles, tie rods). Make sure that these items are checked before proceeding with any hydraulic testing procedure.

1. Make sure hydraulic oil is at normal operating temperature by operating the vehicle for approximately ten (10) minutes.
2. Drive vehicle slowly in a figure eight on a flat level surface.
  - A. There should be no shaking or vibration in the steering wheel or front wheels.
  - B. Steering wheel movements should be followed **immediately** by a corresponding front wheel movement **without** the steering wheel continuing to turn.
3. Stop vehicle with the engine running. Turn steering wheel with small quick movements in both directions. Let go of the steering wheel after each movement. The steering wheel or front wheels should **not** continue to turn.
4. If either of these performance tests indicate a steering problem, determine if the steering cylinder is faulty using the following procedure.
  - A. Park vehicle on a level surface.
  - B. With the engine running, turn the steering wheel to the right (clockwise) until the steering cylinder rod is fully extended.
  - C. Turn engine off and engage the parking brake.
  - D. Read Precautions for Hydraulic Testing.
  - E. Clean and remove hydraulic hose from the fitting on the rod end of the steering cylinder. Plug the end of the disconnected hose (Fig. 23).



## WARNING

**Keep body and hands away from disconnected hoses and fittings that might eject hydraulic fluid under high pressure. Use paper or cardboard, not hands, to search for leaks. Hydraulic fluid escaping under pressure can have sufficient force to penetrate the skin and cause serious injury. If fluid is injected into the skin, it must be surgically removed within a few hours by a doctor familiar with this type of injury. Gangrene may result from such an injury.**

**IMPORTANT: Do not turn steering wheel to the left (counterclockwise) as system damage may occur.**

- F. With the engine off, continue turning the steering wheel to the right (clockwise) with the steering cylinder fully extended. Observe the open fitting on the steering cylinder as the wheel is turned. If oil comes out of the fitting while turning the steering wheel to the right, the steering cylinder has internal leakage and must be repaired or replaced.
  - G. Remove plug from the disconnected hydraulic hose. Reconnect hose to the steering cylinder.
5. If steering problem exists and the steering cylinder, primary hydraulic system gear pump flow and system relief pressure tested acceptably, steering control valve requires service (see Steering Control Valve and Steering Control Valve Service in this chapter).

# Lift Cylinder Internal Leakage Test

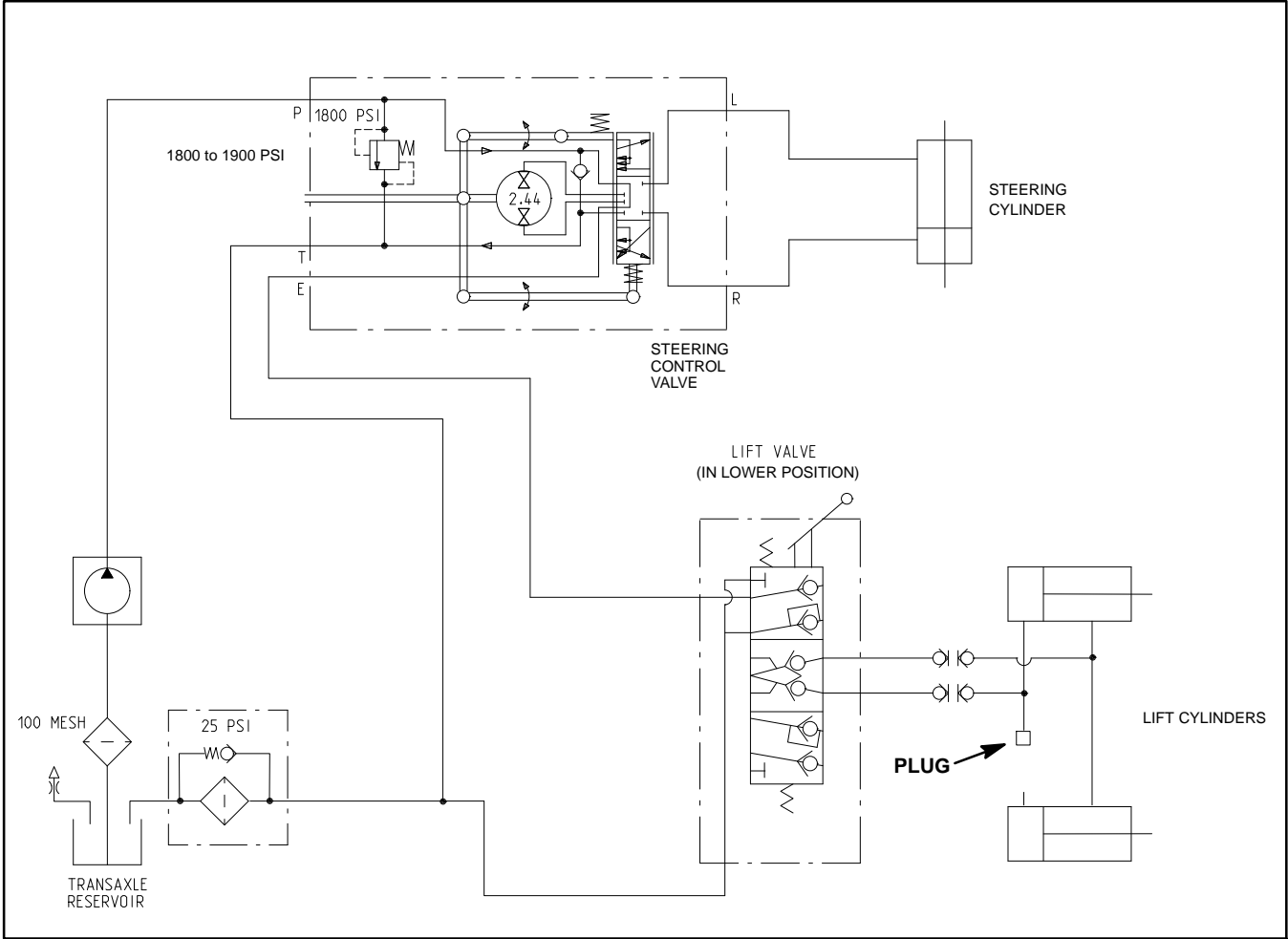

Figure 24

## Procedure for Lift Cylinder Internal Leakage Test

1. Shut off engine and engage parking brake.

	<b>CAUTION</b>
<b>Prevent personal injury and/or damage to equipment. Read all WARNINGS, CAUTIONS and Precautions for Hydraulic Testing at the beginning of this section.</b>	

2. Remove all pressure from cylinder by fully retracting it (i.e. put hydraulic lift lever in LOWER position).
3. Disconnect hydraulic hose from base end of cylinder and install a steel plug with O-ring seal in the hose (Fig. 25). Clean any remaining oil from cylinder port.
4. Start engine and apply pressure to rod end of cylinder (move hydraulic lift lever to LOWER position).
5. If any oil comes out of open cylinder port, cylinder has an internal leak. Repair or replace cylinder.
6. Reconnect hose after testing is complete.

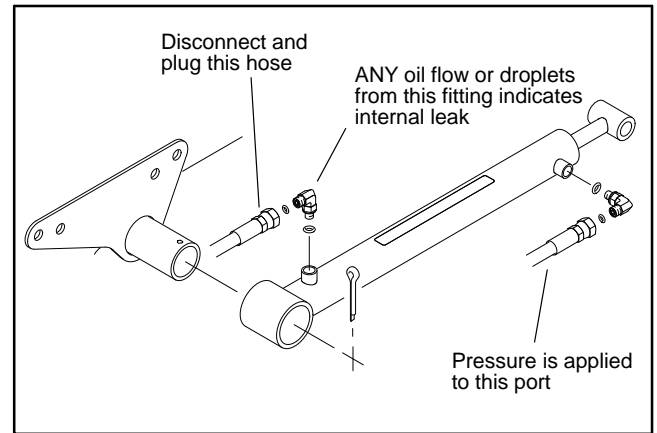

Figure 25

# High Flow Hydraulic System Gear Pump Flow and Relief Pressure Tests

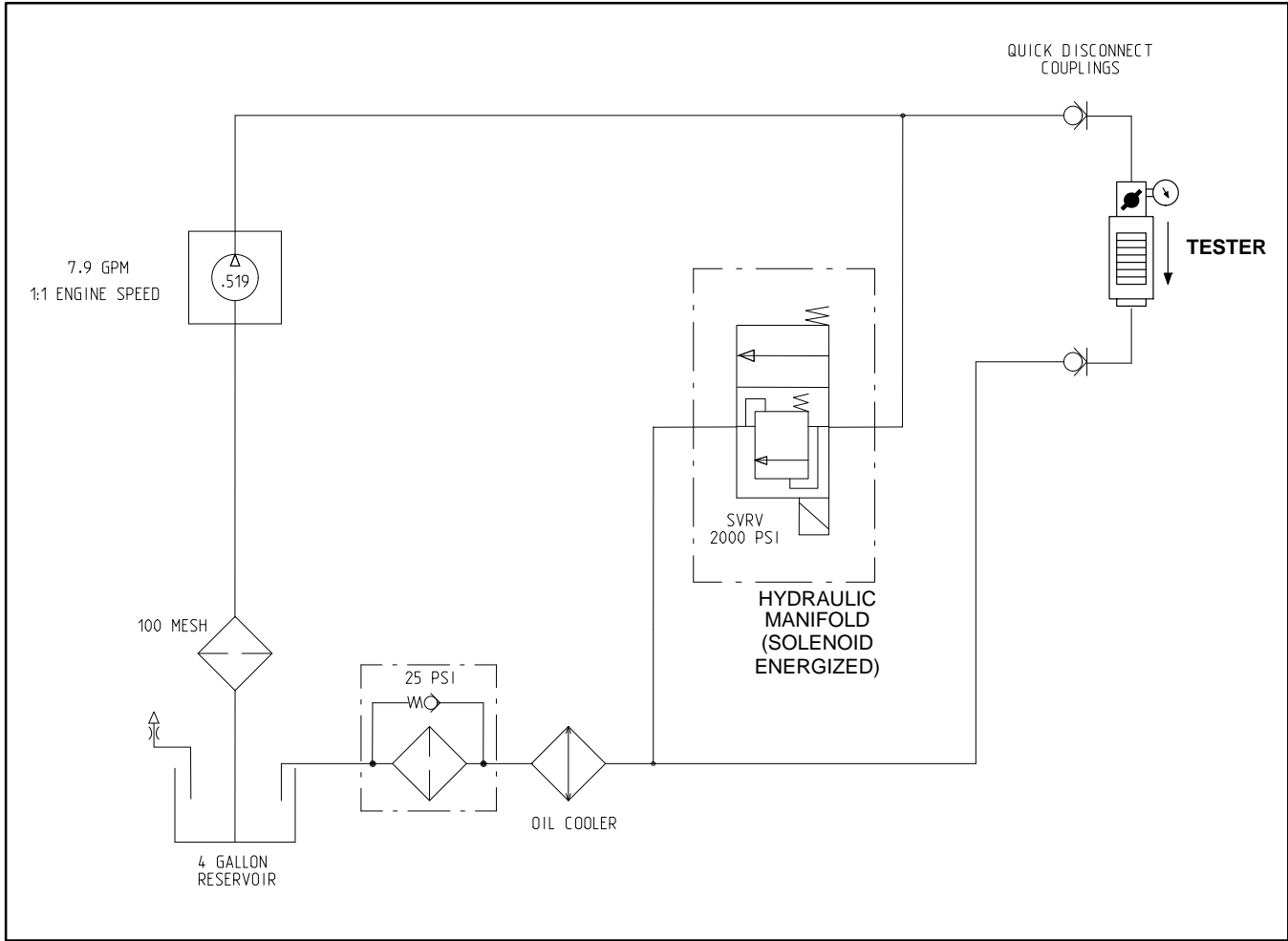

Figure 26

**NOTE:** This test procedure is for the high flow hydraulic system gear pump and high flow hydraulic system relief valve on Workman HDX and HDX-D vehicles that are equipped with the High Flow Hydraulics Kit. For testing the primary hydraulic system gear pump or primary hydraulic system relief valve on vehicles with this kit, refer to the Primary Hydraulic System Gear Pump Flow Test (Workman HDX and HDX-D) or Primary Hydraulic System Relief Pressure tests.

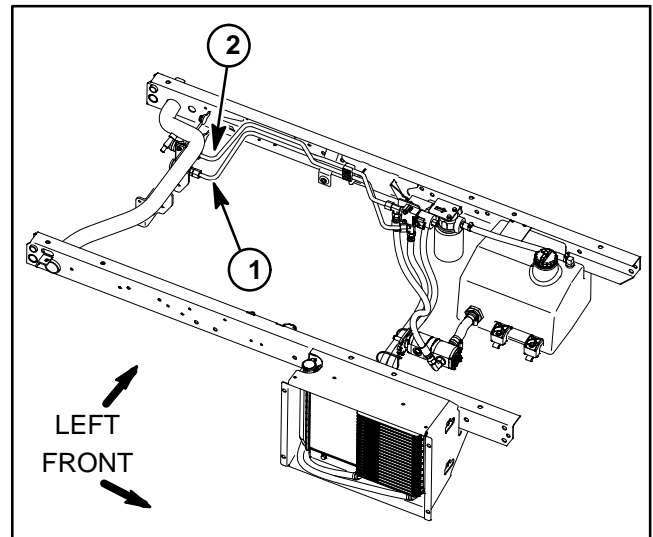

Figure 27

- 1. Pressure coupler
- 2. Return coupler

## Procedure for High Flow Hydraulics System Gear Pump Flow and Relief Pressure Tests

If both steering and lift operations perform poorly, perform the primary hydraulic system gear pump flow test and relief valve pressure test. This test compares fluid flow at No Load with fluid flow Under Load. A drop in flow under load of more than **15%** indicates the gears and wear plates in the pump have worn. Continued operation with a worn pump can generate excessive heat and cause damage to the seals and other components in the hydraulic system.

### Special Equipment Required:

- Flow Meter with Pressure Gauge that has at least a 10 GPM (38 LPM) capacity.

1. Make sure hydraulic oil is at normal operating temperature by operating the vehicle for approximately ten (10) minutes.
2. Park vehicle on a level surface, raise and support bed (if installed), shut engine off and apply the parking brake. After turning engine off, operate all hydraulic controls to relieve hydraulic system pressure.



**IMPORTANT: Make sure that the oil flow indicator arrow on the flow meter is showing that the oil will flow from the pressure coupler, through the tester and into the return (tank) coupler (Fig. 27).**

3. With the engine off, install tester with pressure gauges and flow meter in series between the quick disconnect couplings at the rear of the vehicle. **Make sure the tester flow control valve is open.**
4. Make sure the High Flow Kit reservoir is full.

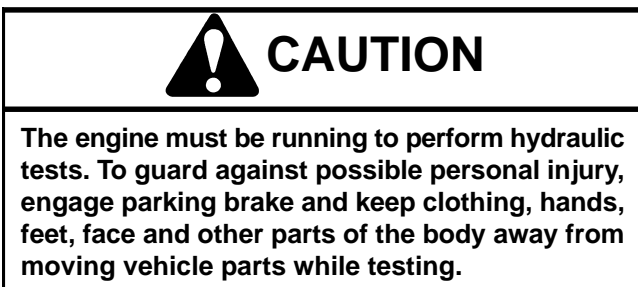

5. After installing tester, start engine and run at idle speed. Turn High Flow Kit switch ON and check for hydraulic leakage from connections. Correct before proceeding with test.

6. Depress accelerator pedal fully so engine or pump speed is **3600 RPM**. Verify engine or pump speed with a phototac.

A. Record tester pressure and flow readings at no load. Unrestricted pump output should be approximately **7.7 GPM (29 LPM)**.

7. Verify pump flow Under Load as follows:

A. Watch pressure gauge carefully while slowly closing the flow control valve until **1500 PSI (103 Bar)** is obtained on gauge.

B. Record tester pressure and flow readings under load.

8. Open tester flow control valve, release accelerator pedal to allow engine to return to low idle, turn High Flow Kit switch OFF and stop engine.

9. The under load test flow reading (step 7.B) should not drop **more than 15%** when compared to the no load test flow reading (step 6.A). A difference in flow of more than 15%, or the inability to achieve specified pressure may indicate:

A. Worn or stuck relief valve (SVRV)

B. A restriction in the pump intake line

C. The high flow hydraulic system gear pump is worn and should be repaired or replaced

10. To test high flow hydraulic system relief pressure:

A. Make sure flow control valve on tester is fully open.

B. Start engine and depress accelerator pedal so engine or pump is operating at high idle (**3600 RPM**). Turn High Flow Kit switch ON.

**IMPORTANT: Close flow control valve on tester only enough to get a system relief pressure reading.**

C. Watch pressure gauge carefully while slowly closing the tester flow control valve until the relief valve opens.

D. System pressure should be approximately **2000 PSI (138 bar)** as the relief valve lifts.

E. Open tester flow control valve, release accelerator pedal to allow engine to return to low idle, turn High Flow Kit switch OFF and stop engine. Record test results.

11. If relief pressure is incorrect, inspect for a worn, stuck or damaged relief valve (SVRV) in control manifold (see Hydraulic Manifold (High Flow Hydraulics Kit) in the Service and Repairs section of this chapter).

12. Remove tester from vehicle.



# Service and Repairs

---

## General Precautions for Removing and Installing Hydraulic System Components

### Before Repair or Replacement of Components

1. Before removing any parts from the hydraulic system, park vehicle on a level surface, engage parking brake and stop engine. Remove key from the ignition switch.
2. Clean vehicle before disconnecting, removing or disassembling any hydraulic components. Make sure hydraulic components, hoses connections and fittings are cleaned thoroughly. Always keep in mind the need for cleanliness when working on hydraulic equipment.

	<b>CAUTION</b>
<p><b>Before performing any service or repair on hydraulic system components, relieve system pressure to avoid injury from pressurized hydraulic oil. Stop the engine, remove key from the ignition switch, rotate the steering wheel in both directions, lower or support the bed and operate other hydraulic accessories.</b></p>	

3. Put caps or plugs on any hydraulic lines, hydraulic fittings and components left open or exposed to prevent hydraulic system contamination.
4. Put labels on disconnected hydraulic lines and hoses for proper installation after repairs are completed.
5. Note the position of hydraulic fittings (especially elbow fittings) on hydraulic components before removal. Mark parts if necessary to make sure they will be aligned properly when reinstalling hydraulic hoses and tubes.

### After Repair or Replacement of Components

1. Check oil level in the transaxle and add correct oil if necessary. Drain and refill transaxle and change oil filter if component failure was severe or system is contaminated.
2. Lubricate O-rings and seals with clean hydraulic oil before installing hydraulic components.
3. Make sure caps or plugs are removed from the hydraulic tubes, hydraulic fittings and components before reconnecting.
4. Use proper tightening methods when installing hydraulic hoses and fittings (see Hydraulic Hose and Tube Installation and Hydraulic Fitting Installation in the General Information section of this chapter).
5. After disconnecting or replacing any hydraulic components, operate vehicle functions slowly until air is out of system.
6. Check for hydraulic oil leaks. Shut off engine and correct leaks if necessary. Check oil level in transaxle and add correct oil if necessary.

---

## Check Hydraulic Lines and Hoses

	<b>WARNING</b>
<p><b>Keep body and hands away from pin hole leaks or nozzles that eject hydraulic fluid under high pressure. Use paper or cardboard, not hands, to search for leaks. Hydraulic fluid escaping under pressure can have sufficient force to penetrate the skin and cause serious injury. If fluid is injected into the skin, it must be surgically removed within a few hours by a doctor familiar with this type of injury. Gangrene may result from such an injury.</b></p>	

Check hydraulic lines and hoses daily for leaks, kinked lines, loose mounting supports, wear, loose fittings or general deterioration. Make all necessary repairs before vehicle operation.

# Primary Hydraulic System Gear Pump (Workman HDX and HDX-D)

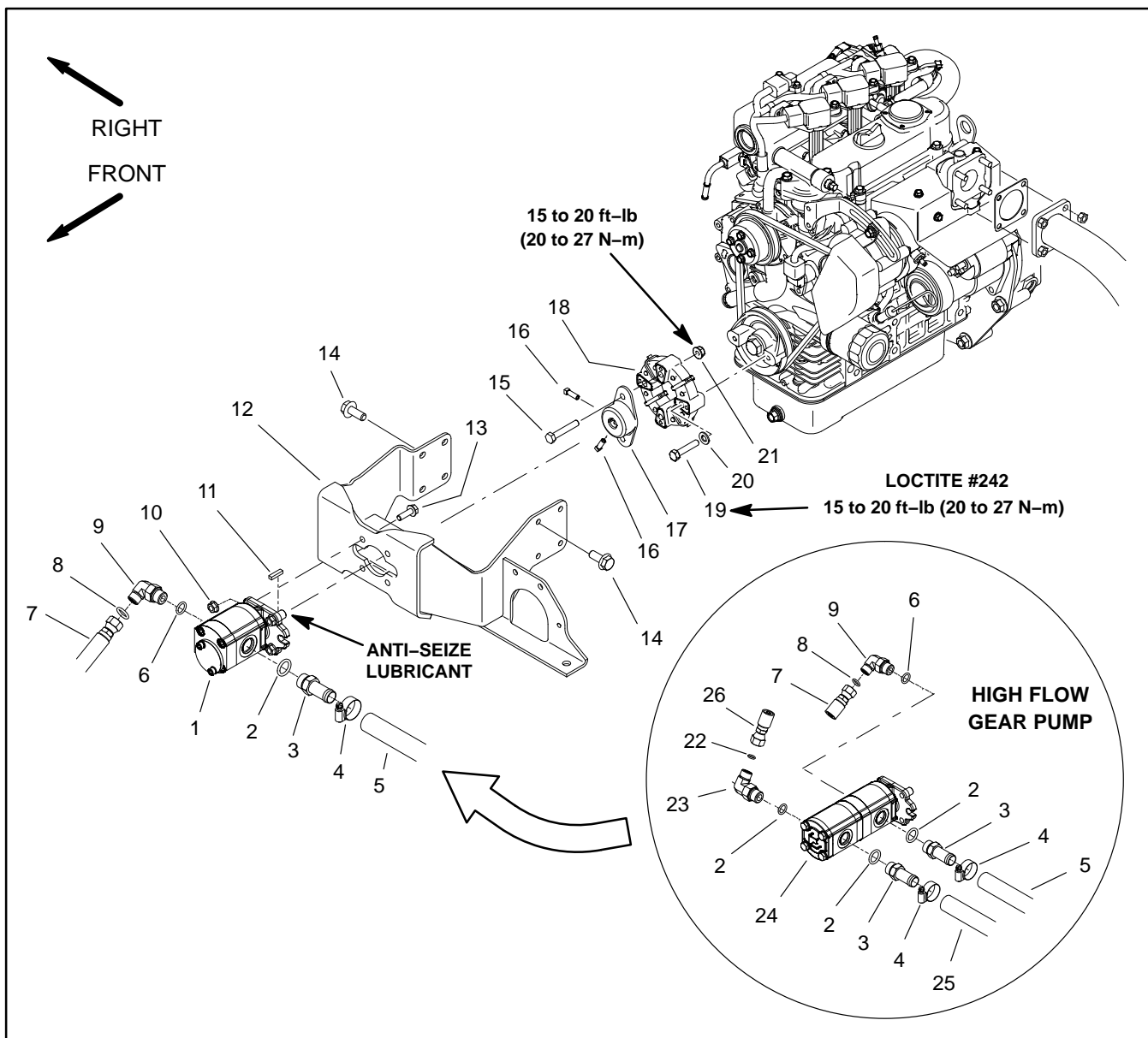

Figure 28

- |                                  |                           |                                   |
|----------------------------------|---------------------------|-----------------------------------|
| 1. Gear pump                     | 10. Flange nut (4)        | 19. Hex head screw (2)            |
| 2. O-ring                        | 11. Square key            | 20. Flat washer (2)               |
| 3. Hydraulic fitting             | 12. Pump/engine mount     | 21. Hex flange nut (2)            |
| 4. Hose clamp                    | 13. Flange head screw (4) | 22. O-ring                        |
| 5. Suction hose (from transaxle) | 14. Flange head screw (8) | 23. 90 hydraulic fitting          |
| 6. O-ring                        | 15. Hex head screw (2)    | 24. High flow gear pump           |
| 7. Hose (to lift valve)          | 16. Square head screw (2) | 25. Suction hose (from reservoir) |
| 8. O-ring                        | 17. Pump hub              | 26. Hose (to high flow manifold)  |
| 9. Hydraulic fitting             | 18. Coupling              |                                   |

**NOTE:** The primary hydraulic system gear pump used on Workman HDX and HDX-D vehicles is a single gear pump. If the High Flow Hydraulics Kit is installed, a second pump section is added to the primary system gear pump. Both gear pump assemblies are shown (Fig. 28).

## Removal (Fig. 28)

1. Park vehicle on a level surface, raise and support bed (if installed), shut engine off and engage parking brake. Remove key from the ignition switch.
2. Read the General Precautions for Removing and Installing Hydraulic System Components at the beginning of this section.

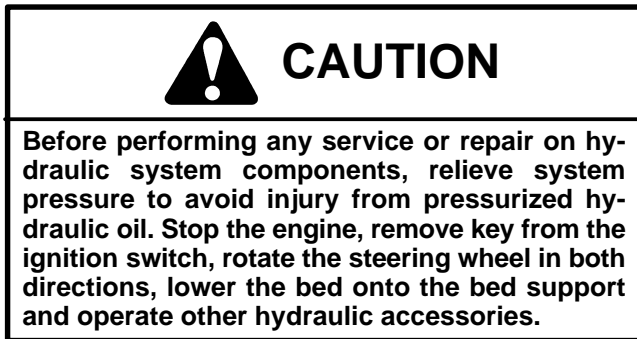

**NOTE:** If vehicle is equipped with High Flow Hydraulics Kit, label hydraulic hoses for assembly purposes.

3. Thoroughly clean junction of hydraulic hoses and gear pump fittings. Disconnect hydraulic hoses from gear pump. Install caps or plugs in hoses and pump fittings to prevent contamination and leakage of hydraulic oil.
4. Loosen two (2) set screws on the pump hub to allow pump hub removal from the gear pump shaft.
5. Support gear pump to prevent it from falling during removal.
6. Remove four (4) flange nuts and flange head screws that secure pump to mount.
7. Slide gear pump shaft out of pump hub and remove gear pump from vehicle. Locate and retrieve square key from the pump shaft.
8. If hydraulic fittings are to be removed from gear pump, mark fitting orientation to allow correct assembly. Remove fittings from pump and discard O-rings.

## Installation (Fig. 28)

1. If fittings were removed from gear pump, lubricate and place new O-rings onto fittings. Install fittings into pump openings using marks made during the removal process to properly orientate fittings. Tighten fittings (see Hydraulic Fitting Installation in this chapter).
  2. Install square key to the pump shaft. Apply antiseize lubricant to gear pump shaft.
  3. Align pump shaft to pump hub. Slide pump toward the rear of machine until pump flange holes align with holes in mount. Take care to not damage the pump coupling.
  4. Install four (4) flange head screws and flange nuts to secure pump to mount. Do not fully tighten fasteners.
  5. Tighten both screws (item 23) on the pump hub to secure hub to the pump shaft.
  6. Allow coupler assembly to locate pump making sure that no deflection of coupler components exists. Fully tighten fasteners to secure pump to mount.
  7. Remove plugs from hydraulic hoses and pump fittings. Connect hydraulic hoses to gear pump (see Hydraulic Hose and Tube Installation in the General Information section of this chapter).
- IMPORTANT:** The hydraulic system used on vehicles with the High Flow Hydraulics Kit use two (2) separate hydraulic reservoirs and hydraulic fluid type. Make sure to use correct oil when adding hydraulic oil to the hydraulic system.
8. Check oil level in the reservoir(s) and add correct oil if necessary.
  9. Start the engine and operate at idle speed until air is out of hydraulic system.
  10. Stop the engine and recheck oil level in reservoir(s). Add correct oil if necessary.

## Primary Hydraulic System Gear Pump (Workman HD)

### Removal (Fig. 29)

1. Park vehicle on a level surface, raise and support bed (if installed), shut engine off and engage the parking brake. Remove key from the ignition switch.
2. Loosen pump drive belt and remove belt from pump pulley.
3. Read the General Precautions for Removing and Installing Hydraulic System Components at the beginning of this chapter section.



### CAUTION

Before performing any service or repair on hydraulic system components, relieve system pressure to avoid injury from pressurized hydraulic oil. Stop the engine, remove key from the ignition switch, rotate the steering wheel in both directions, lower the bed onto the bed support and operate other hydraulic accessories.

4. Disconnect hydraulic hoses from gear pump. Install caps or plugs in hoses and pump fittings to prevent contamination and leakage of hydraulic oil.
5. Remove gear pump from mount.
6. If hydraulic fittings are to be removed from gear pump, mark fitting orientation to allow correct assembly. Remove fittings from pump and discard O-rings.

### Installation (Fig. 29)

1. If fittings were removed from gear pump, lubricate and place new O-rings onto fittings. Install fittings into pump openings using marks made during the removal process to properly orientate fittings. Tighten fittings (see Hydraulic Fitting Installation in the General Information section of this chapter).
2. Install gear pump to mount (Fig. 29) using the following instructions:
  - A. Apply antiseize lubricant to gear pump shaft before installing pulley.
  - B. Install pump suction hose to fitting on pump, then fill pump through pressure port of pump, with clean Dexron III ATF.
  - C. Install pump pressure hose to fitting on pump (see Hydraulic Hose and Tube Installation in the General Information section of this chapter).

3. After installing the pump and connecting hydraulic hoses, install belt and adjust belt tension (see Operator's Manual).
4. Check oil level in transaxle. Add Dexron III ATF if necessary.
5. Start the engine and operate at idle speed until air is out of hydraulic system.
6. Stop the engine and recheck oil level in transaxle. Add Dexron III ATF if necessary.

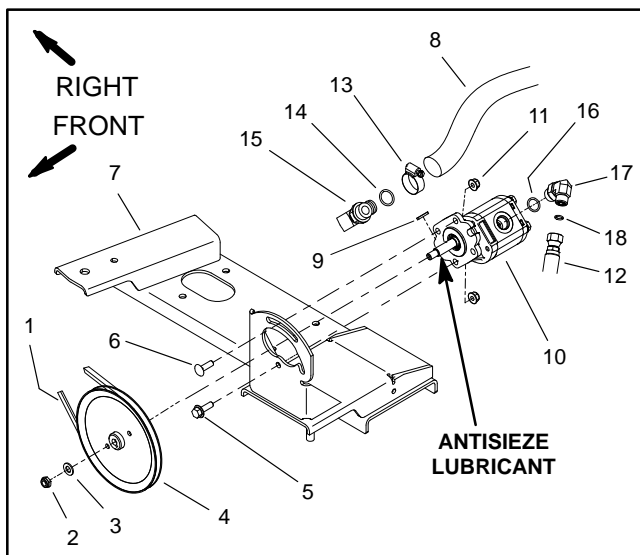

Figure 29

- |                      |                       |
|----------------------|-----------------------|
| 1. Drive belt        | 10. Gear pump         |
| 2. Lock nut          | 11. Lock nut (2)      |
| 3. Flat washer       | 12. Pressure hose     |
| 4. Pump pulley       | 13. Hose clamp        |
| 5. Flange head screw | 14. O-ring            |
| 6. Carriage screw    | 15. Hydraulic fitting |
| 7. Mount             | 16. O-ring            |
| 8. Suction hose      | 17. Hydraulic fitting |
| 9. Square key        | 18. O-ring            |

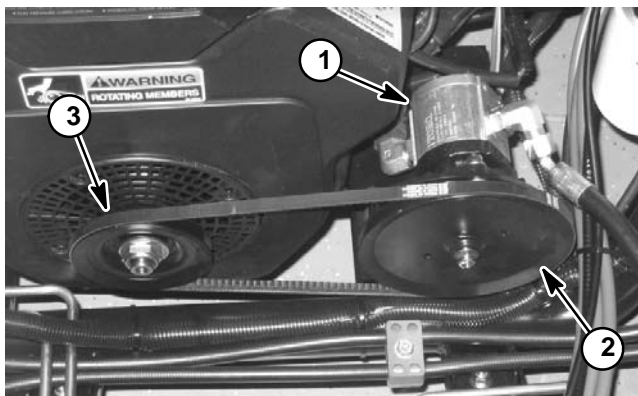

Figure 30

- |                |                  |
|----------------|------------------|
| 1. Gear pump   | 3. Engine pulley |
| 2. Pump pulley |                  |

This page is intentionally blank.

# Primary Hydraulic System Gear Pump Service

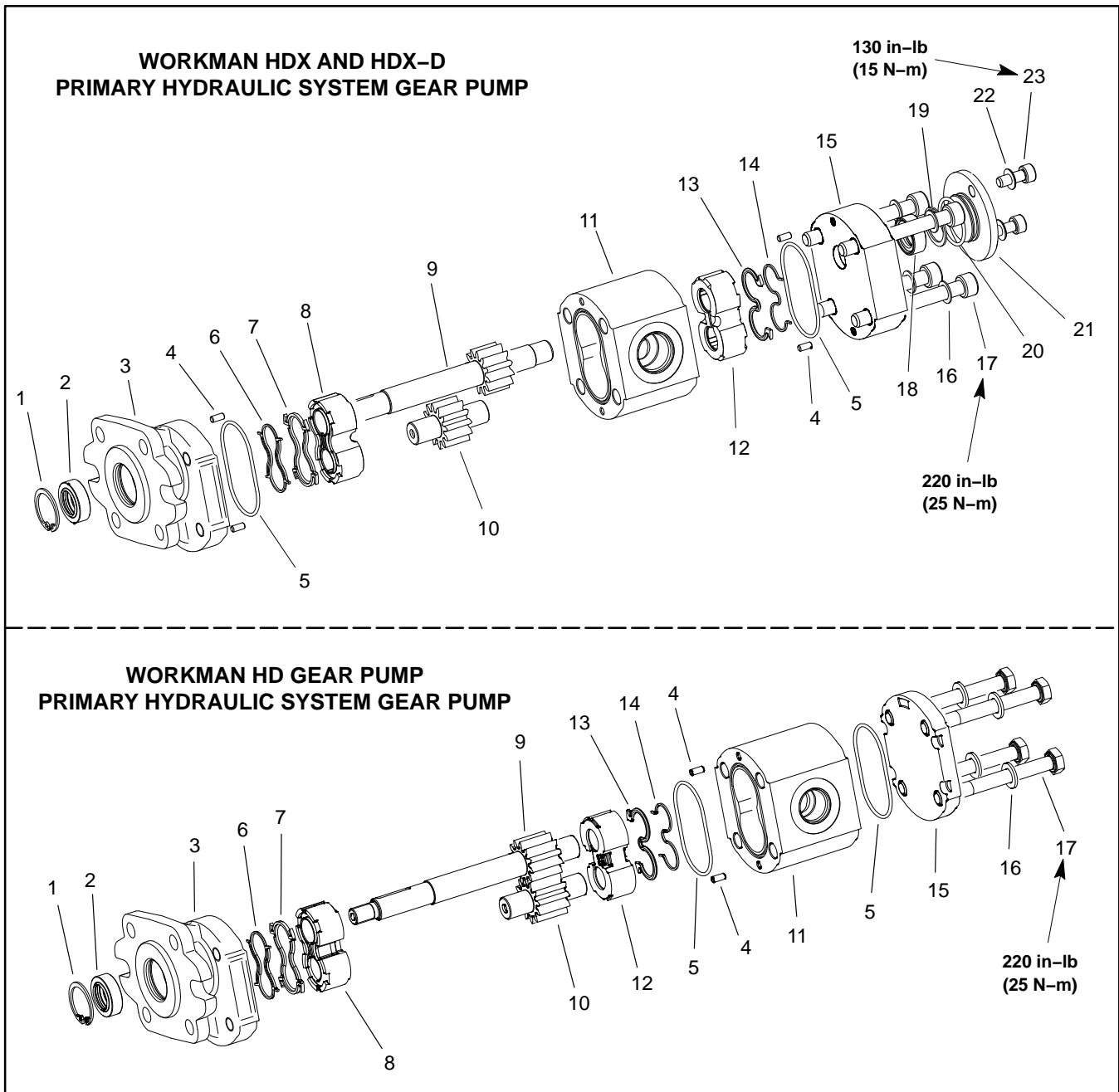

Figure 31

- |                       |                       |                           |
|-----------------------|-----------------------|---------------------------|
| 1. Retaining ring     | 9. Drive shaft        | 17. Screw (4)             |
| 2. Shaft seal         | 10. Idler shaft       | 18. Shaft seal            |
| 3. Front cover        | 11. Body              | 19. Retaining ring        |
| 4. Dowel pin          | 12. Rear thrust plate | 20. O-ring                |
| 5. O-ring (2)         | 13. Pressure seal     | 21. Cover                 |
| 6. Back-up seal       | 14. Back-up seal      | 22. Washer (2)            |
| 7. Pressure seal      | 15. Rear flange       | 23. Socket head screw (2) |
| 8. Front thrust plate | 16. Lock washer (4)   |                           |

**NOTE:** If vehicle is equipped with High Flow Hydraulics Kit, refer to High Flow Hydraulics System Gear Pump Service in this section.

**NOTE:** The Workman HDX and HDX–D gear pump includes a rear flange that will allow the installation of a second pump section for the High Flow Hydraulics Kit. The Workman HD gear pump does not have this type of rear flange.

### Disassembly (Fig. 31)

1. Plug pump ports and clean the outside of the pump thoroughly. After cleaning, remove plugs and drain any oil out of the pump.
2. Use a marker to make a **diagonal** line across the front thrust plate, body and rear flange for assembly purposes (Fig. 32).

**IMPORTANT: Prevent damage when clamping the gear pump in a vise; clamp on the front thrust plate only. Also, use a vise with soft jaws.**

3. Clamp front thrust plate of pump in a vise with soft jaws with the shaft end down.
4. On HDX and HDX–D pumps, remove socket head screws, washers and cover from rear flange.
5. Loosen, but do not remove, screws that secure rear flange to pump.
6. Remove pump from the vise and position pump so that the shaft end is facing down. Remove screws.
7. Carefully lift rear flange from body.
8. Carefully remove body. Lift body straight up to remove. Make sure the rear thrust plate remains on the drive and idler gear shafts. Locate and retrieve dowel pins.

**IMPORTANT: Note position of the open and closed side of the thrust plates before removing. Also, identify thrust plates (front and rear) with a marker for proper assembly.**

9. Carefully remove rear thrust plate, idler shaft, drive shaft and front thrust plate from the front cover.
10. Remove and discard O-rings, back-up seals and pressure seals from pump.

**IMPORTANT: Make sure to not damage the seal bores when removing the seal from the front cover and rear flange.**

11. Carefully remove retaining ring and shaft seal from both the front cover and rear flange (HDX and HDX–D). Discard seals.

### Inspection

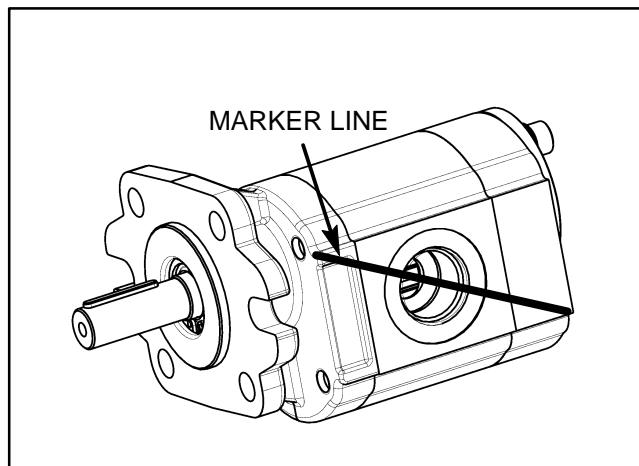

Figure 32



## CAUTION

**Use eye protection such as goggles when using compressed air.**

1. Remove any nicks and burrs from all parts with emery cloth.
2. Clean all parts with solvent. Dry all parts with compressed air.
3. Inspect drive and idler shafts for the following (Fig. 33):
  - A. Gear shafts should be free of rough surfaces and excessive wear at bushing points and sealing areas. Scoring, rough surfaces or wear on gear shafts indicates need for replacement.
  - B. Gear teeth should be free of excessive scoring and wear. Any broken or nicked gear teeth must be replaced.
  - C. Inspect gear face edge for sharpness. Sharp edges of gears will mill into wear plates and, thus, must be replaced.
4. Inspect thrust plates for the following:
  - A. Bearing areas should not have excessive wear or scoring.
  - B. Face of thrust plates that are in contact with gears should be free of wear, roughness or scoring.
  - C. Thickness of thrust plates should be equal.
5. Inspect front cover and rear flange for damage or wear.

## Assembly (Fig. 31)

**NOTE:** When assembling the pump, check the marker line on each part to make sure the pump components are properly aligned during assembly (Fig. 32).

1. Lubricate O-rings, pressure seals, back-up seals and thrust plate grooves with a thin coat of petroleum jelly. Lubricate all other internal parts freely with clean Dexron III ATF.

2. Install new seal into front cover and rear flange (HDX and HDX-D):

A. Press shaft seal into seal bore until it reaches the bottom of the bore.

B. Install retaining ring into the groove of the cover.

3. Install the lubricated pressure and backup seals into the grooves in the front and rear thrust plates. Install lubricated O-rings to the body.

4. Place front cover, seal side down, on a flat surface. Apply a light coating of petroleum jelly to the exposed side of the front cover.

5. Lubricate the drive shaft with clean Dexron III ATF. Carefully insert the drive end of the drive shaft through the front thrust plate with the pressure seal side down.

**IMPORTANT: When installing drive shaft into front cover, make sure that shaft seal (item 2) is not damaged.**

6. Carefully install shaft with front thrust plate into front cover taking care to not damage shaft seal.

7. Lubricate the idler shaft with clean Dexron III ATF. Install idler shaft into the remaining position in the front thrust plate. Apply a light coating of clean hydraulic oil to gear faces.

8. Install rear thrust plate with pressure seal side up and open side of the seals pointing to the inlet side of the pump.

9. Install two (2) dowel pins into front cover. Align marker line on the body and front cover.

**IMPORTANT: Do not dislodge seals during installation.**

10. Gently slide the body onto the assembly. Firm hand pressure should be sufficient to engage the dowel pins.

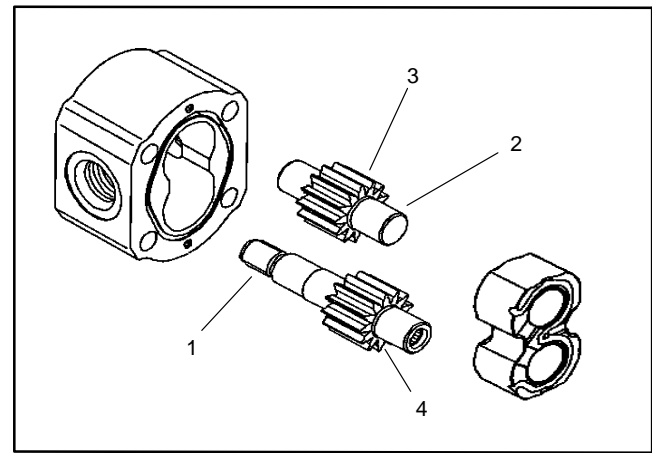

Figure 33

- |                      |                   |
|----------------------|-------------------|
| 1. Gear shaft spline | 3. Gear teeth     |
| 2. Gear shaft        | 4. Gear face edge |

11. Install two (2) dowel pins into body (HDX and HDX-D).

12. Align marker line on the body and rear flange.

**IMPORTANT: When installing rear flange on HDX and HDX-D pumps, make sure that shaft seal (item 18) is not damaged.**

13. Carefully install rear flange onto pump assembly.

14. Install the four (4) screws with lock washers and hand tighten.

**IMPORTANT: Prevent damage when clamping the pump into a vise; clamp on the front cover only. Also, use a vise with soft jaws.**

15. Place front cover of the pump into a vise with soft jaws and alternately torque the cap screws **220 in-lb (25 N-m)**.

16. On HDX and HDX-D pumps, lubricate O-ring with a thin coat of petroleum jelly and install on cover. Install cover to rear flange and secure with two (2) socket head screws. Torque screws **130 in-lb (15 N-m)**.

17. Remove pump from vise.

18. Place a small amount of clean Dexron III ATF in the inlet of the pump and rotate the drive shaft away from the inlet one revolution. If any binding is noted, disassemble the pump and check for assembly problems.



This page is intentionally blank.

# High Flow Hydraulic System Gear Pump Service

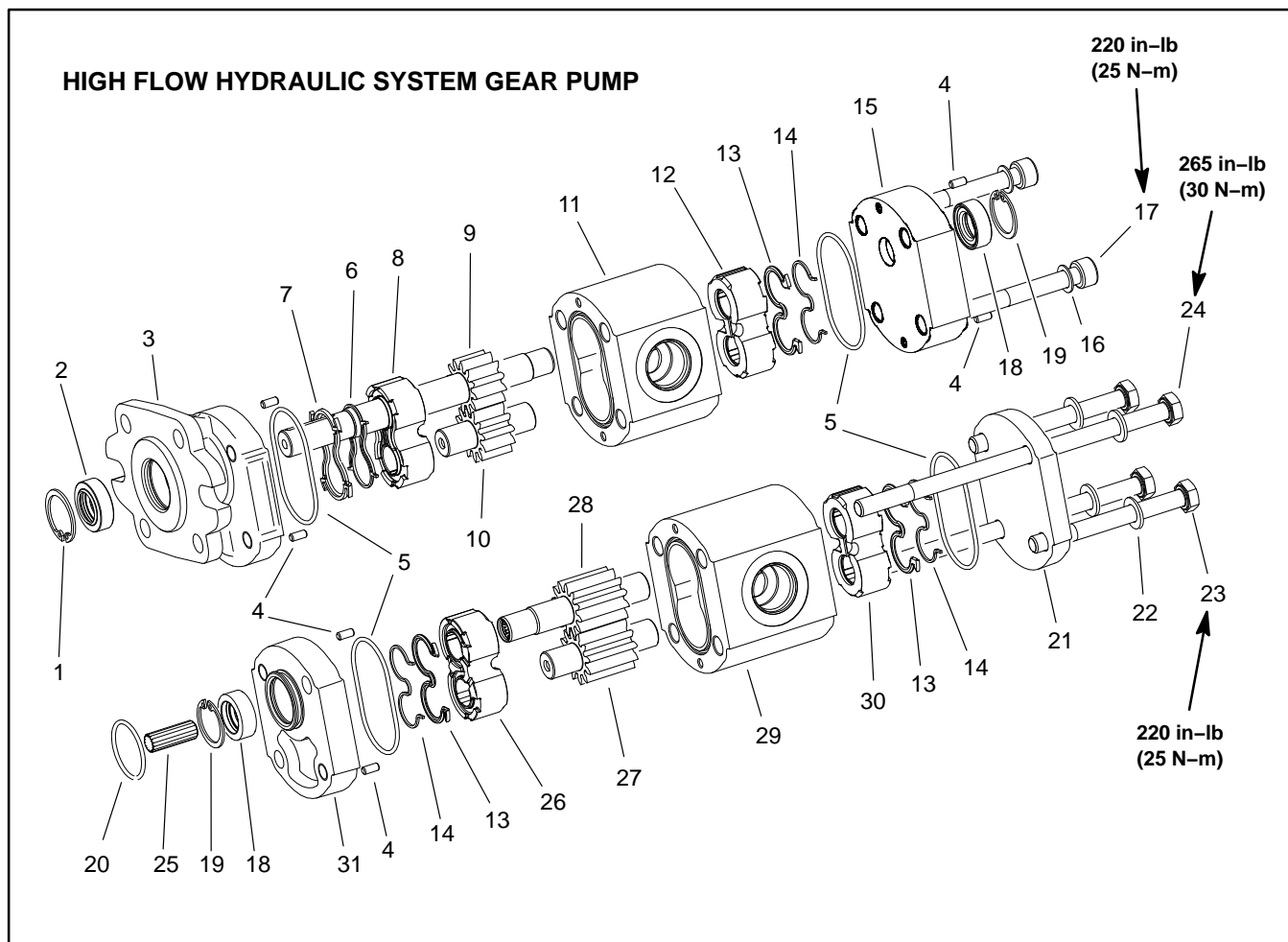

Figure 34

- |                   |                           |                            |
|-------------------|---------------------------|----------------------------|
| 1. Retaining ring | 12. Thrust plate          | 22. Washer (4)             |
| 2. Shaft seal     | 13. Pressure seal         | 23. Cap screw (4)          |
| 3. Front cover    | 14. Back-up seal          | 24. Cap screw (2)          |
| 4. Dowel pin (6)  | 15. Rear flange           | 25. Coupler                |
| 5. O-ring (4)     | 16. Lock washer (2)       | 26. Thrust plate           |
| 6. Back-up seal   | 17. Socket head screw (2) | 27. Idler shaft            |
| 7. Pressure seal  | 18. Shaft seal            | 28. Drive shaft            |
| 8. Thrust plate   | 19. Retaining ring        | 29. Rear pump section body |
| 9. Drive shaft    | 20. O-ring                | 30. Thrust plate           |
| 10. Idler shaft   | 21. Rear cover            | 31. Front flange           |

The two section gear pump assembly used on Workman HDX and HDX-D vehicle equipped with the High Flow Hydraulics Kit is shown (Fig. 34). The first section of the pump (drive end) is identical in form and function to the Primary Hydraulic System Gear Pump. When servicing this gear pump, follow the procedure for the Primary Hydraulic System Gear Pump Service in this section and observe the following:

1. Do not mix components from one pump section to the other.

2. The two section High Flow Hydraulic System gear pump supplies oil flow for two circuits and uses two separate reservoirs and oil types (Fig. 35). The front pump section (drive end) uses oil from the transaxle (Dexron III ATF). The rear pump section uses oil from the High Flow Hydraulics Kit reservoir (hydraulic oil). During gear pump assembly, lubricate front section components with clean Dexron III ATF and rear section components with clean hydraulic oil.

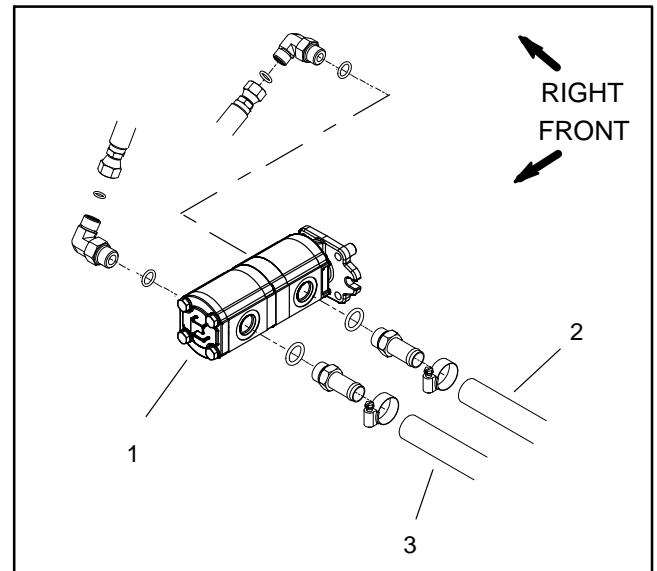

Figure 35

1. Gear pump
2. Suction hose from transaxle (Dexron III ATF)
3. Suction hose from reservoir (hydraulic oil)

# Lift Valve

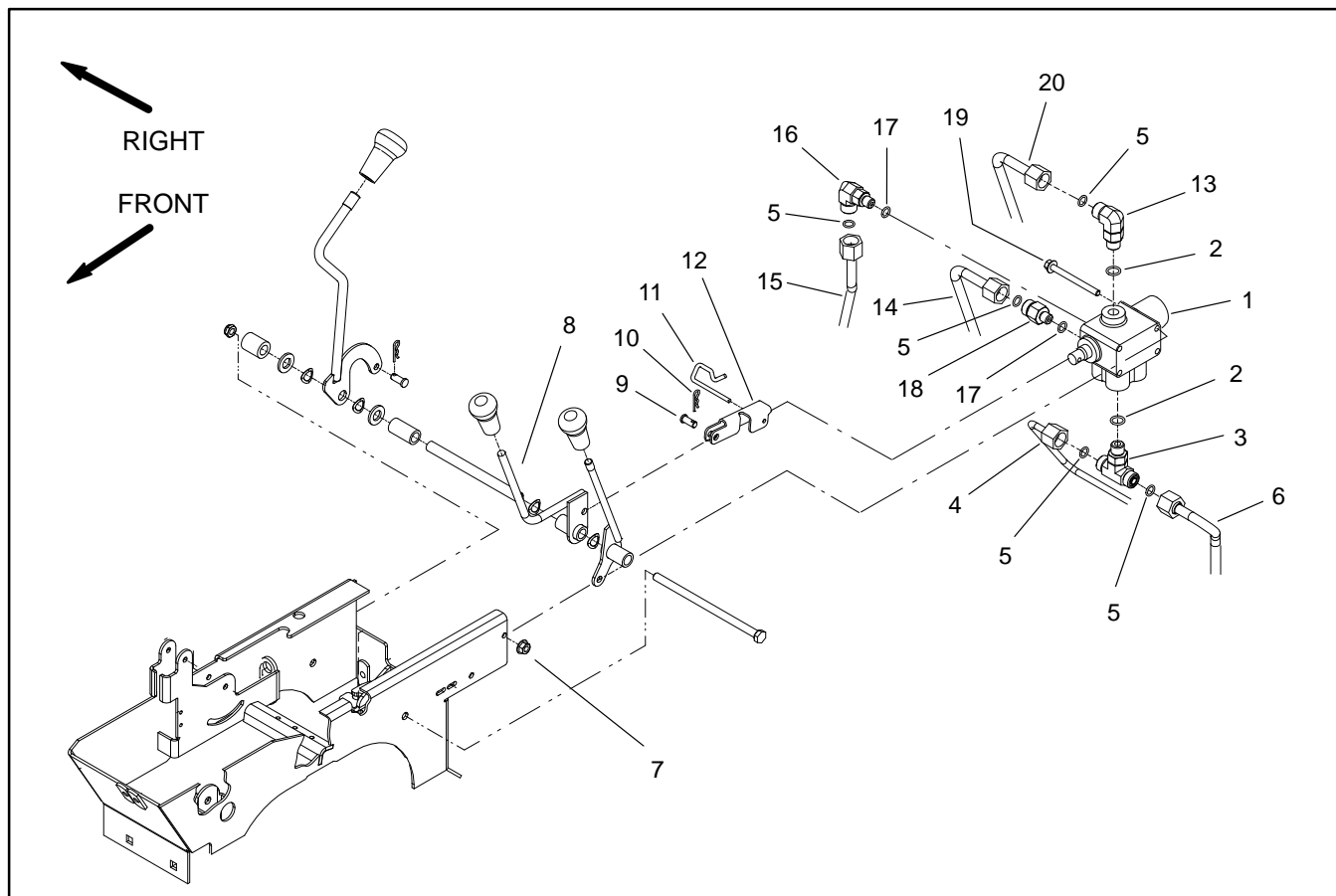



Figure 36

- |   |                                       |   |
|---|---------------------------------------|---|
| 1. Lift valve                             | 8. Lift lever                         | 15. Hyd. tube (to female quick fitting) |
| 2. O-ring                                 | 9. Clevis pin                         | 16. 90 hydraulic fitting                |
| 3. Tee fitting                            | 10. Hairpin                           | 17. O-ring                              |
| 4. Hyd. tube (steering circuit return)    | 11. Retainer pin                      | 18. Hydraulic adapter                   |
| 5. O-ring                                 | 12. Link                              | 19. Flange head screw (2)               |
| 6. Hyd. tube (return to hydraulic filter) | 13. 90 hydraulic fitting              | 20. Hyd. tube (pressure supply)         |
| 7. Flange nut (2)                         | 14. Hyd. tube (to male quick fitting) |   |

### Removal (Fig. 36)

1. Park vehicle on a level surface, raise and support bed (if installed), shut engine off and engage the parking brake. Remove key from the ignition switch.
2. Remove seat base from vehicle (see Seat Base Removal in Chapter 7 – Chassis in this manual).
3. Read the General Precautions for Removing and Installing Hydraulic System Components at the beginning of this chapter section.

	<b>CAUTION</b>
<b>Before performing any service or repair on hydraulic system components, relieve system pressure to avoid injury from pressurized hydraulic oil. Stop the engine, remove key from the ignition switch, rotate the steering wheel in both directions, lower or support the bed and operate other hydraulic accessories.</b>	

4. Label and disconnect hydraulic hoses from lift valve. Install caps or plugs in hoses to prevent contamination and leakage of hydraulic oil. Install plugs in valve ports.
5. Remove lift valve from vehicle.
6. If hydraulic fittings are to be removed from lift valve, mark fitting orientation to allow correct assembly. Remove fittings from valve and discard O-rings.

### Installation (Fig. 36)

1. If fittings were removed from lift valve, lubricate and place new O-rings onto fittings. Install fittings into valve openings using marks made during the removal process to properly orientate fittings. Tighten fittings (see Hydraulic Fitting Installation in the General Information section of this chapter).
2. Install lift valve to vehicle.

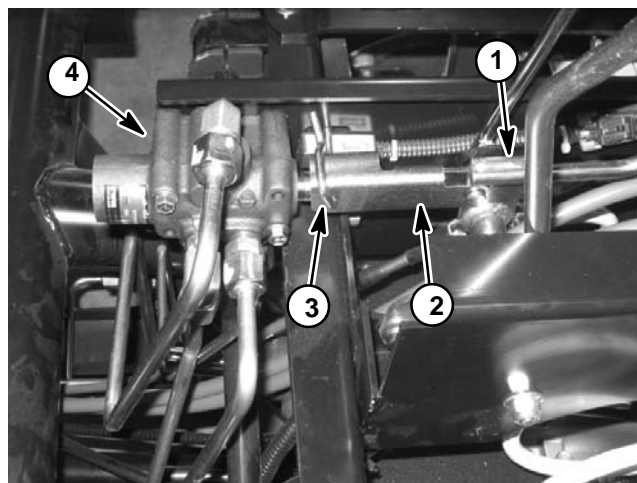

Figure 37

- |               |                 |
|---------------|-----------------|
| 1. Lift lever | 3. Retainer pin |
| 2. Link       | 4. Lift valve   |

3. Replace O-rings on hydraulic hoses and fittings. Remove caps and plugs from hoses and fittings. Connect hydraulic hoses to lift valve (see Hydraulic Hose and Tube Installation in the General Information section of this chapter).
4. Install seat base to vehicle (see Seat Base Installation in Chapter 7 – Chassis in this manual). Make sure that lift lever can be moved in control plate slot to allow correct operation of lift lock.
5. Check oil level in transaxle. Add Dexron III ATF if necessary.
6. Start the engine, operate at idle speed and operate the lift lever in both directions until air is out of hydraulic system.
7. Stop the engine and recheck oil level in transaxle. Add Dexron III ATF if necessary.
8. On TC models, verify correct operation of lift lever interlock switch.

## Lift Valve Service

### Disassembly (Fig. 38)

1. After removing lift valve from vehicle, wash valve in solvent and dry thoroughly.
2. Carefully mount lift valve in a vise so that mounting pads are against jaws of vise. Lift valve spool retaining ring should be facing up.
3. Remove two (2) hex cap plugs from side of valve body. Inside valve body, behind each hex cap plug, there is a spring, ball and cam pin; remove these parts.

**NOTE:** Remove check ball seats only if they need replacement; the seats are press fit into the valve body.

4. Remove retaining ring from spool. Remove spool retaining ring, spring retainer, spacer, spring and second spool retaining ring. Carefully push and twist spool to remove spool from valve body.

**IMPORTANT:** When removing O-rings from valve body, be very careful to not scratch valve bore finish.

5. Use a hooked scribe or thin screwdriver to remove O-rings from inside bore of valve body. These O-rings are the seals for the spool.
6. Inspect all components for wear, paying special attention to the spool. Signs of wear on one side of the spool may indicate a bent spool. Inspect the spool for flatness and replace if necessary.

### Assembly (Fig. 38)

1. Clean all components thoroughly before assembly. Use new O-rings when assembling lift valve.
2. Coat all O-rings and spool with clean Dexron III ATF before installation into valve body. Assemble components in reverse order of disassembly. Install spool into valve body before inserting cam pins, balls, springs and hex cap plugs.

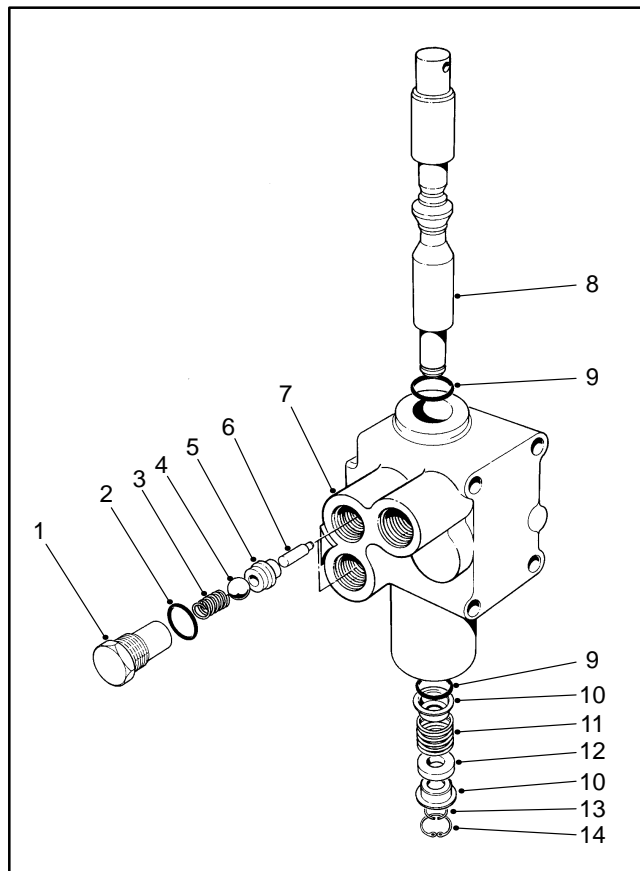

Figure 38

- |                        |                          |
|------------------------|--------------------------|
| 1. Hex cap plug (2)    | 8. Spool                 |
| 2. O-ring (2)          | 9. O-ring                |
| 3. Spring (2)          | 10. Spring retainer      |
| 4. Check ball (2)      | 11. Spring               |
| 5. Check ball seat (2) | 12. Spacer               |
| 6. Cam pin (2)         | 13. Spool retaining ring |
| 7. Valve body          | 14. Retaining ring       |

This page is intentionally blank.

# Steering Control Valve

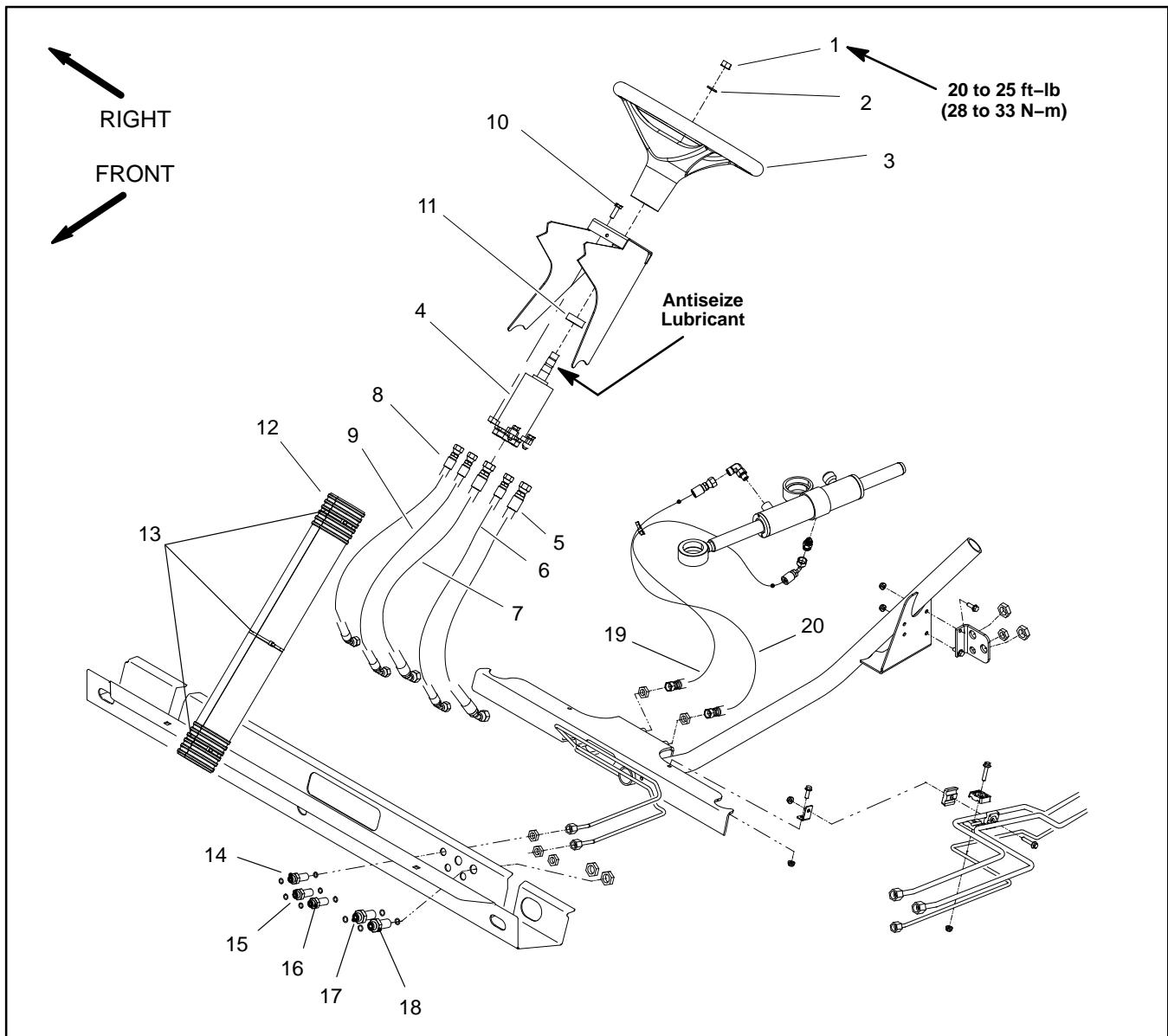

Figure 39

- |                                       |  |  |
|---------------------------------------|--|--|
| 1. Lock nut                           | 8. Hyd hose (to control valve L port)  | 15. Bulkhead fitting (to valve R port) |
| 2. Flat washer                        | 9. Hyd hose (to control valve R port)  | 16. Bulkhead fitting (to valve T port) |
| 3. Steering wheel                     | 10. Cap screw (4)                      | 17. Bulkhead fitting (to valve P port) |
| 4. Steering control valve             | 11. Dust cover                         | 18. Bulkhead fitting (to valve E port) |
| 5. Hyd hose (to control valve E port) | 12. Steering hose cover                | 19. Hyd hose (to steer cyl shaft end)  |
| 6. Hyd hose (to control valve T port) | 13. Cable tie                          | 20. Hyd hose (to steer cyl barrel end) |
| 7. Hyd hose (to control valve P port) | 14. Bulkhead fitting (to valve L port) |  |

## Removal (Fig. 39)

1. Park vehicle on a level surface, shut engine off and engage the parking brake. Remove key from the ignition switch.

2. Remove steering wheel (see Steering Wheel Removal in Chapter 7 – Chassis in this manual).

3. Remove cable ties that secure steering hose cover to hydraulic hoses. Remove cover from hoses.

4. Read the General Precautions for Removing and Installing Hydraulic System Components at the beginning of this chapter section.





## CAUTION

Before performing any service or repair on hydraulic system components, relieve system pressure to avoid injury from pressurized hydraulic oil. Stop the engine, remove key from the ignition switch, rotate the steering wheel in both directions, lower or support the bed and operate other hydraulic accessories.

5. Remove hood to gain access to steering control (see Hood Removal in Chapter 7 – Chassis in this manual).
6. Remove four (4) cap screws that secure steering control valve to vehicle frame. Move steering valve (with hydraulic hoses attached) away from vehicle frame.
7. Label and disconnect hydraulic hoses from steering control valve (Fig. 40 and 41). Install caps or plugs in hoses and valve fittings to prevent contamination and leakage of hydraulic oil.

### Installation (Fig. 39)

1. Replace O-rings on hydraulic fittings. Remove caps and plugs from hoses. Connect hydraulic hoses to correct steering control valve ports (Fig. 40 and 41) (see Hydraulic Hose and Tube Installation in this chapter). Make sure that hoses are not twisted while tightening.
2. Position steering control valve to vehicle frame with port R toward front of vehicle (Fig. 40). Secure steering control valve to vehicle with four (4) cap screws.
3. Install hydraulic hose cover over hoses and secure with cable ties.
4. Install hood to frame (see Hood Installation in Chapter 7 – Chassis in this manual).
5. Install steering wheel (see Steering Wheel Installation in Chapter 7 – Chassis in this manual).
6. Check oil level in transaxle (see vehicle Operator's Manual). Add Dexron III ATF if necessary.
7. Start the engine, operate at idle speed and rotate the steering wheel in both directions until air is out of hydraulic system.
8. Stop the engine and check oil level in transaxle. Add Dexron III ATF if necessary.

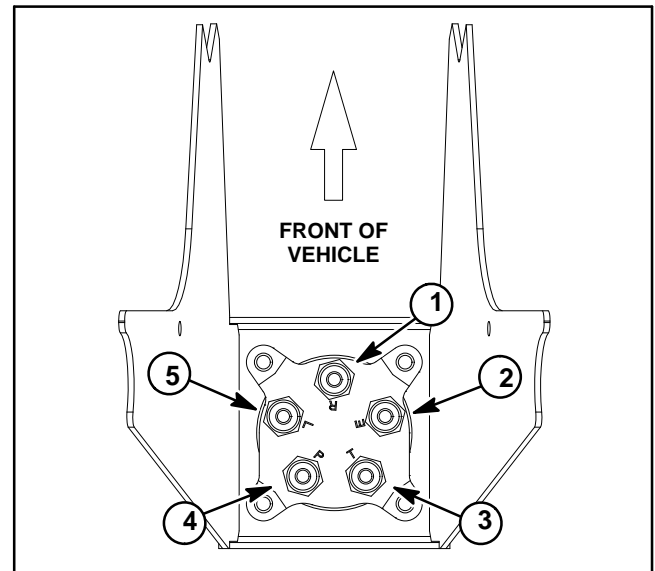

Figure 40

- |           |           |
|-----------|-----------|
| 1. R port | 4. P port |
| 2. E port | 5. L port |
| 3. T port |           |

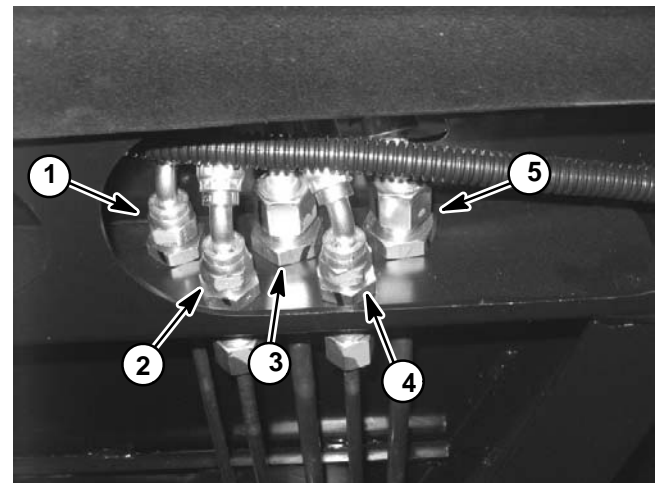

Figure 41

- |                       |                       |
|-----------------------|-----------------------|
| 1. Hyd hose to L port | 4. Hyd hose to T port |
| 2. Hyd hose to R port | 5. Hyd hose to E port |
| 3. Hyd hose to P port |                       |

## Steering Control Valve Service

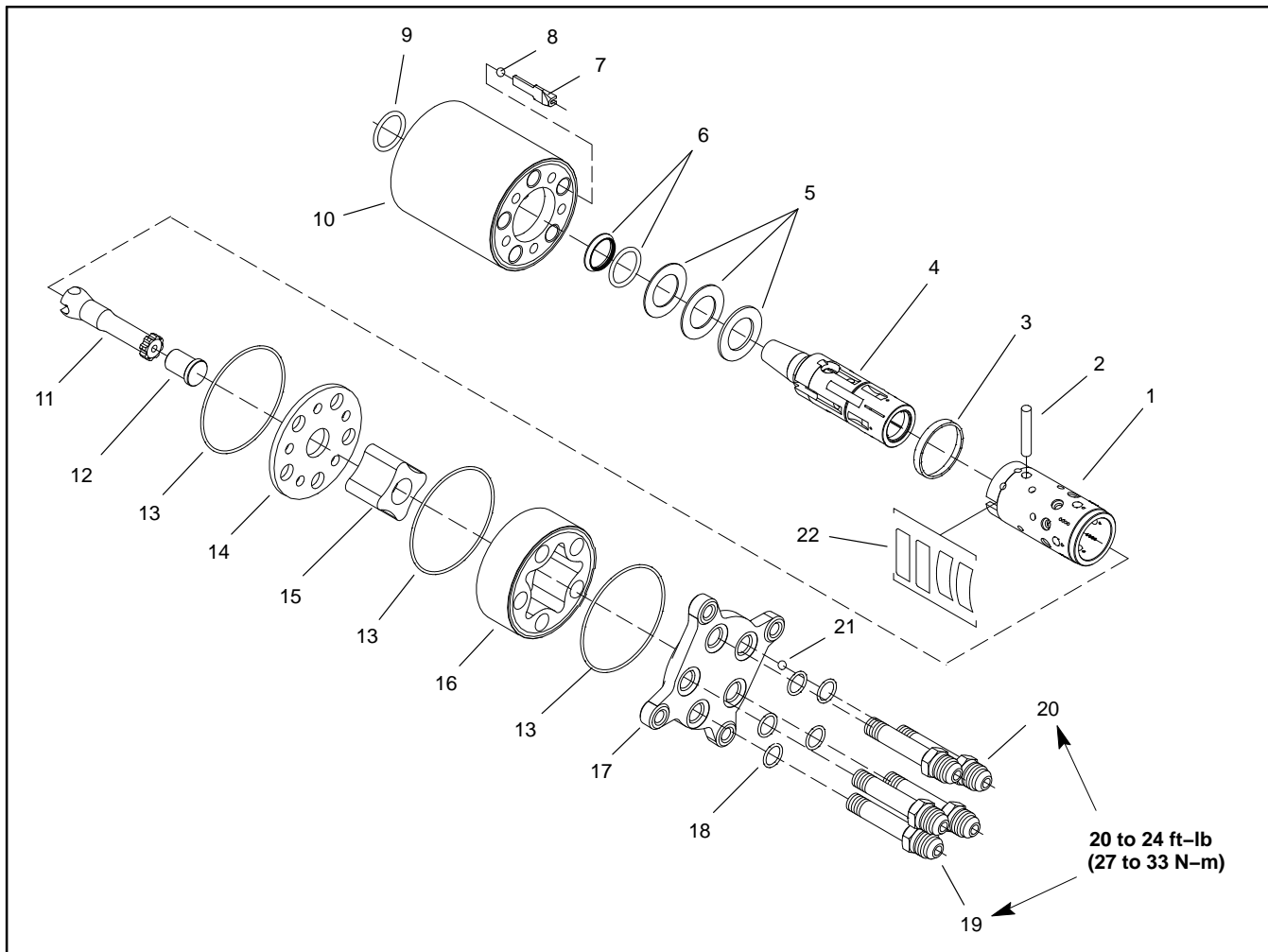

Figure 42

- |                     |                        |                                   |
|---------------------|------------------------|-----------------------------------|
| 1. Sleeve           | 9. Dust seal ring      | 16. Outer gearwheel               |
| 2. Cross pin        | 10. Housing            | 17. End cover                     |
| 3. Ring             | 11. Cardan shaft       | 18. O-ring (5)                    |
| 4. Spool            | 12. Spacer             | 19. Screw/fitting (ports L, R, T) |
| 5. Bearing assembly | 13. O-ring             | 20. Screw/fitting (ports P and E) |
| 6. Shaft seal       | 14. Distribution plate | 21. P port check ball             |
| 7. Ball stop        | 15. Inner gearwheel    | 22. Spring set                    |
| 8. Ball             |                        |                                   |

**NOTE:** For service of the steering control valve, see the Sauer/Danfoss Steering Unit Type OSPM Service Manual at the end of this chapter.

This page is intentionally blank.

# Steering Cylinder

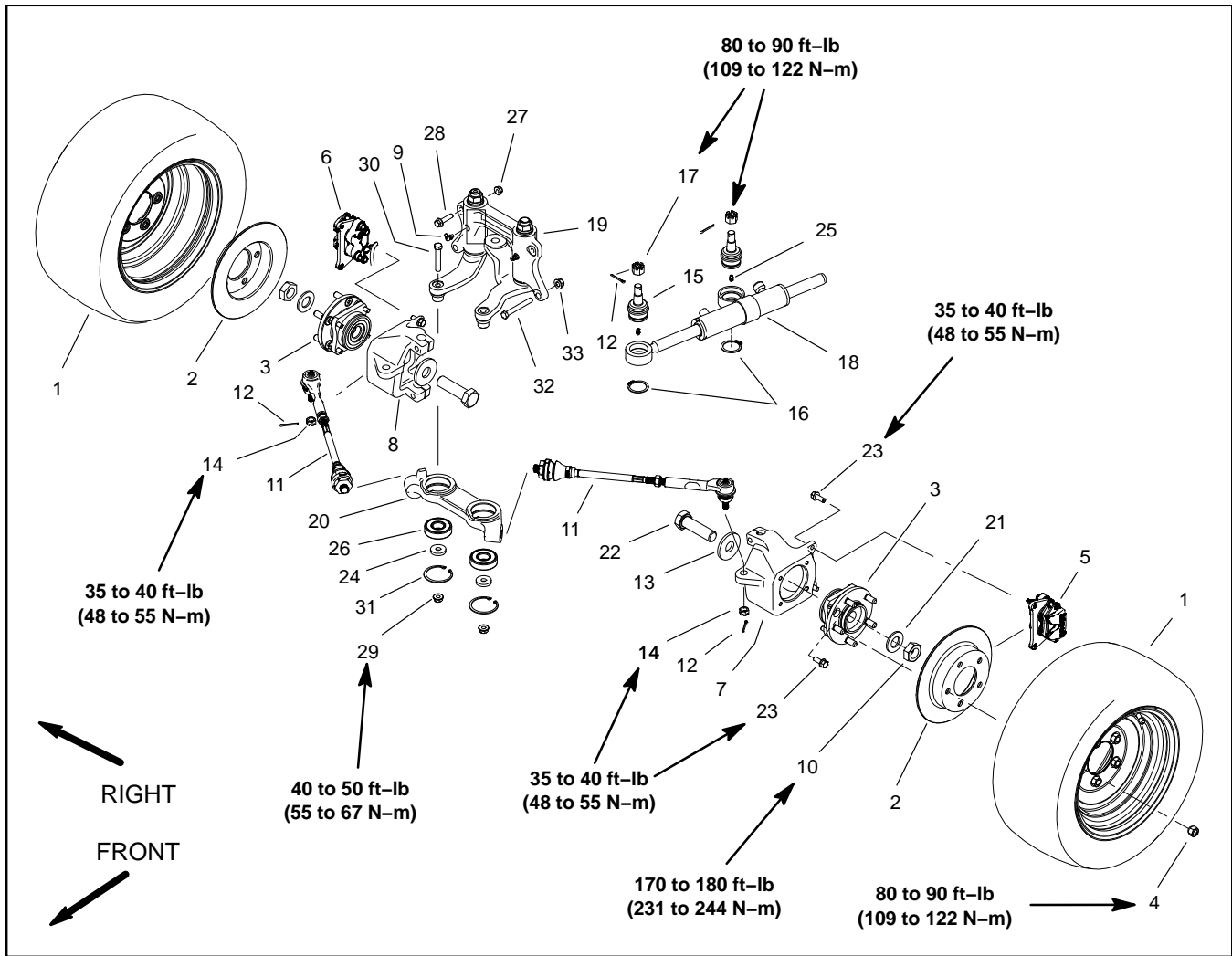



Figure 43

- |   |  |   |
|---|--|---|
| <ul style="list-style-type: none"> <li>1. Front wheel assembly</li> <li>2. Brake rotor</li> <li>3. Wheel hub assembly</li> <li>4. Lug nut (5 per wheel)</li> <li>5. LH brake caliper</li> <li>6. RH brake caliper</li> <li>7. LH knuckle</li> <li>8. RH knuckle</li> <li>9. Grease fitting (2)</li> <li>10. Lock nut (2)</li> <li>11. Tie rod assembly</li> </ul> | <ul style="list-style-type: none"> <li>12. Cotter pin (4)</li> <li>13. Hardened washer (2)</li> <li>14. Slotted hex nut</li> <li>15. Ball joint (2)</li> <li>16. Retaining ring</li> <li>17. Slotted hex nut (2)</li> <li>18. Steering cylinder</li> <li>19. Steering linkage assembly</li> <li>20. Center link</li> <li>21. Flat washer (2)</li> <li>22. Cap screw (2)</li> </ul> | <ul style="list-style-type: none"> <li>23. Flange head screw (12)</li> <li>24. Washer (2)</li> <li>25. Grease fitting (2)</li> <li>26. Ball bearing (2)</li> <li>27. Flange nut (2)</li> <li>28. Flange head bolt (2)</li> <li>29. Flange nut (2)</li> <li>30. Cap screw (2)</li> <li>31. Snap ring (2)</li> <li>32. Cap screw (2)</li> <li>33. Lock nut (2)</li> </ul> |
|---|--|---|

### Removal (Fig. 43)

1. Park vehicle on a level surface, shut engine off and engage the parking brake. Remove key from the ignition switch.
2. Read the General Precautions for Removing and Installing Hydraulic System Components at the beginning of this chapter section.

**CAUTION**

**Before performing any service or repair on hydraulic system components, relieve system pressure to avoid injury from pressurized hydraulic oil. Stop the engine, remove key from the ignition switch, rotate the steering wheel in both directions, lower or support the bed and operate other hydraulic accessories.**

3. Label and disconnect hydraulic hoses from steering cylinder. Install caps or plugs in hoses to prevent contamination and leakage of hydraulic oil. Install plugs in cylinder ports.
4. Remove steering cylinder from vehicle.
5. If hydraulic fittings are to be removed from steering cylinder, mark fitting orientation to allow correct assembly. Remove fittings from cylinder and discard O-rings (Fig. 44).

### Installation (Fig. 43)

1. If fittings were removed from steering cylinder, lubricate and place new O-rings onto fittings. Install fittings into cylinder openings using marks made during the removal process to properly orientate fittings. Tighten fittings (see Hydraulic Fitting Installation in this chapter).
2. Install steering cylinder to vehicle.

3. Remove caps and plugs from hoses and fittings. Install new O-rings on hydraulic fittings. Connect hydraulic hoses to steering cylinder (see Hydraulic Hose and Tube Installation in this chapter).
4. Check oil level in transaxle (see vehicle Operator's Manual). Add Dexron III ATF if necessary.
5. Start the engine, operate at idle speed and rotate the steering wheel in both directions until air is out of hydraulic system.
6. Stop the engine and check oil level in transaxle. Add Dexron III ATF if necessary.
7. Check front wheel alignment and adjust as needed (see Front Wheel Alignment in Chapter 7 – Chassis in this manual).

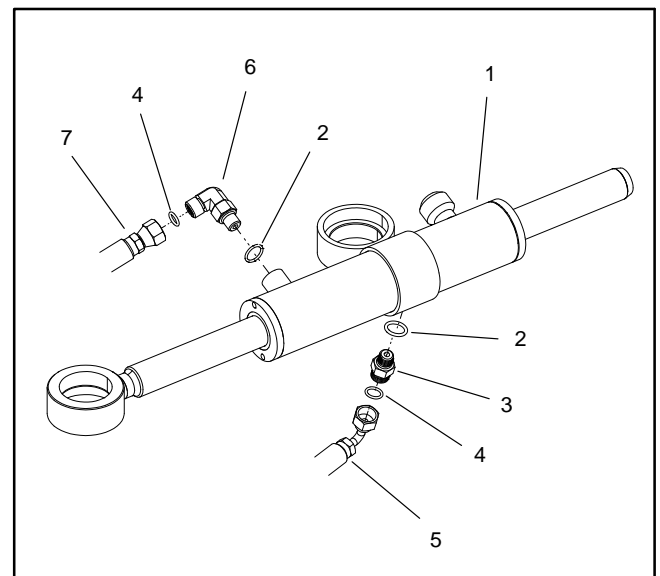

Figure 44

- |                      |                         |
|----------------------|-------------------------|
| 1. Steering cylinder | 5. Hydraulic hose       |
| 2. O-ring            | 6. 90 hydraulic fitting |
| 3. Hydraulic fitting | 7. Hydraulic hose       |
| 4. O-ring            |                         |

## Steering Cylinder Service

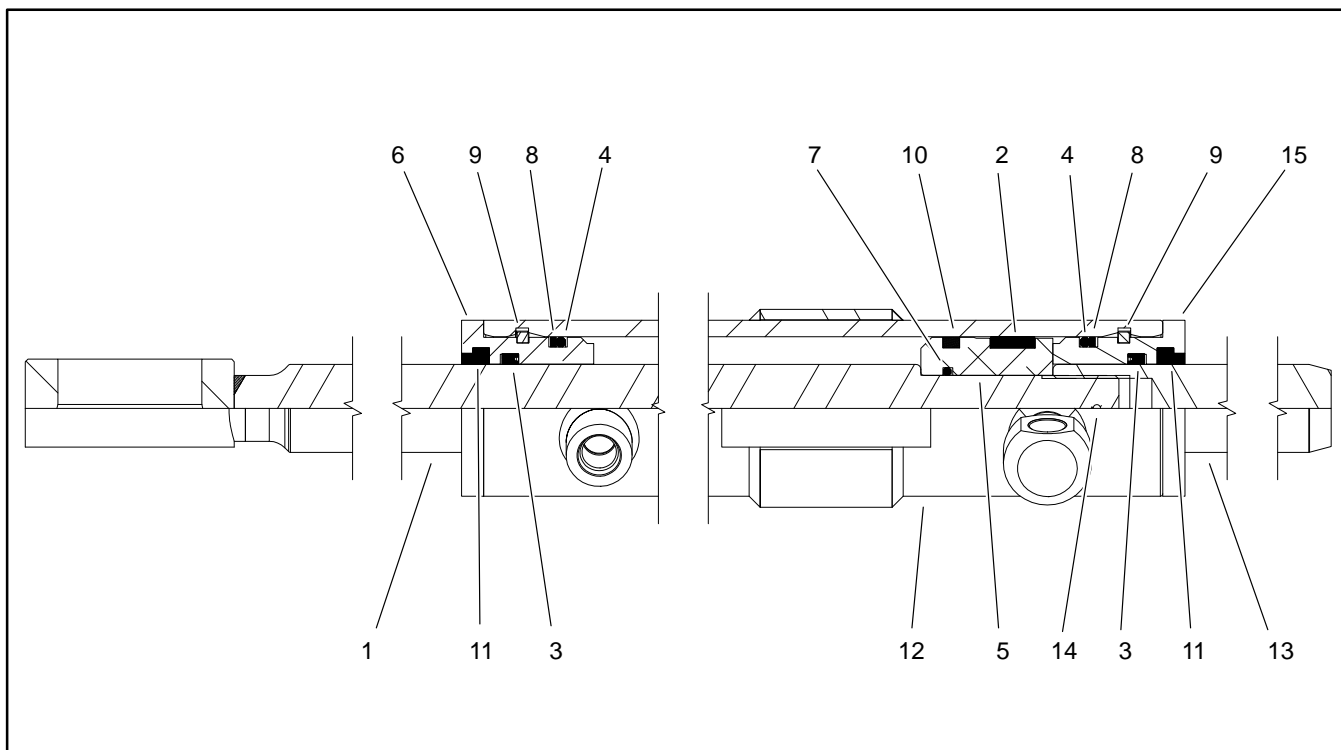

Figure 45

- |               |                   |                 |
|---------------|-------------------|-----------------|
| 1. Rear shaft | 6. Rear head      | 11. Dust seal   |
| 2. Wear ring  | 7. O-ring         | 12. Barrel      |
| 3. Seal       | 8. Back-up ring   | 13. Front shaft |
| 4. O-ring     | 9. Retaining ring | 14. Roll pin    |
| 5. Piston     | 10. Seal          | 15. Front head  |

### Disassembly (Fig. 45)

1. Pump oil out of cylinder into a drain pan by slowly moving piston back and forth.
2. Before disassembling cylinder, plug ports, wash exterior with cleaning solvent and dry thoroughly.

**IMPORTANT: Prevent damage when clamping the cylinder's barrel into a vise; clamp on the clevis only. Do not close vise on barrel.**

3. Mount steering cylinder in a vise equipped with soft jaws by clamping on the barrel clevis.

4. Remove retaining rings that secure both heads in barrel.

A. Use a spanner wrench to rotate head clockwise until the edge of the retaining ring appears in the barrel opening.

B. Insert a screwdriver under the beveled edge of the retaining ring to start the retaining ring through the opening.

C. Rotate the head counter-clockwise to remove retaining ring from barrel and head.

5. Use a twisting and pulling motion to carefully extract the front head assembly from the barrel.

6. Grasp end of rear shaft and use a twisting and pulling motion to carefully extract the rear shaft, rear head, front shaft and piston assembly from the barrel.

7. Remove cylinder from vise.

**IMPORTANT: When removing roll pin from front and rear shafts, make sure that shaft surfaces are not damaged.**

8. Remove roll pin that secures front shaft to rear shaft, then remove front shaft, piston and rear head from rear shaft. Retain the  $\frac{1}{8}$ " x  $\frac{7}{8}$ " roll pin for reassembly.

9. Remove and discard seals, O-rings and wear ring from piston and heads.

## Inspection

1. Wash all cylinder parts in clean solvent. Dry parts with compressed air. Do not wipe parts dry with paper towels or cloth. Lint in the hydraulic system will cause damage.
2. Carefully inspect internal surface of barrel for damage (deep scratches, out-of-round, etc.).
3. Inspect shaft and piston for evidence of excessive scoring, pitting or wear.
4. Replace steering cylinder if internal components are found to be worn or damaged.

## Assembly (Fig. 45)

1. Use a new seal kit to replace all seals, O-rings and wear ring to piston and heads. Apply clean Dexron III ATF to all seal kit components before installing.
2. Install rear head with new seals onto rear shaft.

**IMPORTANT: Make sure to not damage O-ring as piston is installed over roll pin hole in rear shaft.**

3. Install piston with new seals and back-ups onto rear shaft.

**IMPORTANT: When installing roll pin into front and rear shafts, make sure that shaft surfaces are not damaged.**

4. Slide front shaft onto rear shaft and align roll pin holes in shafts. Install the  $\frac{1}{8}$ " x  $\frac{7}{8}$ " roll pin to secure shafts.

**IMPORTANT: Prevent damage when clamping the cylinder's barrel into a vise; clamp on the clevis only. Do not close vise on barrel.**

5. Mount steering cylinder in a vise equipped with soft jaws by clamping on the barrel clevis.
6. Coat all cylinder components with clean Dexron III ATF. Slide shaft assembly into barrel, being careful to not damage seals during installation.
7. Insert front head assembly into the barrel being careful to not damage head seals during installation.
8. Secure front and rear heads in barrel with retaining rings.
  - A. Align retaining ring hole in the head with the access slot in the barrel.
  - B. Insert the retaining ring hook into the hole and rotate head clockwise until the retaining ring is completely pulled into the barrel and the ring ends are covered.
  - C. Apply silicone sealer to tube access slot.

# Lift Cylinder

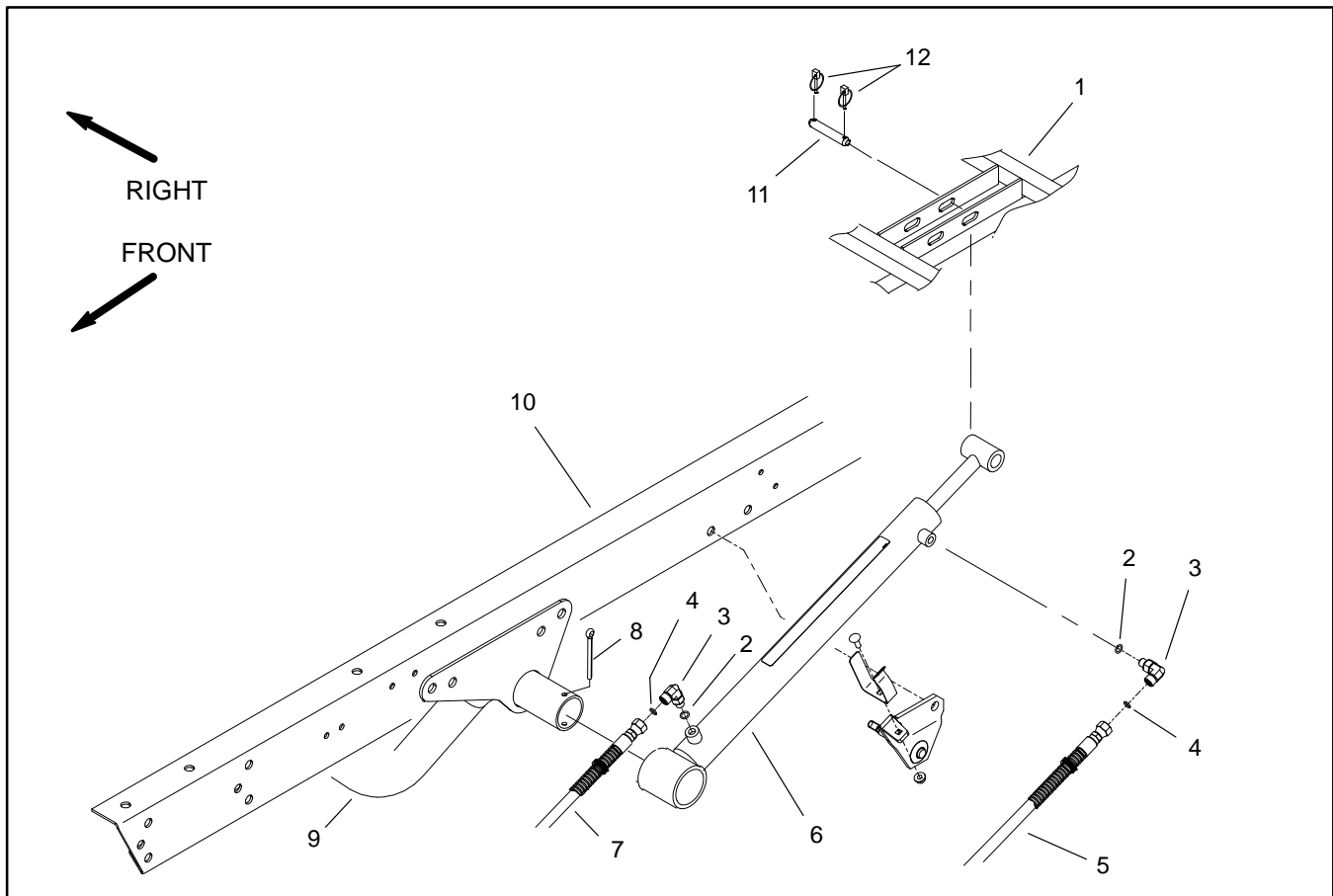

Figure 46

- |                          |                             |                           |
|--------------------------|-----------------------------|---------------------------|
| 1. Bed frame             | 5. Hydraulic hose           | 9. Engine support         |
| 2. O-ring                | 6. Lift cylinder (LH shown) | 10. Frame rail (LH shown) |
| 3. 90° hydraulic fitting | 7. Hydraulic hose           | 11. Clevis pin            |
| 4. O-ring                | 8. Cotter pin               | 12. Lynch pin             |



## Removal (Fig. 46)

1. Park vehicle on a level surface, lower bed until clevis pins that secure lift cylinder to bed are loose in the bed slots. Shut engine off and engage the parking brake. Remove key from the ignition switch.
2. Read the General Precautions for Removing and Installing Hydraulic System Components at the beginning of this chapter section.

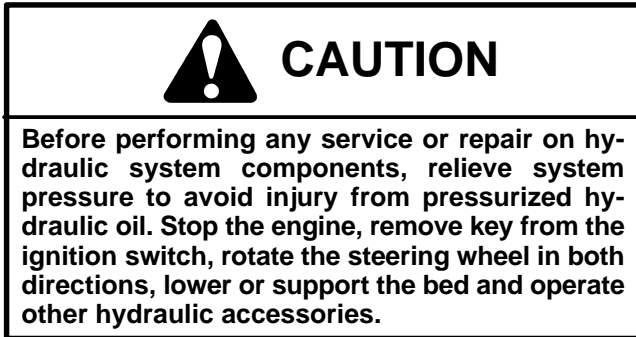

3. Disconnect hydraulic hoses from lift cylinder. Install caps or plugs in hoses to prevent contamination and leakage of hydraulic oil. Install plugs in cylinder ports.
4. Remove lynch pin and clevis pin that secure lift cylinder to bed.
5. Remove cotter pin that secures lift cylinder to engine support.
6. Remove lift cylinder from vehicle.
7. If hydraulic fittings are to be removed from lift cylinder, mark fitting orientation to allow correct assembly. Remove fittings from cylinder and discard O-rings.

## Installation (Fig. 46)

1. If fittings were removed from lift cylinder, lubricate and place new O-rings onto fittings. Install fittings into cylinder openings using marks made during the removal process to properly orientate fittings. Tighten fittings (see Hydraulic Fitting Installation in this chapter).
2. Make sure that lift cylinder is fully retracted.
3. Position lift cylinder to vehicle. Secure lift cylinder to bed with clevis pin and lynch pins and to engine support with cotter pin.
4. Remove plugs and/or caps from hydraulic hoses and cylinder ports. Connect hydraulic hoses to lift cylinder (see Hydraulic Hose and Tube Installation in this chapter).
5. Start the engine, operate at idle speed and raise and lower bed until air is out of hydraulic system.
6. Stop the engine and check oil level in transaxle (see vehicle Operator's Manual). Add Dexron III ATF if necessary.

## Lift Cylinder Service

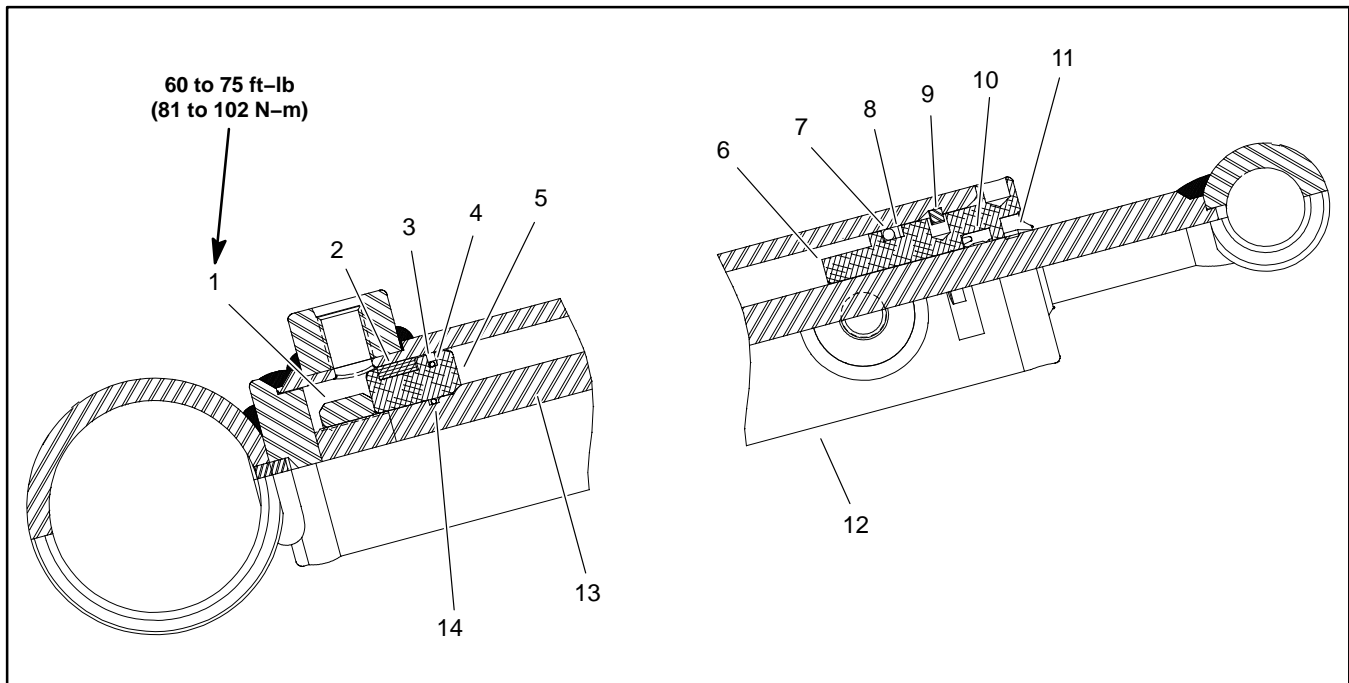

Figure 47

- |              |                   |            |
|--------------|-------------------|------------|
| 1. Lock nut  | 6. Head           | 11. Wiper  |
| 2. Wear ring | 7. O-ring         | 12. Barrel |
| 3. Seal      | 8. Back-up seal   | 13. Shaft  |
| 4. O-ring    | 9. Retaining ring | 14. O-ring |
| 5. Piston    | 10. Seal          |            |

### Disassembly (Fig. 47)

1. Pump oil out of cylinder into a drain pan by slowly moving piston back and forth.
2. Before disassembling cylinder, plug ports, wash exterior with cleaning solvent and dry thoroughly.

**IMPORTANT: Prevent damage when clamping the cylinder's barrel into a vise; clamp on the clevis only. Do not close vise on barrel.**

3. Mount lift cylinder in a vise equipped with soft jaws by clamping on the barrel clevis.
4. Remove retaining ring that secures head in barrel.

A. Use a spanner wrench to rotate head clockwise until the edge of the retaining ring appears in the barrel opening.

B. Insert a screwdriver under the beveled edge of the retaining ring to start the retaining ring through the opening.

C. Rotate the head counter-clockwise to remove retaining ring from barrel and head.

5. Extract shaft with head and piston by carefully twisting and pulling on the shaft.

**IMPORTANT: When securing shaft in vise, clamp on shaft clevis only. Do not clamp vise jaws against the shaft surface.**

6. Mount shaft securely in a vise by clamping on the clevis of the shaft. Remove lock nut and piston from the shaft. Slide head from the shaft.

7. Remove piston seal, O-rings and wear ring from the piston. Remove O-ring, back-up seal, seal and wiper from the head.

### Inspection

1. Wash parts in clean solvent. Dry parts with compressed air. Do not wipe parts dry with paper towels or cloth. Lint in the hydraulic system will cause damage.
2. Carefully inspect internal surface of barrel for damage (deep scratches, out-of-round, etc.).
3. Inspect shaft and piston for evidence of excessive scoring, pitting or wear.
4. Replace lift cylinder if internal components are found to be worn or damaged.

### Assembly (Fig. 47)

1. Make sure all parts are clean before assembly.
2. Coat new O-rings, piston seal, wear ring, shaft seal, back-up ring and dust seal with clean Dexron III ATF.
  - A. Install piston seal, O-rings and wear ring to the piston.
  - B. Install O-ring, back-up seal, seal and wiper to the head.

**IMPORTANT: When securing shaft in vise, clamp on shaft clevis only. Do not clamp vise jaws against the shaft surface.**

3. Mount shaft securely in a vise equipped with soft jaws by clamping on the shaft clevis.
  - A. Coat shaft with clean Dexron III ATF.
  - B. Slide head and piston onto the shaft.
  - C. Secure piston to shaft with lock nut. Torque lock nut from **60 to 75 ft-lb (81 to 102 N-m)**.

4. Lubricate head and piston with clean Dexron III ATF. Slide shaft assembly carefully into cylinder barrel.

**IMPORTANT: Prevent damage when clamping the cylinder's barrel into a vise; clamp on the clevis only. Do not close vise on barrel.**

5. Mount lift cylinder in a vise equipped with soft jaws by clamping on the barrel clevis.
6. Secure head in barrel with retaining ring.
  - A. Align retaining ring hole in the head with the access slot in the barrel.
  - B. Insert the retaining ring hook into the hole and rotate head clockwise until the retaining ring is completely pulled into the barrel and the ring ends are covered.
  - C. Apply silicone sealer to tube access slot.

## Hydraulic Manifold (High Flow Hydraulics Kit)

### Removal (Fig. 48)

1. Park vehicle on a level surface, raise and support bed (if installed), shut engine off and engage the parking brake. Remove key from the ignition switch.
2. Read the General Precautions for Removing and Installing Hydraulic System Components at the beginning of the Service and Repairs section of this chapter.



## CAUTION

Before performing any service or repair on hydraulic system components, relieve system pressure to avoid injury from pressurized hydraulic oil. Stop the engine, remove key from the ignition switch, rotate the steering wheel in both directions, lower or support the bed and operate other hydraulic accessories.

3. Label and disconnect hydraulic hoses and tubes from hydraulic manifold. Install caps or plugs in hoses, tubes and fittings to prevent contamination and leakage of hydraulic oil.
4. Remove manifold from vehicle.

5. If hydraulic fittings are to be removed from manifold, mark fitting orientation to allow correct assembly. Remove fittings from manifold and discard O-rings.

### Valve Cartridge Service (Fig. 49)

1. Make sure the entire outer surface of the manifold is clean before removing the valve.
2. Remove nut securing solenoid coil to the cartridge valve. Carefully slide solenoid off the valve.

**IMPORTANT: Use care when handling the valve cartridge. Slight bending or distortion of the stem tube can cause binding and malfunction.**

3. Remove cartridge valve with a deep socket wrench. Note correct location for O-rings, sealing rings and backup rings on valve. Remove and discard seal components.
4. Visually inspect the port in the manifold for damage to the sealing surfaces, damaged threads or contamination.

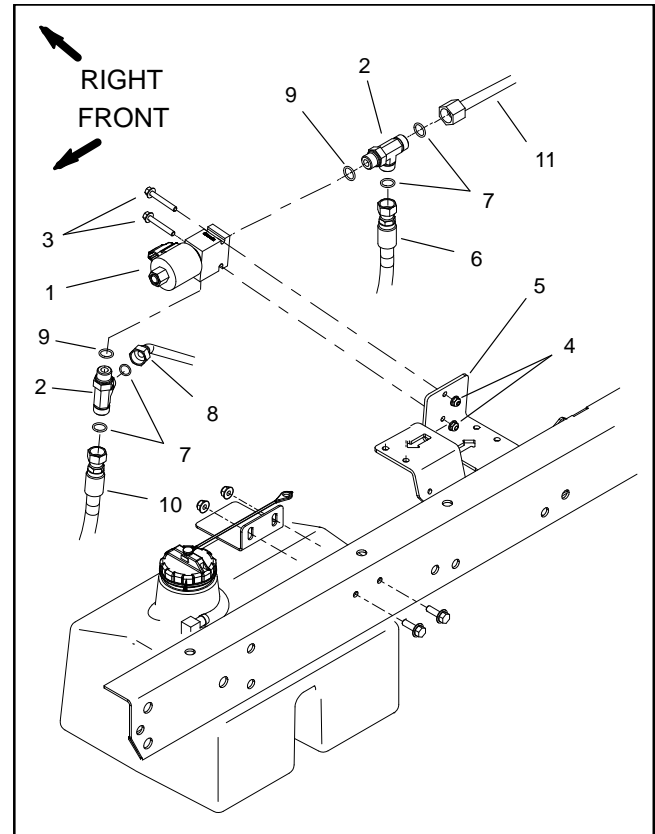

Figure 48

- |                          |                    |
|--------------------------|--------------------|
| 1. Hydraulic manifold    | 7. O-ring          |
| 2. Hydraulic tee fitting | 8. Hydraulic tube  |
| 3. Flange head screw     | 9. O-ring          |
| 4. Flange nut            | 10. Hydraulic hose |
| 5. Frame bracket         | 11. Hydraulic tube |
| 6. Hydraulic hose        |                    |

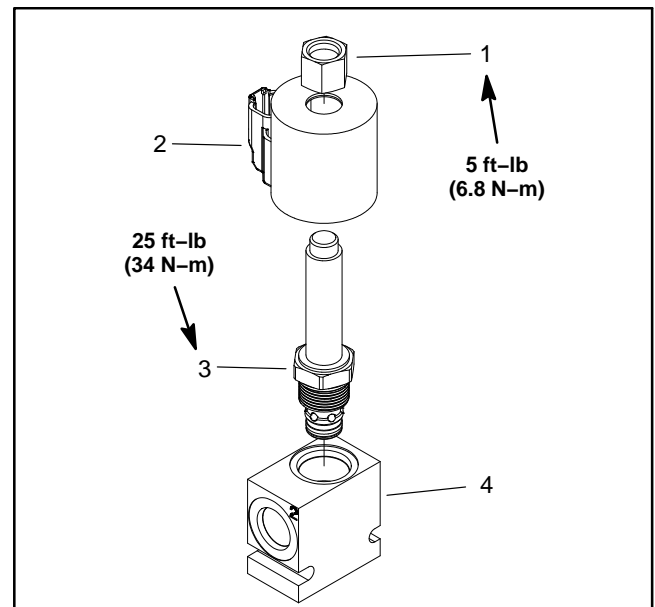

Figure 49

- |                  |                             |
|------------------|-----------------------------|
| 1. Nut           | 3. Solenoid cartridge valve |
| 2. Solenoid coil | 4. Manifold body            |

5. Visually inspect cartridge valve for damaged sealing surfaces and contamination.

A. Contamination may cause valves to stick or hang up. Contamination can become lodged in small valve orifices or seal areas causing malfunction.

B. If valve sealing surfaces appear pitted or damaged, the hydraulic system may be overheating or there may be water in the system.



6. Clean cartridge valve using clean mineral spirits. Submerge valve in clean mineral spirits to flush out contamination. Particles as fine as talcum powder can affect the operation of high pressure hydraulic valves. If cartridge design allows, use a wood or plastic probe to push the internal spool in and out 20 to 30 times to flush out contamination. Be extremely careful to not damage cartridge. Use compressed air for cleaning.

7. Reinstall the cartridge valve:

A. Lubricate new seal kit components with clean hydraulic oil and install on valve. The O-rings, sealing rings and backup rings must be arranged properly on the cartridge valve for proper operation and sealing.

**IMPORTANT: Use care when handling the cartridge valve. Slight bending or distortion of the stem tube can cause binding and malfunction.**

B. Thread cartridge valve carefully into manifold port. The valve should go in easily without binding.

C. Using a deep socket, torque cartridge valve **25 ft-lb (34 N-m)**.

D. Slide solenoid coil onto the cartridge valve. Install nut and torque **5 ft-lb (6.8 N-m)**. Over-tightening may damage the solenoid or cause the valve to malfunction.

8. If problems still exist, remove valve and clean again or replace valve.

### Installation (Fig. 48)

1. If fittings were removed from manifold, lubricate and place new O-rings onto fittings. Install fittings into manifold openings using marks made during the removal process to properly orientate fittings. Tighten fittings (see Hydraulic Fitting Installation in the General Information section of this chapter).

2. Install manifold to vehicle.

3. Replace O-rings on hydraulic hoses and fittings. Remove caps and plugs from hoses and fittings. Connect hydraulic hoses to manifold (see Hydraulic Hose and Tube Installation in the General Information section).

4. Check oil level in reservoir. Add correct oil if necessary.

This page is intentionally blank.



## Table of Contents

SPECIFICATIONS ..... 2  
GENERAL INFORMATION ..... 3  
    Operator's Manual ..... 3  
SERVICE and REPAIRS ..... 4  
    Constant Velocity (CV) Axle Assembly ..... 4  
    Inspect CV Boot and Test CV Joint ..... 6  
    Differential Driveshaft ..... 8  
    Driveshaft Cross and Bearing Service ..... 10  
    Front Differential ..... 12  
    Front Differential Service ..... 14  
HILLIARD FRONT DRIVE DIFFERENTIAL PARTS and SERVICE MANUAL

# Specifications

Item	Description
Differential Oil Capacity	8.5 fl oz (250 ml)
Differential Oil Type	Mobil 424 Hydraulic Oil



## General Information

The “Automatic on Demand” four wheel drive feature on 4WD Workman vehicles does not require operator activation. The front differential on 4WD Workman vehicles is an electro–mechanically activated bi–directional overrunning clutch system. The front differential is engaged whenever the ignition switch is in the ON position and the clutch is engaged.

No power is delivered to the front wheels until the rear wheels begin to lose traction. When the rear wheels lose traction, the dual bi–directional clutches in the front differential sense the rear wheels slipping and engage the front wheel drive instantaneously to deliver power to the front wheels. The four wheel drive system

continues to deliver power to the front wheels until the rear wheels have enough traction to move the vehicle without slipping. Once this occurs, the system stops delivering power to the front wheels and the handling characteristics become similar to that of a two wheel drive vehicle. The four wheel drive system functions in both forward and reverse. When the front wheels are turned, the rear wheels will slip slightly more before power is delivered to the front wheels.

When the clutch is disengaged (clutch pedal pushed in), the vehicle differential relay is energized which removes electrical current to the front differential to disengage the differential (no power delivered to front wheels).

---

### Operator’s Manual

The vehicle Operator’s Manual provides information regarding the operation, general maintenance and maintenance intervals for your Workman vehicle. Refer to the Operator’s Manual for additional information when servicing the vehicle.

# Service and Repairs

## Constant Velocity (CV) Axle Assembly

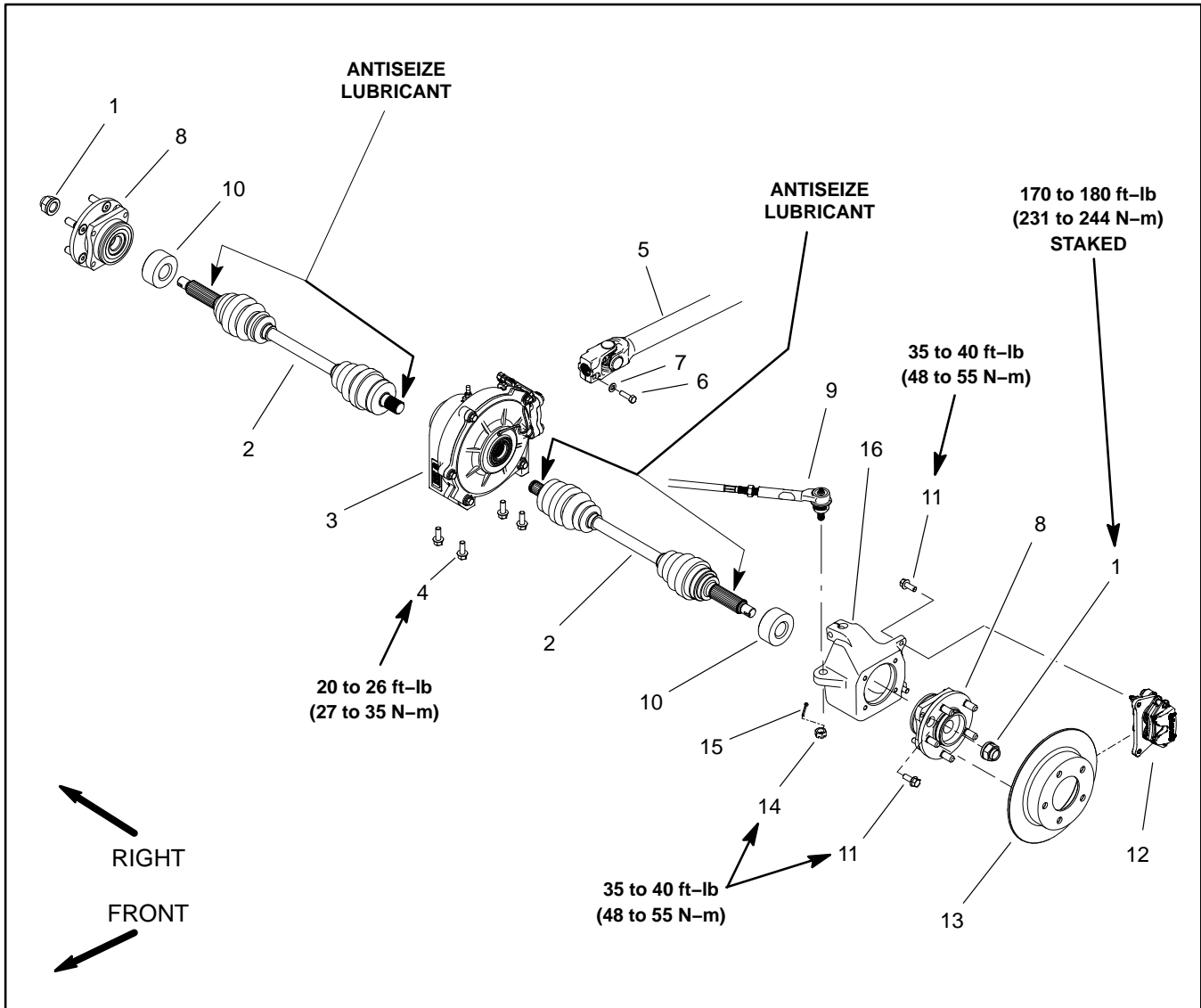

Figure 1

- |                          |                       |                              |
|--------------------------|-----------------------|------------------------------|
| 1. Spindle nut           | 7. Flat washer        | 12. Brake caliper (LH shown) |
| 2. CV axle assembly      | 8. Wheel hub assembly | 13. Brake rotor              |
| 3. Differential assembly | 9. Tie rod assembly   | 14. Slotted hex nut          |
| 4. Flange head screw (4) | 10. Axle spacer       | 15. Cotter pin               |
| 5. Driveshaft            | 11. Flange head screw | 16. Knuckle (LH shown)       |
| 6. Cap screw             |                       |                              |

### Disassembly (Fig. 1)

1. Park vehicle on a level surface, shut engine off, remove key from ignition switch and apply parking brake.

2. For Constant velocity (CV) axle to be removed, remove wheel assembly, brake caliper and brake rotor (see Brake System Disassembly in Chapter 7 – Chassis in this manual).

3. Remove spindle nut from the threaded shaft of the CV axle. Discard spindle nut.

**NOTE:** Spindle nuts are staked (deformed) to the CV axle during assembly. Clear away the deformed area of the nut before removing the nut from the axle or damage to the axle threads will occur.

4. Using wheel hub hole to access flange head screws, remove screws that secure wheel hub to knuckle. Slide wheel hub assembly from CV axle.

5. Remove axle spacer from CV axle.

**IMPORTANT: Make sure to not damage the oil seal on the differential with the pry bars when removing the CV axle.**

6. Use two small pry bars (180 degrees apart) to leverage the CV axle out of the differential. Use even pressure on both pry bars (Fig. 2).

7. Pull CV axle through opening in knuckle and remove from vehicle.

**Assembly (Fig. 1)**

**NOTE:** The inner end of the CV axle has a retaining ring to keep axle engaged in differential. The outer end of the axle has threads for the spindle nut.

1. Apply antiseize lubricant to splines on inner end of CV axle.

2. Insert inner end of CV axle through knuckle and into the differential. Press axle into differential until a snap is heard.

**IMPORTANT: After CV axle installation into differential, pull outward on CV axle as close as possible to the differential to make sure that the axle is properly secured into the differential.**

3. Place wheel spacer onto CV axle.

4. Apply antiseize lubricant to splines on outer end of CV axle.

5. Slide wheel hub onto CV axle. Loosely install four (4) flange head screws to locate wheel hub to knuckle. Do not fully tighten screws.

6. Install new spindle nut onto CV axle. Torque spindle nut from **170 to 180 ft-lb (231 to 244 N-m)**. After tightening nut, stake nut extension into slot in axle.

7. Fully tighten flange head screws to secure wheel hub to knuckle. Torque screws from **35 to 40 ft-lb (48 to 55 N-m)**.

8. Install brake rotor, brake caliper and wheel assembly (see Brake System Assembly in Chapter 7 – Chassis in this manual).

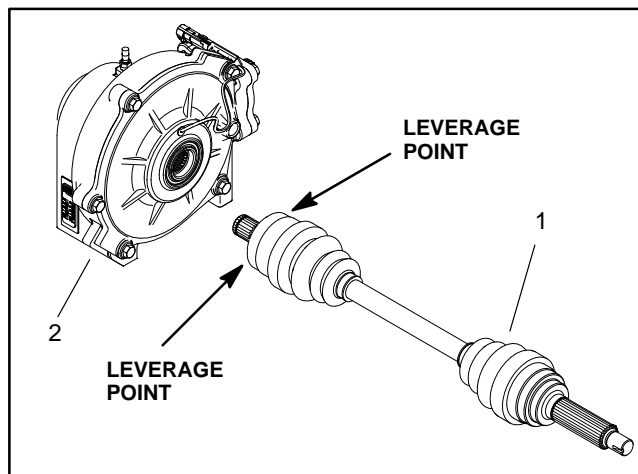

Figure 2

- 1. CV axle (LH shown)
- 2. Differential assembly



## WARNING

**Failure to maintain proper wheel lug nut torque could result in failure or loss of wheel and may result in personal injury. Torque wheel lug nuts from 80 to 90 ft-lb (109 to 122 N-m).**

9. Make sure that wheel lug nuts are properly tightened.

## Inspect CV Axle Boot and Test CV Axle

### Inspect CV Axle Boot

A torn CV axle boot is the most common cause of CV axle failures.

**NOTE:** A worn and noisy CV axle joint with the boot in good condition and filled with grease is not uncommon. Potholes, curb contact or collision damage can damage bearing components and initiate worn conditions.

1. Look for grease on front suspension components, inner tire sidewall or fender to indicate a possible torn boot. Inspect boot for cracks, holes, tears or loose clamps. Dirty grease within the boot may indicate damage to the CV axle joint.

2. If the boot is cracked or torn, has any holes or has loose clamps, remove CV axle (see CV Axle Assembly in this section) and replace boot.

### Test CV Axle

1. Test drive vehicle on a smooth surface to verify CV axle joint problem.

2. Accelerate or back-up vehicle slowly with the front wheels turned. Listen for snapping or clicking noise at the wheel, then drive straight ahead.

A. If the noise remains constant, the wheel bearing is the likely problem and, if so, the wheel hub assembly must be replaced.

B. If the noise gets louder when turning, the outboard CV axle joint is likely worn. A badly worn joint will snap or click when driving straight ahead, however the noise will increase when accelerating or backing up into a turn.

3. Accelerate vehicle quickly and straight ahead. Vibration or shudder often indicates a worn or sticking inboard CV axle joint.

4. Accelerate vehicle at an angle over a ramp or up a hill. A clunking noise indicates a worn inboard CV axle joint.

5. If any CV axle components are worn or damaged, the CV axle assembly must be replaced.

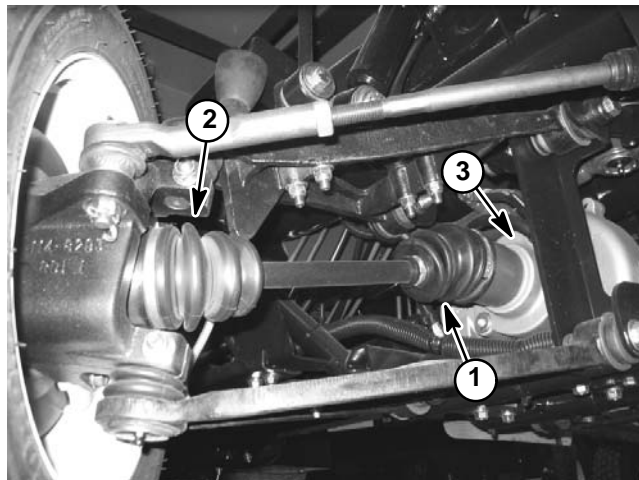

Figure 3

- 1. Inboard boot
- 2. Outboard boot
- 3. Differential assembly

This page is intentionally blank.

# Differential Driveshaft

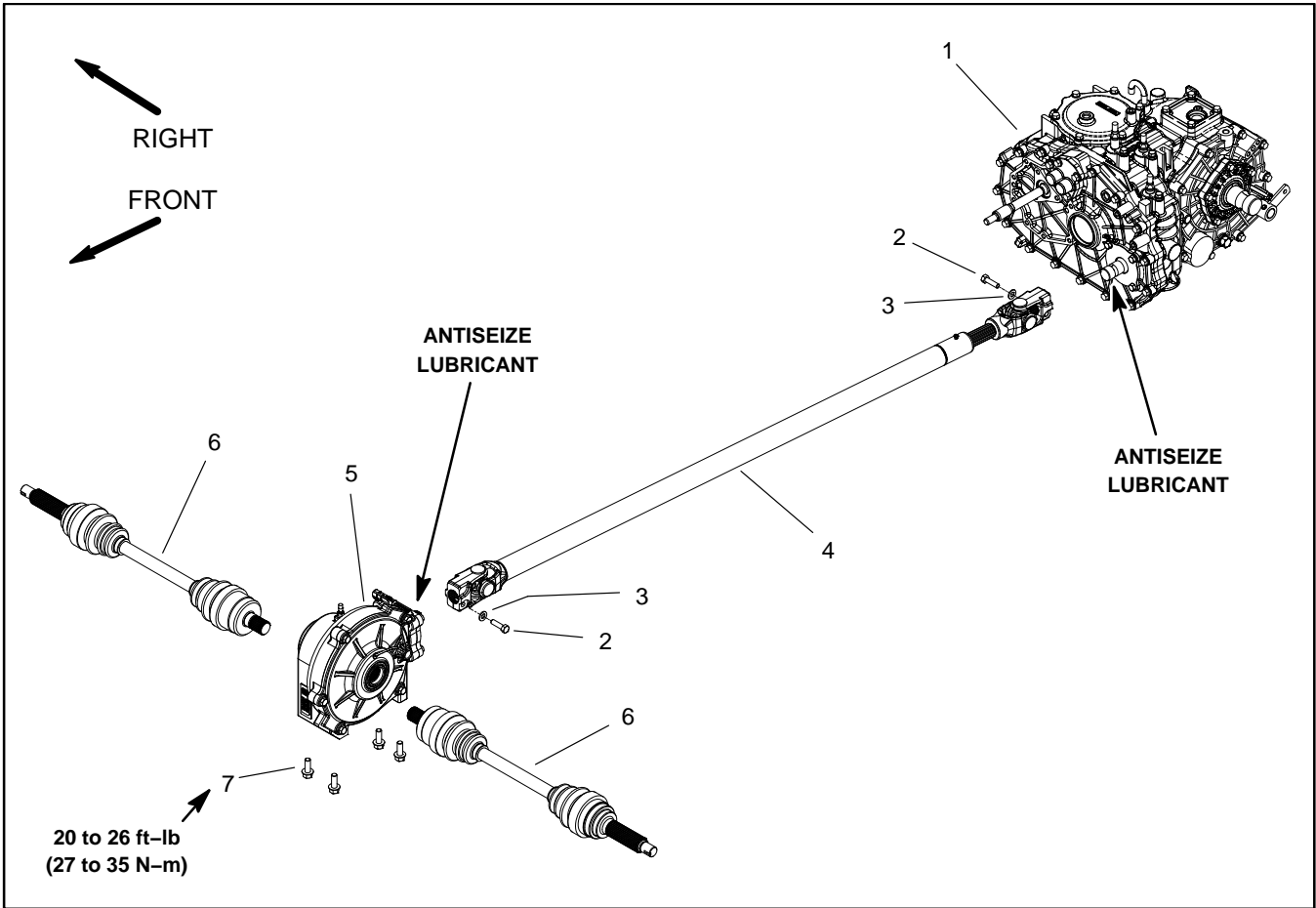

Figure 4

- 1. Transaxle
- 2. Cap screw
- 3. Flat washer
- 4. Driveshaft
- 5. Differential assembly
- 6. CV axle assembly
- 7. Flange head screw (4)

### Removal (Fig. 4)

1. Park vehicle on a level surface, shut engine off, remove key from ignition switch and apply parking brake.
2. Remove cap screw and flat washer that secure the driveshaft yokes to differential input shaft and transaxle output shaft.

	<h2>WARNING</h2>
<p><b>Support driveshaft to prevent it from dropping and causing personal injury when removing.</b></p>	

3. Support driveshaft to prevent it from falling.
4. Slide driveshaft yokes from the differential input shaft and the transaxle output shaft.
5. Lower rear of driveshaft and remove shaft from vehicle.

### Installation (Fig. 4)

1. Apply antiseize lubricant to differential input shaft and transaxle output shaft.
2. Position driveshaft to vehicle frame, differential assembly and transaxle.
3. Slide driveshaft yokes onto differential input shaft and transaxle output shaft
4. Secure driveshaft yokes with cap screw and flat washer.
5. Lubricate differential driveshaft grease fittings.

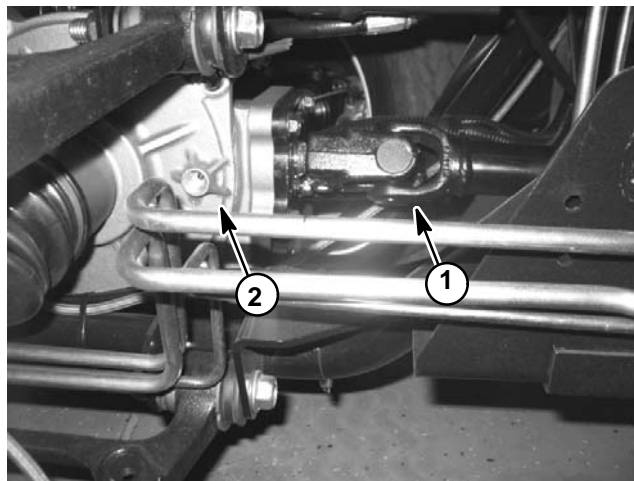

Figure 5

1. Driveshaft flange yoke      2. Differential assembly

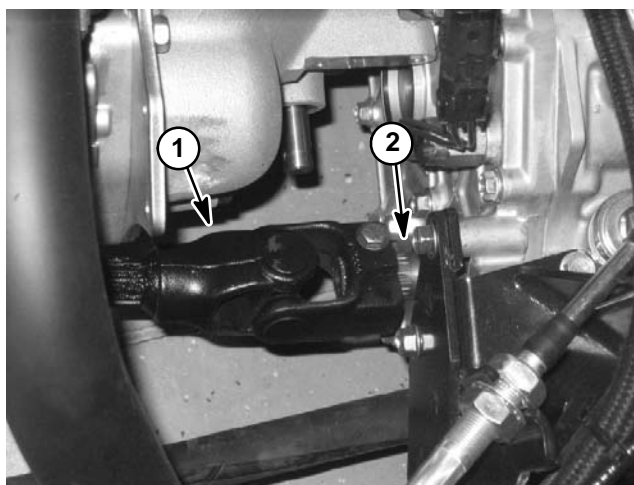

Figure 6

1. Driveshaft slip yoke      2. Transaxle shaft

## Driveshaft Cross and Bearing Service

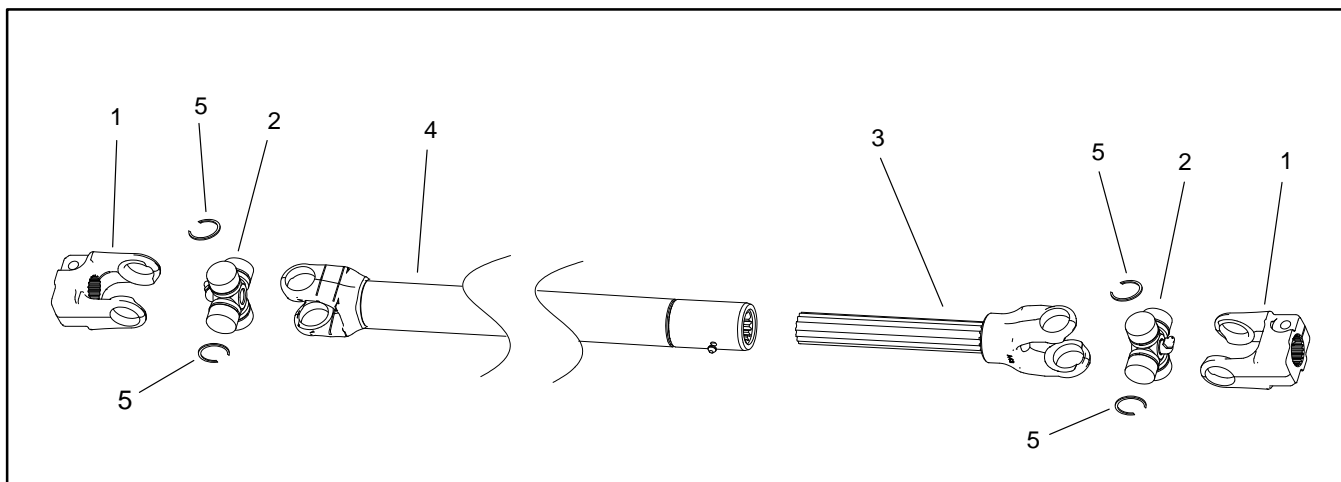

Figure 7

- 1. Yoke
- 2. Cross and bearing kit

- 3. Yoke and shaft
- 4. Yoke and tube

- 5. Snap ring

### Disassembly (Fig. 7)

1. Remove driveshaft from vehicle (see Differential Driveshaft Removal in this section).

**IMPORTANT: When placing yoke in vise, clamp lightly on the solid part of the yoke to prevent yoke damage. Also, the use of a vise with soft jaws is recommended.**

2. Lightly clamp yoke in vise. Use two (2) screwdrivers to carefully remove snap rings that secure bearings at the inside of each yoke. Remove yoke from vise.

**IMPORTANT: Yokes must be supported when removing and installing bearings to prevent damage.**

3. Use a press to remove cross and bearings from yokes:

- A. Place a small socket against one bearing and a large socket against the yoke on the opposite side.
- B. While supporting the large socket, apply pressure on small socket to partially push the opposite bearing into the large socket.
- C. Remove yoke from press, grasp partially removed bearing and tap on yoke to completely remove the bearing.
- D. Repeat process for remaining bearings.
- E. Thoroughly clean and inspect all components.

### Assembly (Fig. 7)

1. To install new cross and bearings:

A. Apply a coating of grease to bearing bores of end yoke and shaft yoke. Also, apply grease to bearings and seal of bearing assembly. Make sure that all bearing rollers are properly seated in bearing cage.

B. Press one bearing partially into yoke.

**IMPORTANT: Take care when installing cross into bearing to avoid damaging bearing seal.**

C. Carefully insert cross into bearing and yoke.

D. Hold cross in alignment and press bearing in until it hits the yoke.

E. Carefully place second bearing into yoke bore and onto cross shaft. Press bearing into yoke.

F. Install snap rings to bearings to secure bearings in place.

G. Repeat procedure for other yoke.

H. Grease cross until grease comes out of all four (4) bearing cups.

2. Make sure that assembled joint moves without binding. Slight binding can usually be eliminated by lightly rapping the yoke lugs with a soft faced hammer. If binding continues, disassemble joint to identify source of binding.

3. Install driveshaft to vehicle (see Differential Driveshaft Installation in this section).



This page is intentionally blank.

# Front Differential

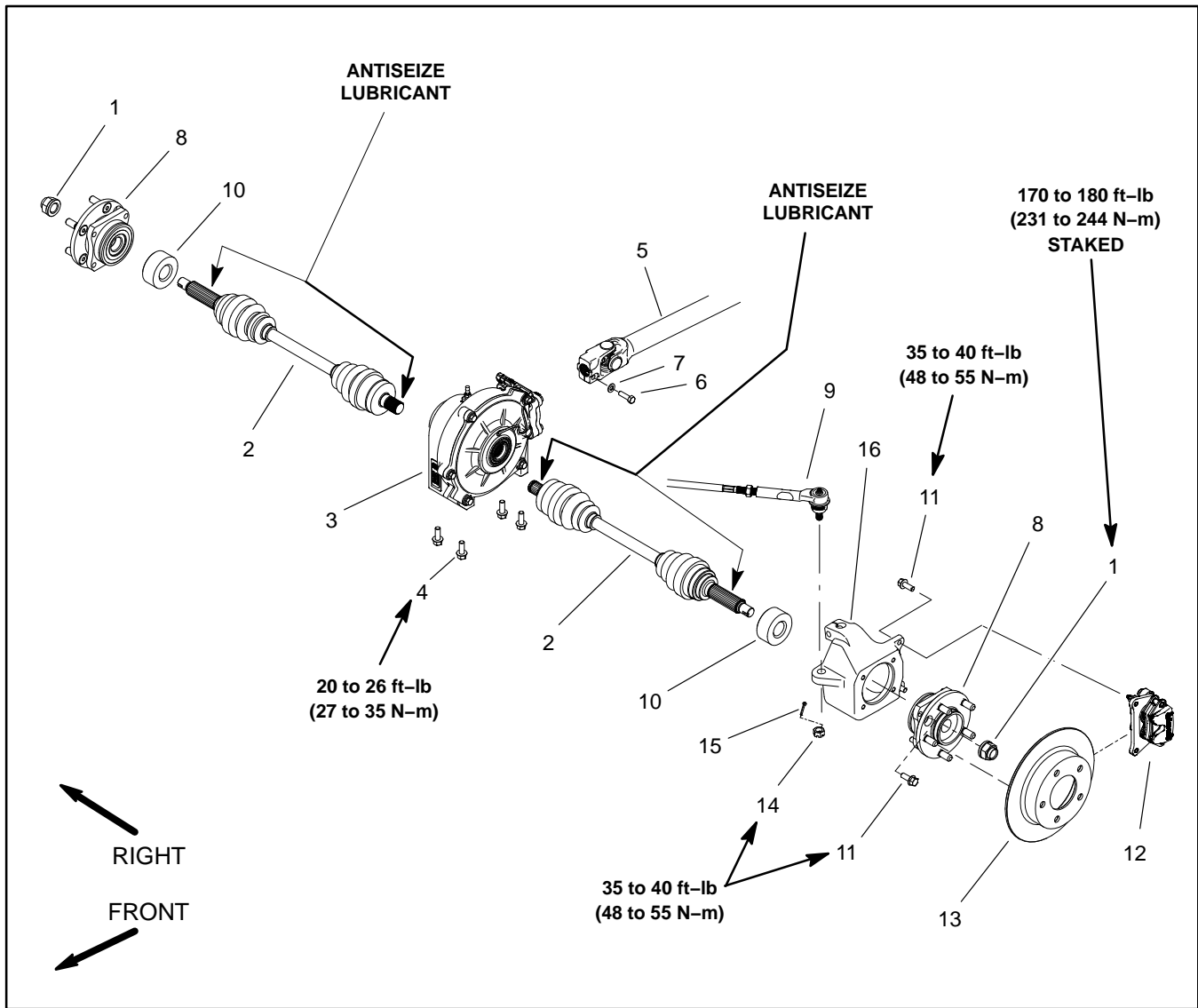

Figure 8

- |                          |                       |                              |
|--------------------------|-----------------------|------------------------------|
| 1. Spindle nut           | 7. Flat washer        | 12. Brake caliper (LH shown) |
| 2. CV axle assembly      | 8. Wheel hub assembly | 13. Brake rotor              |
| 3. Differential assembly | 9. Tie rod assembly   | 14. Slotted hex nut          |
| 4. Flange head screw (4) | 10. Axle spacer       | 15. Cotter pin               |
| 5. Driveshaft            | 11. Flange head screw | 16. Knuckle (LH shown)       |
| 6. Cap screw             |                       |                              |

### Removal (Fig. 8)

1. Park vehicle on a level surface, shut engine off, remove key from ignition switch and apply parking brake. Block rear wheels to prevent the vehicle from moving unexpectedly.
2. Drain differential oil into a suitable container by removing the drain plug. Install drain plug after draining.
3. Unplug wire harness connector from differential.
4. Remove both CV axle assemblies from the differential (see CV Axle Assembly Removal in this section).
5. Remove cap screw and flat washer that secure driveshaft yoke to the differential input shaft. Separate differential driveshaft yoke from the differential input shaft (see Differential Driveshaft Removal in this section).



## CAUTION

**Support differential during removal to prevent personal injury from falling and damage to the differential.**

6. Remove four (4) flange head screws that secure the differential to the frame.
7. On right side (passenger side) of vehicle, remove inner two (2) flange head screws and flange nuts that secure control arm tower to upper control arm (Fig. 9). Removal of these two (2) fasteners allows clearance for differential removal. To prevent unexpected front suspension movement, **do not** loosen outer flange head screws and flange nuts.

**IMPORTANT: Make sure to not damage brake lines, electrical harness, control cables or other parts while removing the differential.**

8. Tip differential toward left side (driver side) of vehicle. Remove differential assembly toward the right side (passenger side) of the vehicle.

### Installation (Fig. 8)

**IMPORTANT: Make sure to not damage brake lines, electrical harness, control cables or other parts while installing the differential to the vehicle.**

1. Position differential to the vehicle frame.

2. Secure differential to the frame with four (4) flange head screws.
3. Install and tighten inner two (2) flange head screws and flange nuts that secure control arm tower to upper control arm (Fig. 9).
4. Apply antiseize lubricant to input shaft of differential. Slide driveshaft yoke onto differential input shaft.
5. Secure driveshaft yoke to the differential with cap screw and flat washer (see Differential Driveshaft Installation in this section).
6. Install both CV axles to the differential (see CV Axle Assembly Installation in this section).
7. Connect wire harness connector to differential.
8. Make sure differential drain plug is installed properly. Fill differential with oil.

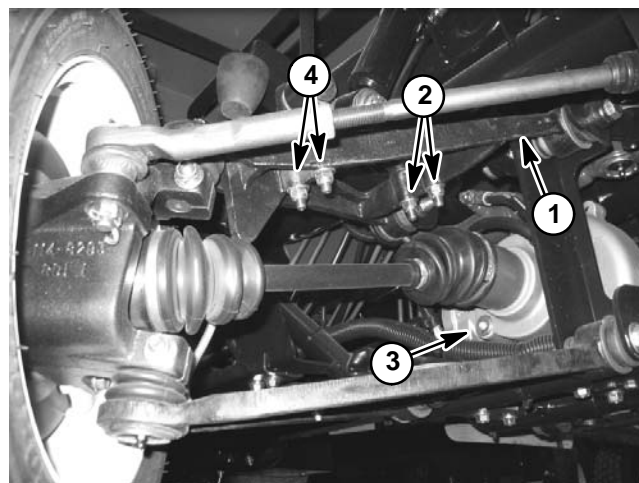

Figure 9

- |                         |                        |
|-------------------------|------------------------|
| 1. Upper RH control arm | 3. Differential        |
| 2. Inner screw and nut  | 4. Outer screw and nut |

# Front Differential Service

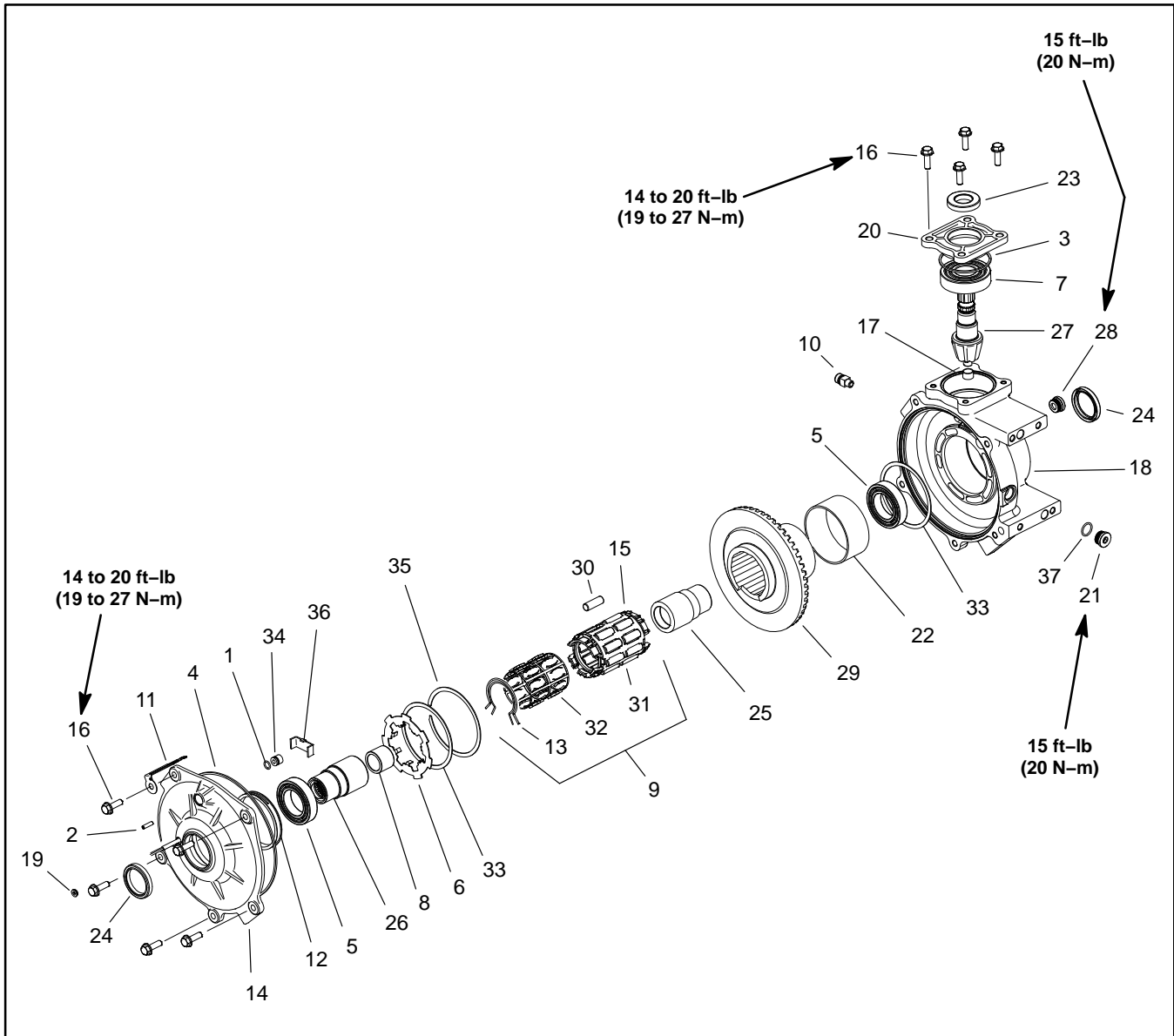

Figure 10

- |                         |                           |                             |
|-------------------------|---------------------------|-----------------------------|
| 1. O-ring               | 14. Cover plate           | 26. Male output hub         |
| 2. Set screw            | 15. End ring (2)          | 27. Pinion shaft            |
| 3. O-ring               | 16. Flange head screw (9) | 28. Fill plug               |
| 4. O-ring               | 17. Bearing               | 29. Ring gear               |
| 5. Bearing (2)          | 18. Gear case             | 30. Roller (18)             |
| 6. Armature plate       | 19. Grommet               | 31. Roller cage             |
| 7. Bearing              | 20. Input cover           | 32. Spring                  |
| 8. Bushing              | 21. Drain plug            | 33. Gear spacer (2)         |
| 9. Roller cage assembly | 22. Bushing               | 34. Thrust button           |
| 10. Vent                | 23. Oil seal              | 35. Internal retaining ring |
| 11. Plug clip           | 24. Oil seal (2)          | 36. Thrust bearing          |
| 12. Coil                | 25. Female output hub     | 37. O-ring                  |
| 13. Torsion spring      |                           |                             |

### Front Differential Disassembly

1. Make sure that the oil is drained from the differential assembly.
2. Remove the four (4) flange head screws from the input cover. Remove the cover.

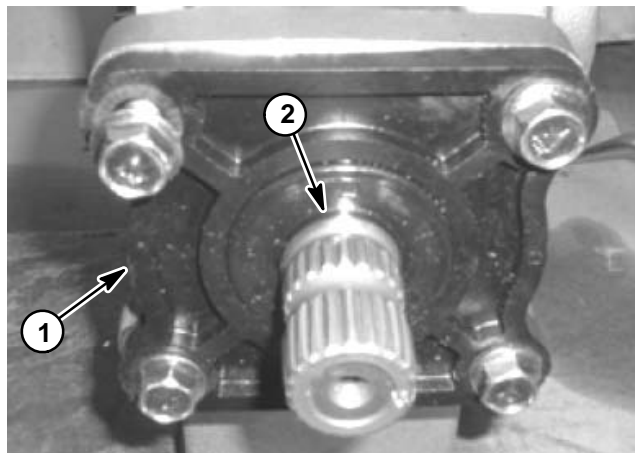

Figure 11

1. Input cover
2. Pinion shaft

3. Remove the pinion shaft from housing by pulling it out of the gear case by hand.

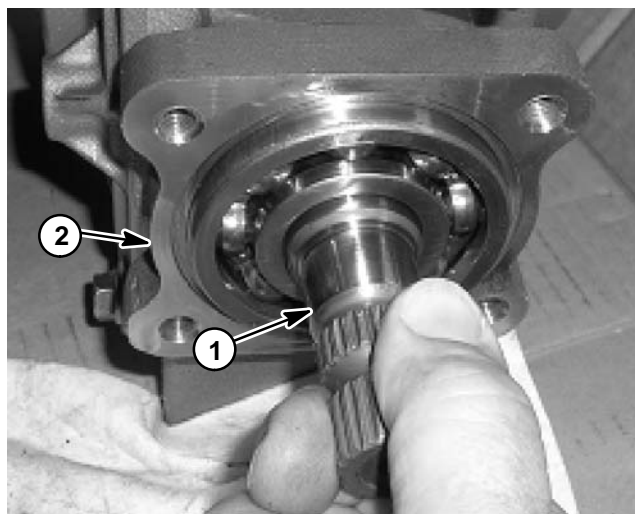

Figure 12

1. Pinion shaft
2. Gear case

4. Inspect the inner pinion bushing in the gear case. If the bushing is excessively worn, the gear case must be replaced. The bushing is not serviced separately.

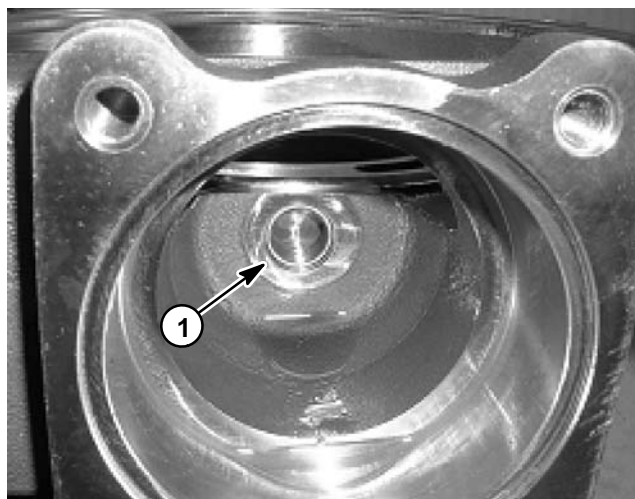

Figure 13

1. Pinion bushing

5. Place the differential assembly on workbench with the cover plate facing up.

6. Remove the five (5) flange head screws that secure cover plate to gear case. Note location of plug clip for assembly purposes. Carefully remove the cover plate from the gear case by lifting straight up.

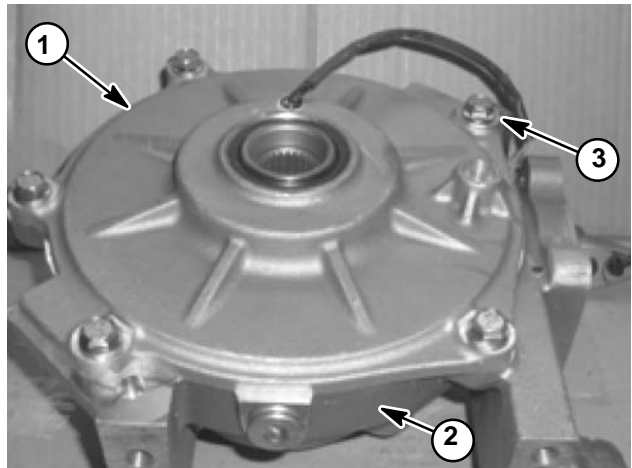

Figure 14

- 1. Cover plate
- 2. Gear case
- 3. Plug clip

7. Remove the thrust bearing from the cover plate and inspect for wear. Replace the thrust bearing if the red coating is worn completely off the bearing surface. The thrust bearing is used to set the backlash of the ring gear and pinion (see Front Differential Assembly in this section for backlash adjustment procedure).

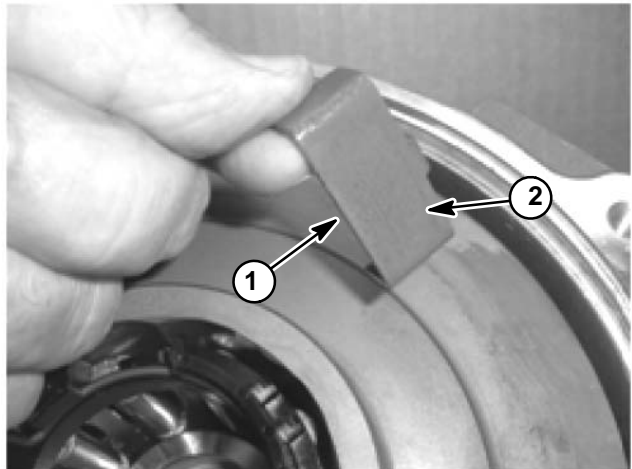

Figure 15

- 1. Thrust bearing
- 2. Thrust surface

8. Lift the roller cage assembly from the center of the ring gear.

**NOTE:** the rollers are loose in the cage and may fall out when removed.

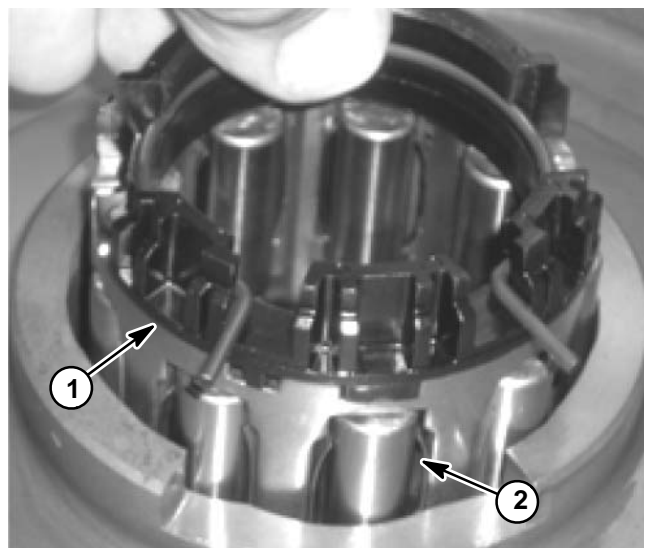

Figure 16

- 1. Roller cage assembly
- 2. Roller

9. Carefully lift the ring gear out of the gear case. Inspect ring gear teeth for any damage or abnormal wear.

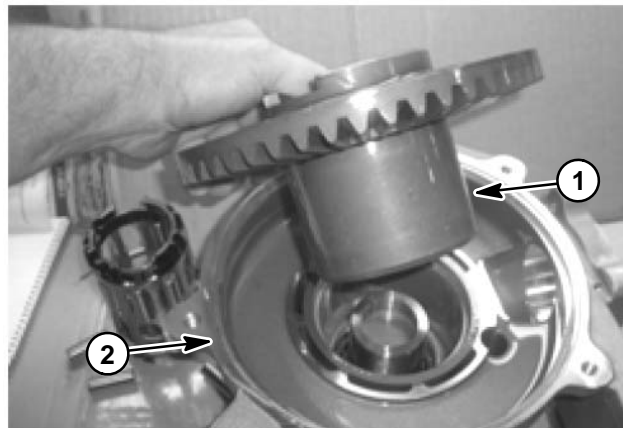

Figure 17

- 1. Ring gear
- 2. Gear case

10. Remove the gear spacer from between the gear case and the ring gear.

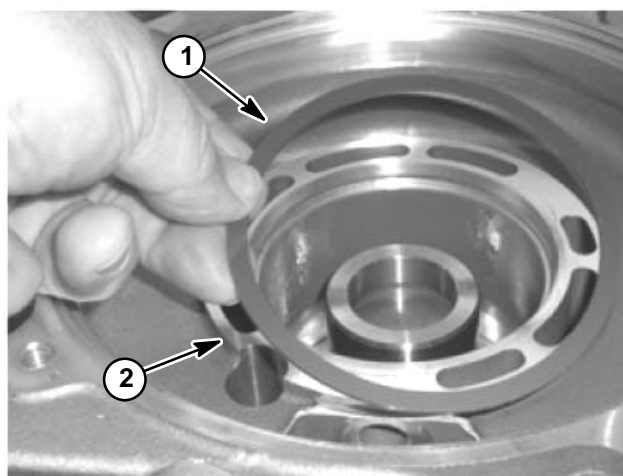

Figure 18

- 1. Gear spacer
- 2. Gear case

**IMPORTANT:** When removing female output hub from gear case, be careful to not damage the seal in the gear case. The seal cannot be serviced separately.

11. Turn the gear case over. Using a hammer and a suitable drift, carefully remove the female output hub and bearing by driving it in toward the center of the gear case. The bearing has a slight interference fit to the bore of the gear case. Take care to not damage the oil seal in the gear case during hub removal.

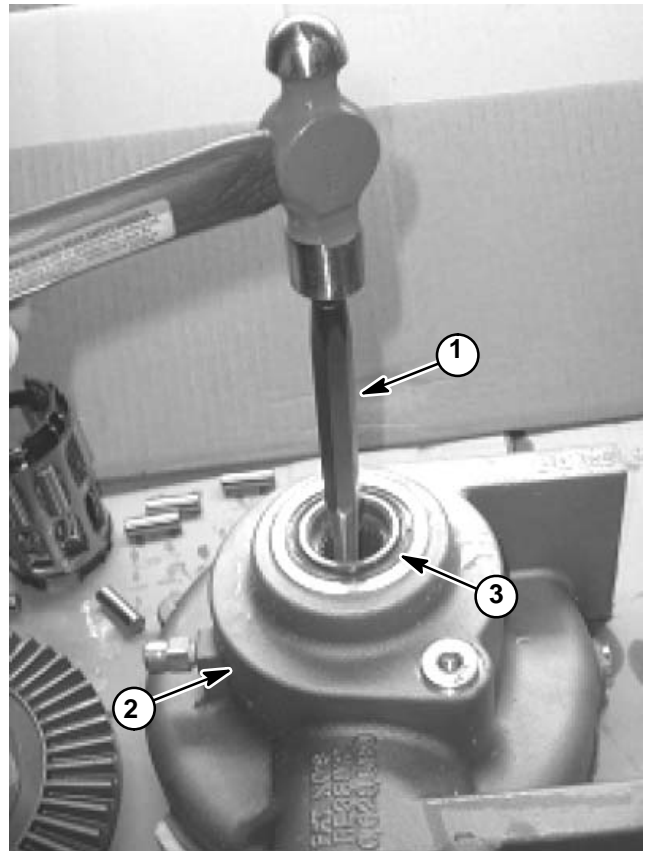

Figure 19

- 1. Drift
- 2. Gear case
- 3. Oil seal

12. Place the cover plate on the workbench with the male output hub facing up.

13. Using a screwdriver, remove the internal retaining ring from the cover plate.

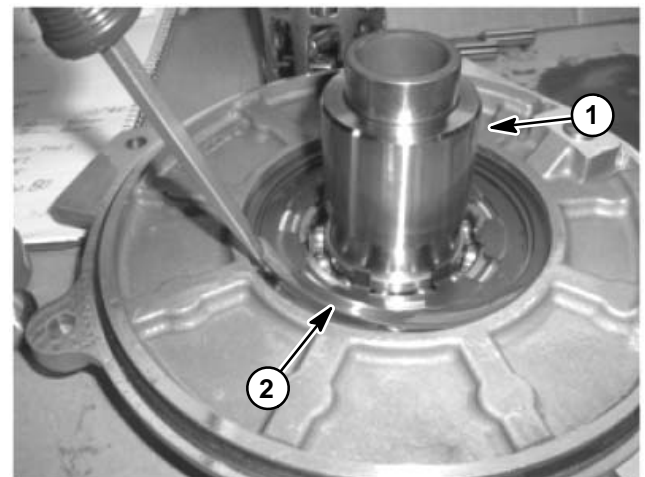

Figure 20

- 1. Male output hub
- 2. Retaining ring



14. Remove the gear spacer from the cover plate.

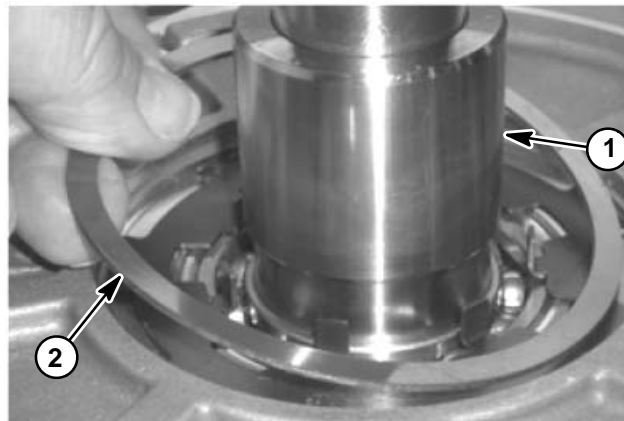

Figure 21

- 1. Male output hub
- 2. Gear spacer

15. Remove the armature plate from the cover plate.

**IMPORTANT:** When removing male output hub from cover plate, be careful to not damage the seal in the cover plate. The seal cannot be serviced separately.

16. Turn the cover plate over and place it on blocking or in a vise. Using a hammer and suitable punch, carefully remove the male output hub and bearing from the cover plate by driving the output hub down. The bearing has a slight interference fit to the bore of the cover plate. Be careful to not damage the seal in the cover plate.

17. Discard the removed output hub assemblies. Clean and inspect all removed parts.

**NOTE:** For additional front differential information, see the Hilliard Front Drive Differential Parts and Service Manual at the end of this chapter.

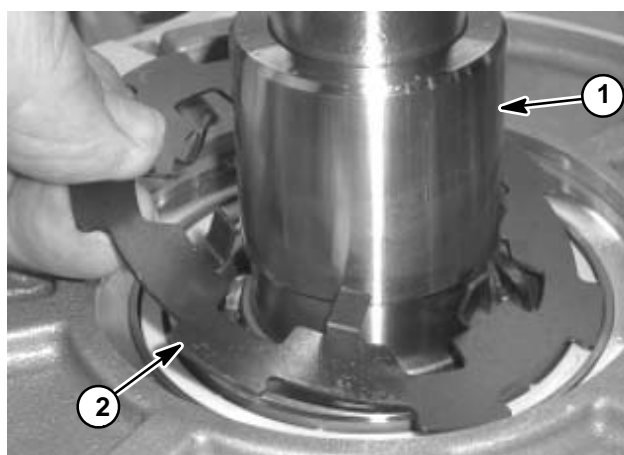

Figure 22

- 1. Male output hub
- 2. Armature plate

## Front Differential Assembly

1. Be sure that all parts are clean and free of any dirt or debris. Make sure that all residual oil has been removed from differential components.

2. Check the condition of the square sectioned O-ring located on the cover plate. Make sure that it is clean and free of any cuts or nicks.

**IMPORTANT:** When installing male output hub assembly into cover plate, be careful to not damage the seal in the cover plate. The seal cannot be serviced separately.

**NOTE:** The male output hub has an extended bushing.

3. Press the new male output hub/bearing assembly into the cover plate assembly. The bearing has a slight interference fit to the bore, so it should not take much force to press in. Take care to not damage the seal in the cover plate during installation of the output hub assembly.

4. Set the armature plate onto the coil located in the cover plate. The internal tangs of the armature plate should face up as shown.

5. Place the gear spacer on top of the armature plate and secure with retaining ring. Make sure that retaining ring is fully seated into groove in cover plate.

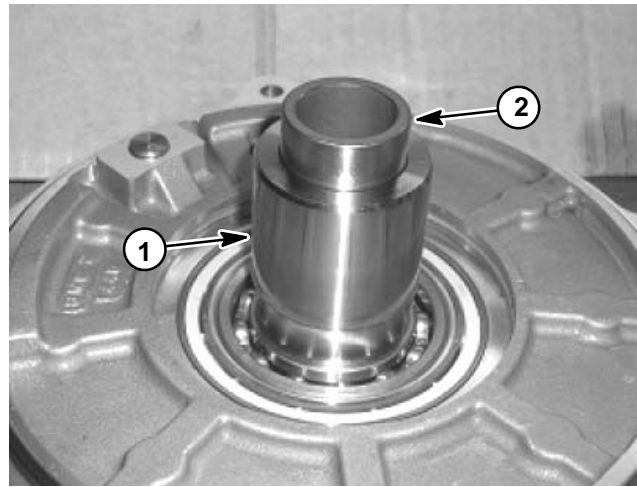

Figure 23

1. Male output hub                      2. Extended bushing

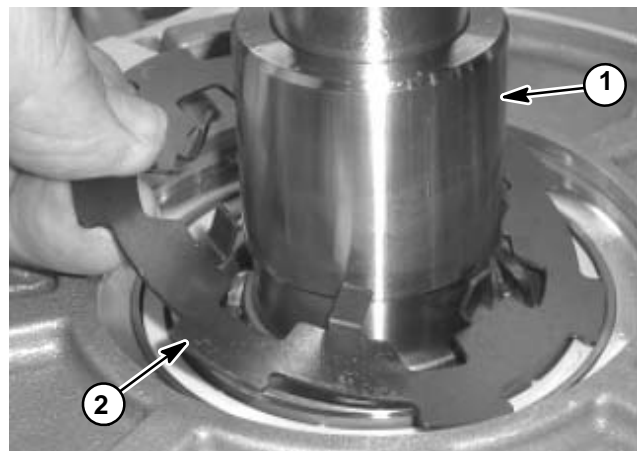

Figure 24

1. Male output hub                      2. Armature plate

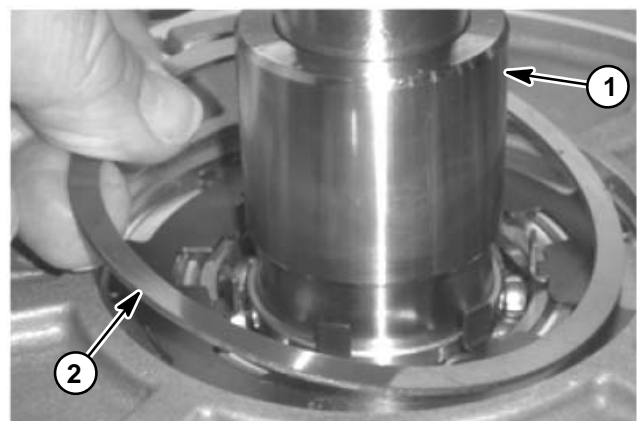

Figure 25

1. Male output hub                      2. Gear spacer

**IMPORTANT:** When installing female output hub assembly into gear case, be careful to not damage the seal in the gear case. The seal cannot be serviced separately.

6. Press the new female output hub/bearing assembly into the gear case from the inside. The bearing has a slight interference fit to the bore, so it should not take much force to press in. Take care to not damage the seal during installation of the output hub assembly.

7. Place the gear spacer to the gear case and then install the ring gear into the gear case.

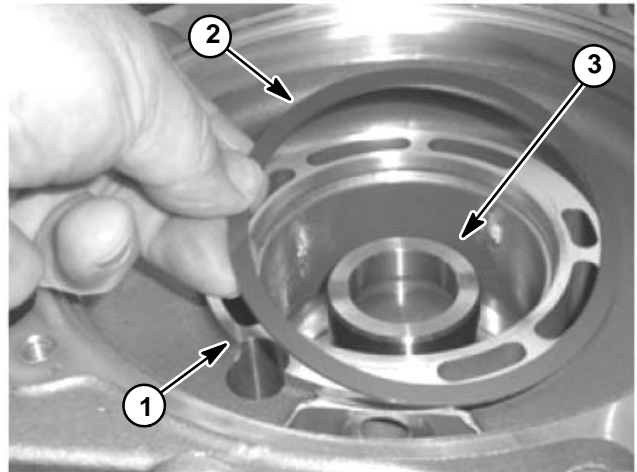

Figure 26

- 1. Gear case
- 2. Gear spacer
- 3. Female output hub

8. Set the roller cage on a flat surface with the torsion spring end facing up. Install nine (9) rollers into the slots on the bottom row of the cage. If needed, use grease or petroleum jelly to help hold the rollers in place.

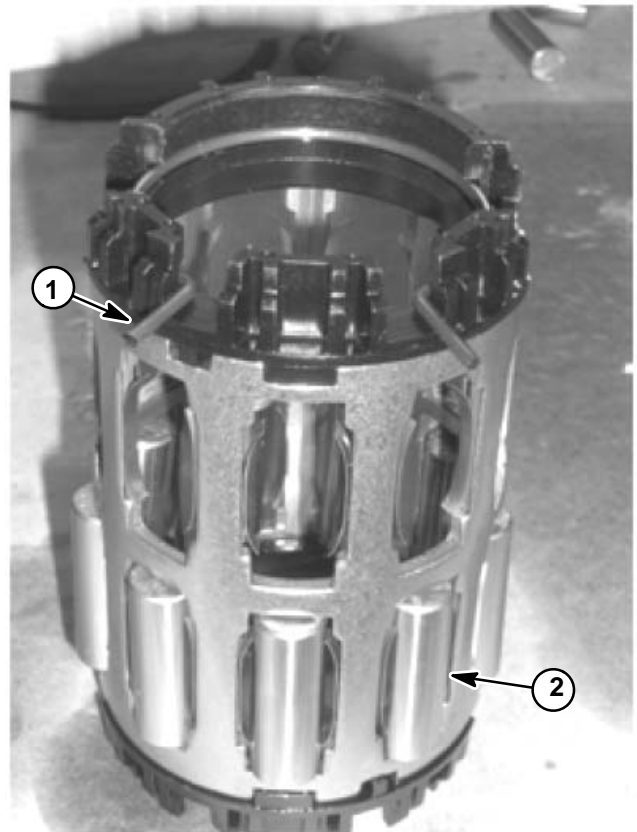

Figure 27

- 1. Torsion spring
- 2. Lower roller

9. Align torsion spring on roller cage with the slot in the ring gear and then carefully lower the cage assembly into the ring gear bore. The torsion spring must align and fit into the notch cut into the ring gear.

10. Install remaining nine (9) rollers into the top row of the roller cage assembly. Place the rollers in the roller cage slots and press them out toward the ring gear bore.

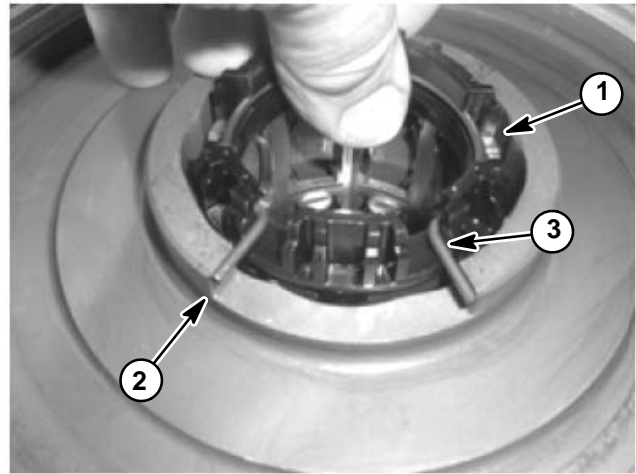

Figure 28

- 1. Roller cage assembly
- 2. Ring gear notch
- 3. Torsion spring

11. Install the thrust bearing onto the thrust button in the cover plate. Make sure that the tang on the side of the thrust bearing is located toward the outer edge of the cover plate. Use grease or petroleum jelly on the back side of the thrust plate to keep the bearing in position while assembling the cover plate assembly to the gear case.

**IMPORTANT: When installing the cover plate, make sure that the tangs on the armature plate are properly aligned into the slots on the roller cage. Improper assembly can cause damage to the armature plate and will prevent 4WD from engaging.**

12. Place the cover plate onto the gear case assembly. Make sure to line up the tangs on the armature so they will insert into the mating slots on the roller cage. Also, make sure to align the cover plate bolt holes with the threaded holes in the gear case.

13. Position plug clip to correct location on cover plate and secure cover plate to gear case with five (5) flange head screws. Torque screws from **14 to 17 ft-lbs (19 to 27 N-m)**.

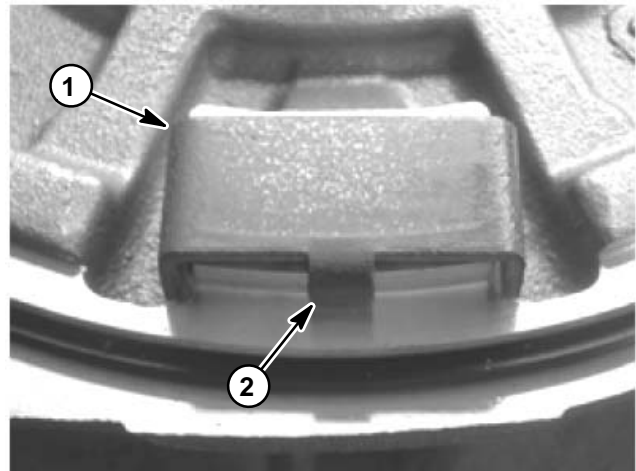

Figure 29

- 1. Thrust bearing
- 2. Bearing tang

14. Install the pinion shaft and then the input cover. Secure cover with four (4) flange head screws. Torque screws from **14 to 17 ft-lbs (19 to 27 N-m)**.

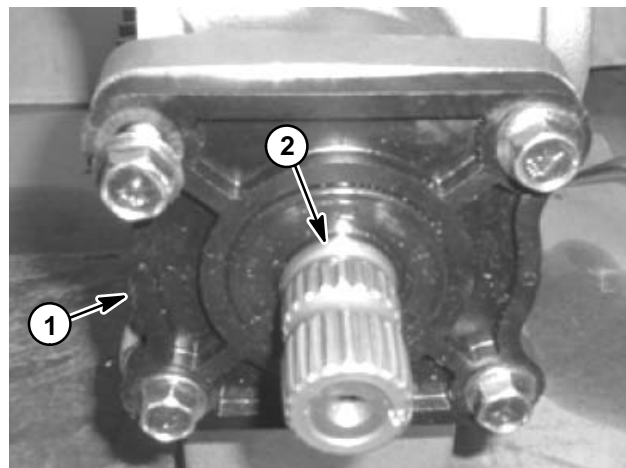

Figure 30

- 1. Input cover
- 2. Pinion shaft

15. Remove the oil fill plug and fill the unit with 8.45 oz. (250 ml.) of Mobil 424 hydraulic oil (or equivalent).

16. Adjust differential gear backlash as follows:

A. Locate backlash adjustment set screw inside round boss on cover plate.

B. Using a 3/32" allen wrench, turn the set screw clockwise until it is snug (do not over-tighten the set screw). At this point, you should not be able to turn the pinion shaft.

C. Slowly turn the set screw counter-clockwise until the pinion shaft can just be turned.

D. Continue to slowly turn the set screw counter-clockwise until the pinion shaft can freely rotate six (6) times (one revolution of the ring gear) without any tight spots. This proper backlash should be achieved after the set screw has been turned counter-clockwise from 1/4 to 1/2 of a turn.

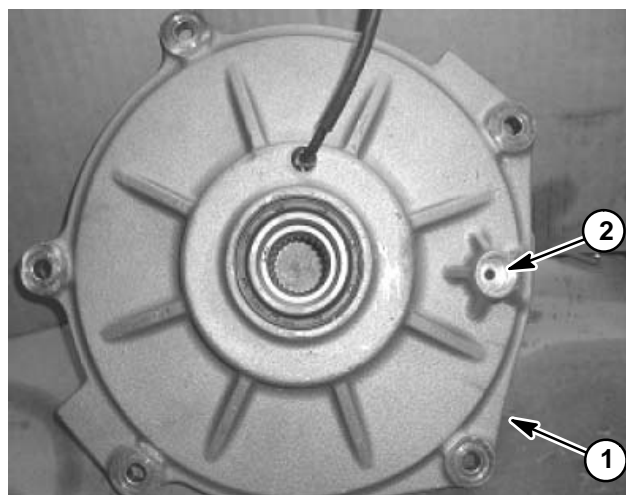

Figure 31

- 1. Cover plate
- 2. Set screw

This page is intentionally blank.



**Table of Contents**

ELECTRICAL DRAWING DESIGNATIONS ..... 2

ELECTRICAL SCHEMATICS

    Workman HD ..... 3

    Workman HDX ..... 4

    Workman HDX- D ..... 5

WIRE HARNESS DRAWINGS

    Front Wire Harness: Workman HD ..... 6

    Rear Wire Harness: Workman HD ..... 8

    Front Wire Harness: Workman HDX ..... 10

    Rear Wire Harness: Workman HDX ..... 12

    Front Wire Harness: Workman HDX- D ..... 14

    Rear Wire Harness: Workman HDX- D ..... 16

    Front Wire Harness:

        Workman HDX- D (Industrial) ..... 18

    Rear Wire Harness:

        Workman HDX- D (Industrial) ..... 20

# Electrical Drawing Designations

The following abbreviations are used for wire harness colors on the electrical schematics and wire harness drawings in this chapter.

<u>ABBREVIATION</u>	<u>COLOR</u>
BK	BLACK
BR or BN	BROWN
BU	BLUE
GN	GREEN
GY	GRAY
OR	ORANGE
PK	PINK
R or RD	RED
T	TAN
VIO	VIOLET
W or WH	WHITE
Y or YE	YELLOW

Numerous harness wires used on Workman HD vehicles include a line with an alternate color. These wires are identified with the wire color and line color with either a / or \_ separating the color abbreviations listed above (e.g. R/BK is a red wire with a black line, OR\_BK is an orange wire with a black line).

**NOTE:** A splice used in a wire harness will be identified on the wire harness diagram by SP. The manufacturing number of the splice is also identified on the wire harness diagram (e.g. SP01 is splice number 1).



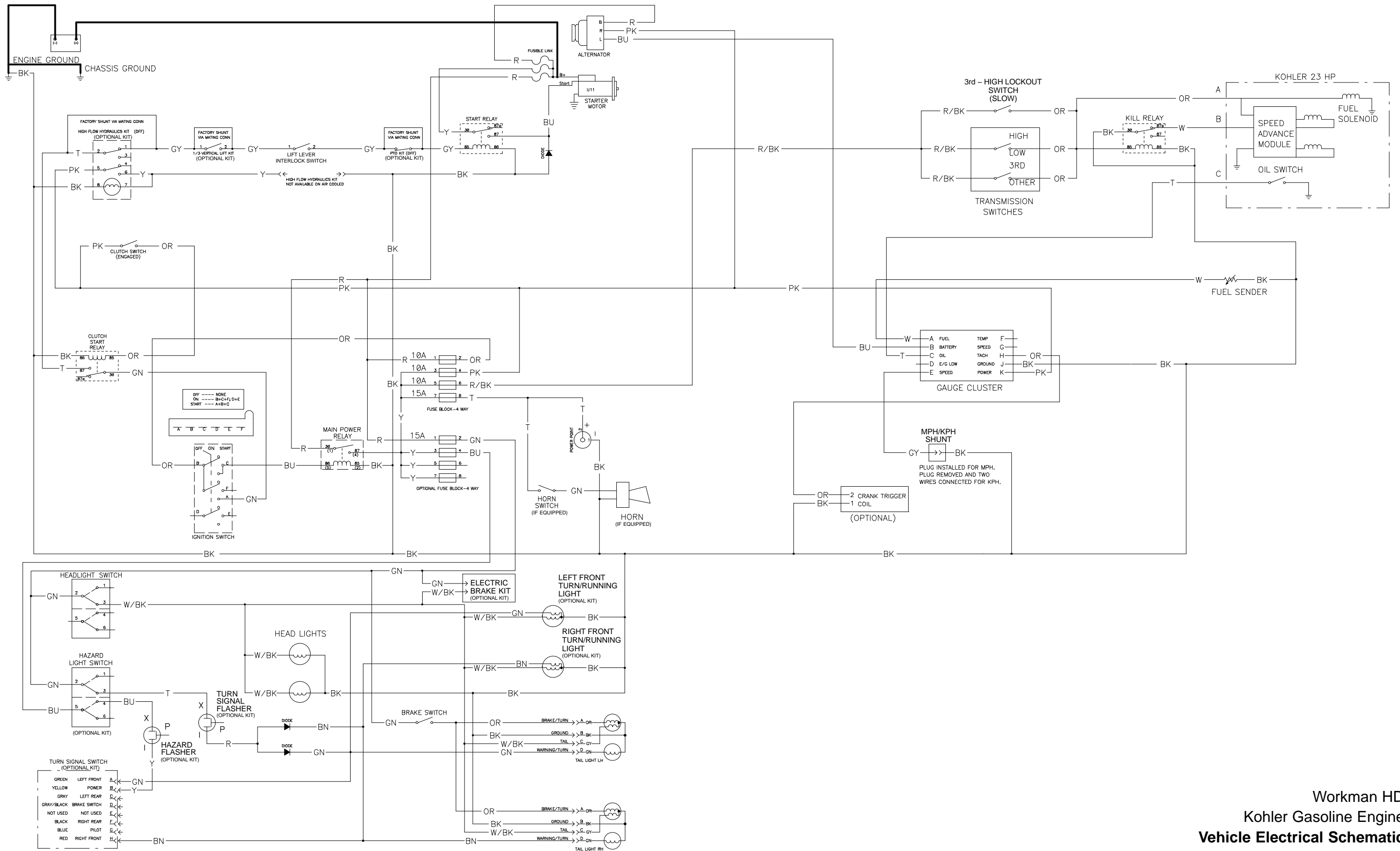

Workman HD  
Kohler Gasoline Engine  
Vehicle Electrical Schematic

All relays and solenoids  
are shown as de-energized.

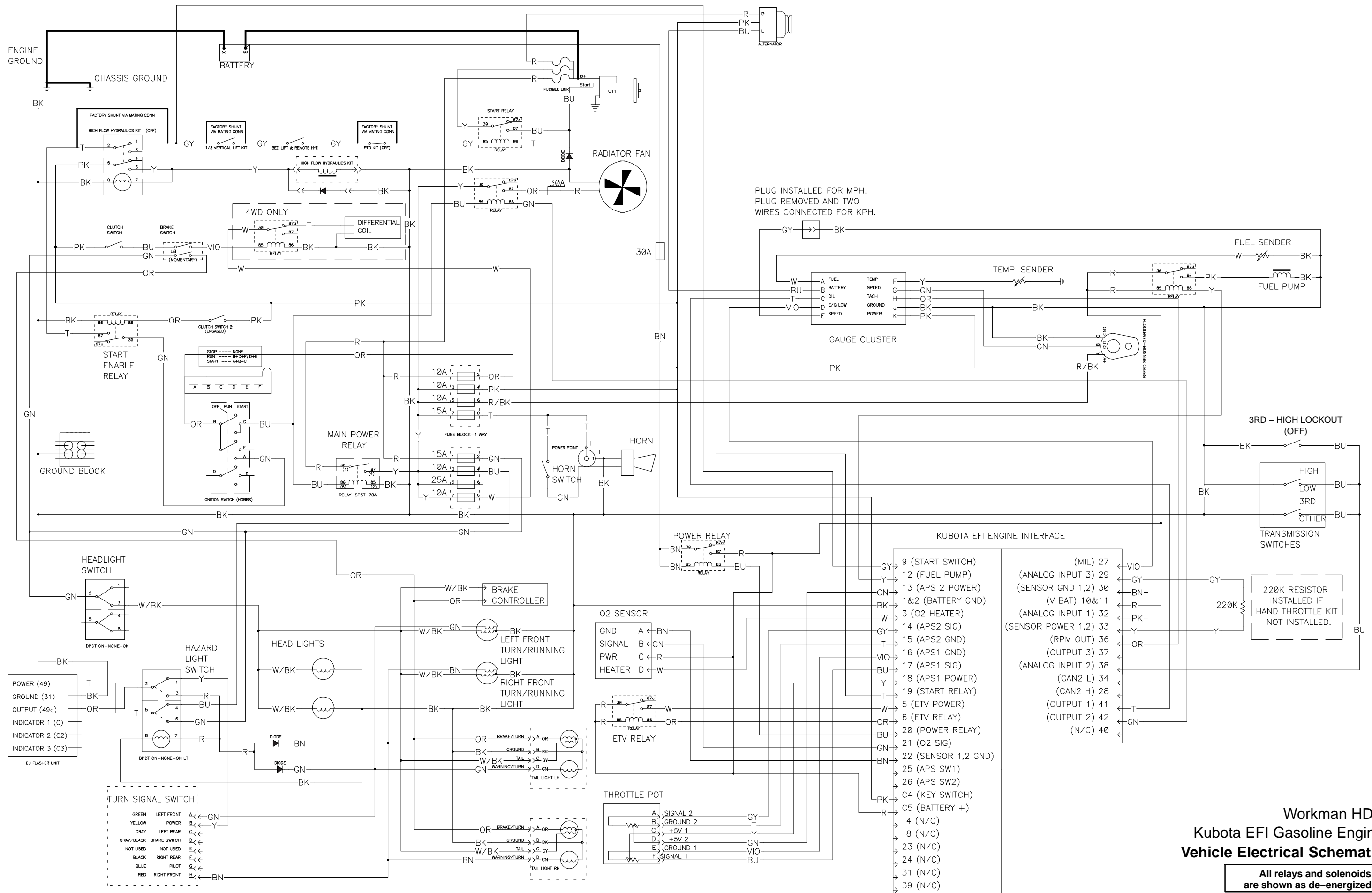

**Workman HDX  
Kubota EFI Gasoline Engine  
Vehicle Electrical Schematic**

**All relays and solenoids  
are shown as de-energized.**



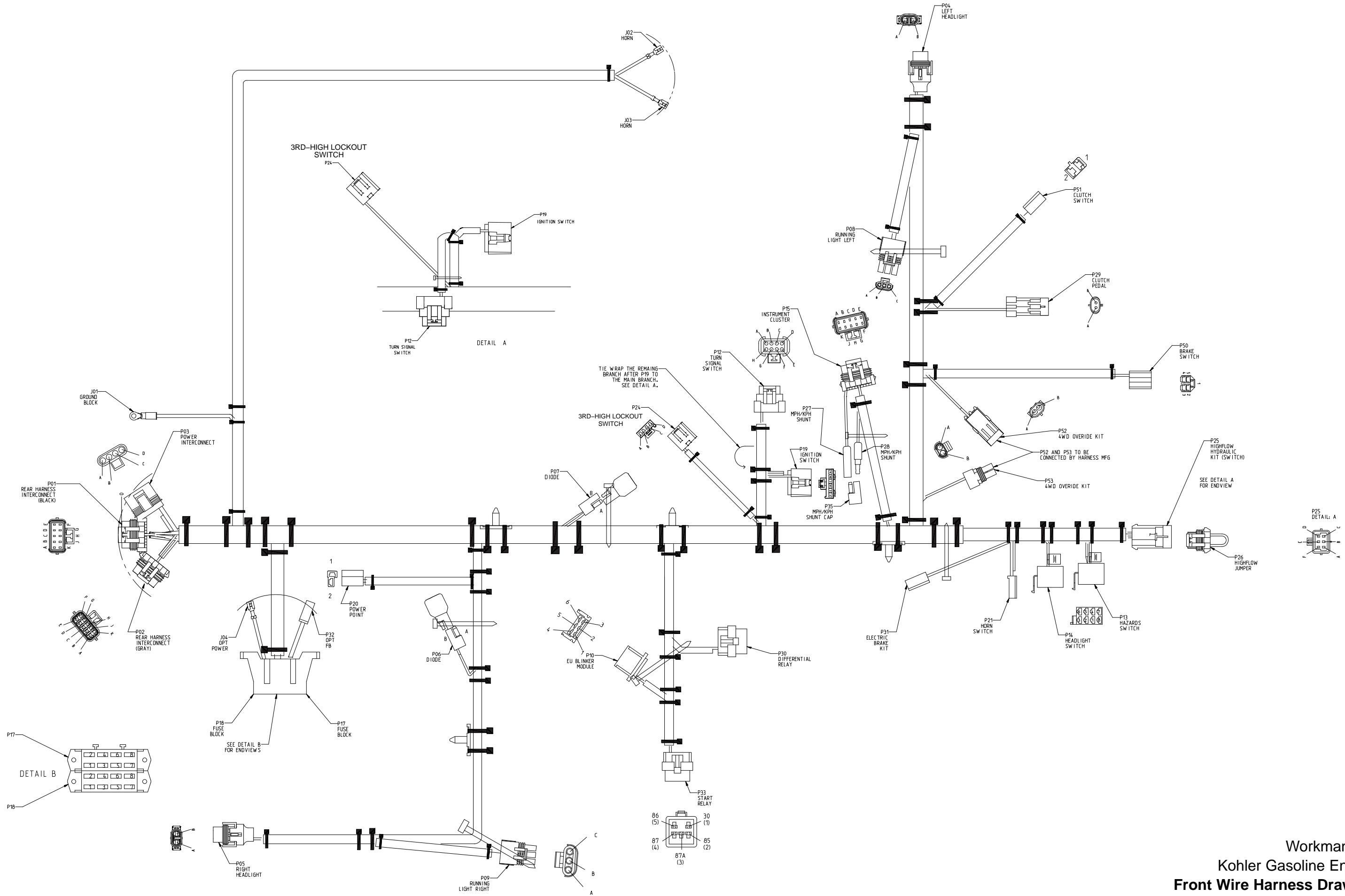

Workman HD  
 Kohler Gasoline Engine  
 Front Wire Harness Drawing

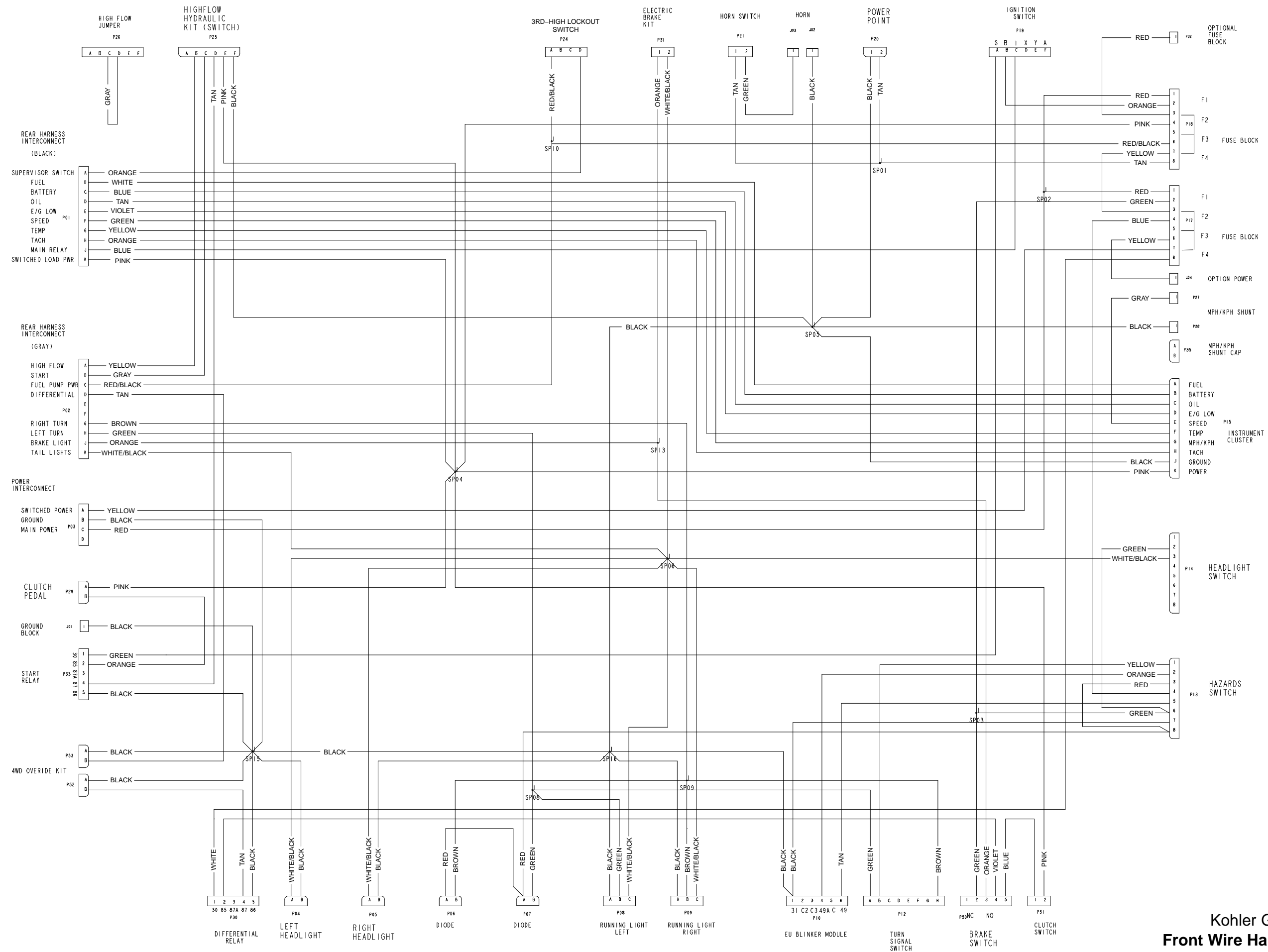

Workman HD  
 Kohler Gasoline Engine  
**Front Wire Harness Diagram**

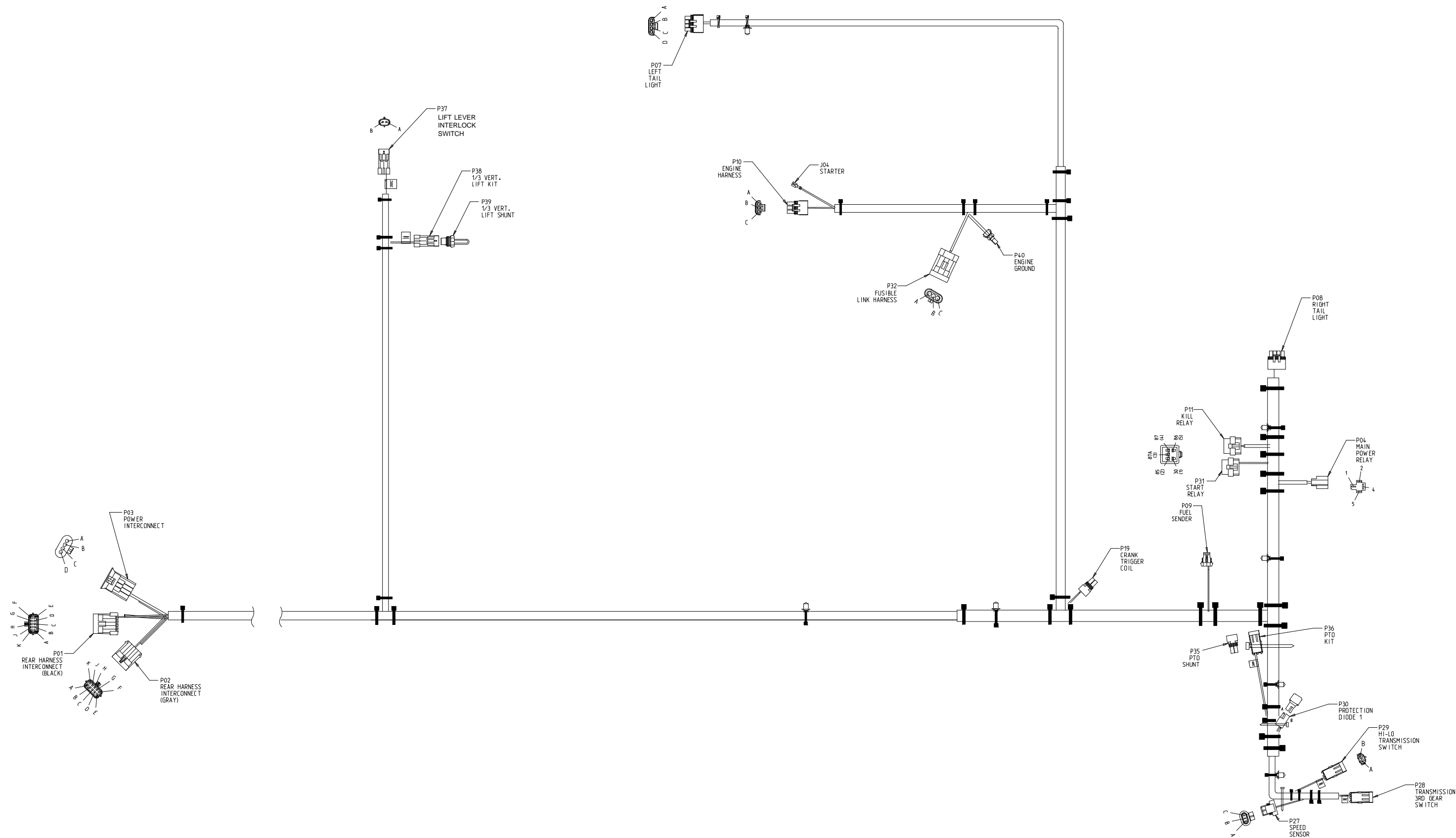

Workman HD  
 Kohler Gasoline Engine  
 Rear Wire Harness Drawing

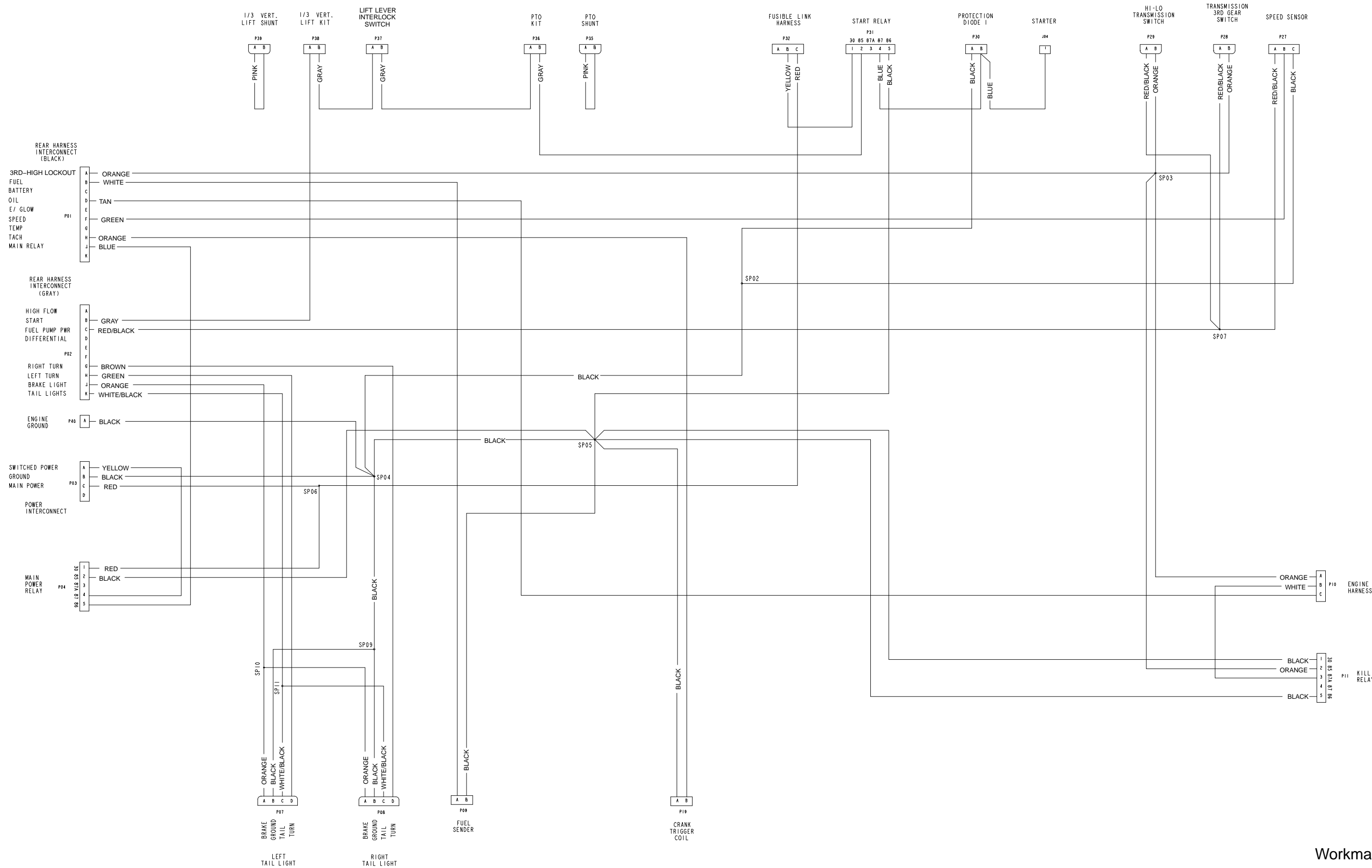

Workman HD  
 Kohler Gasoline Engine  
 Rear Wire Harness Diagram

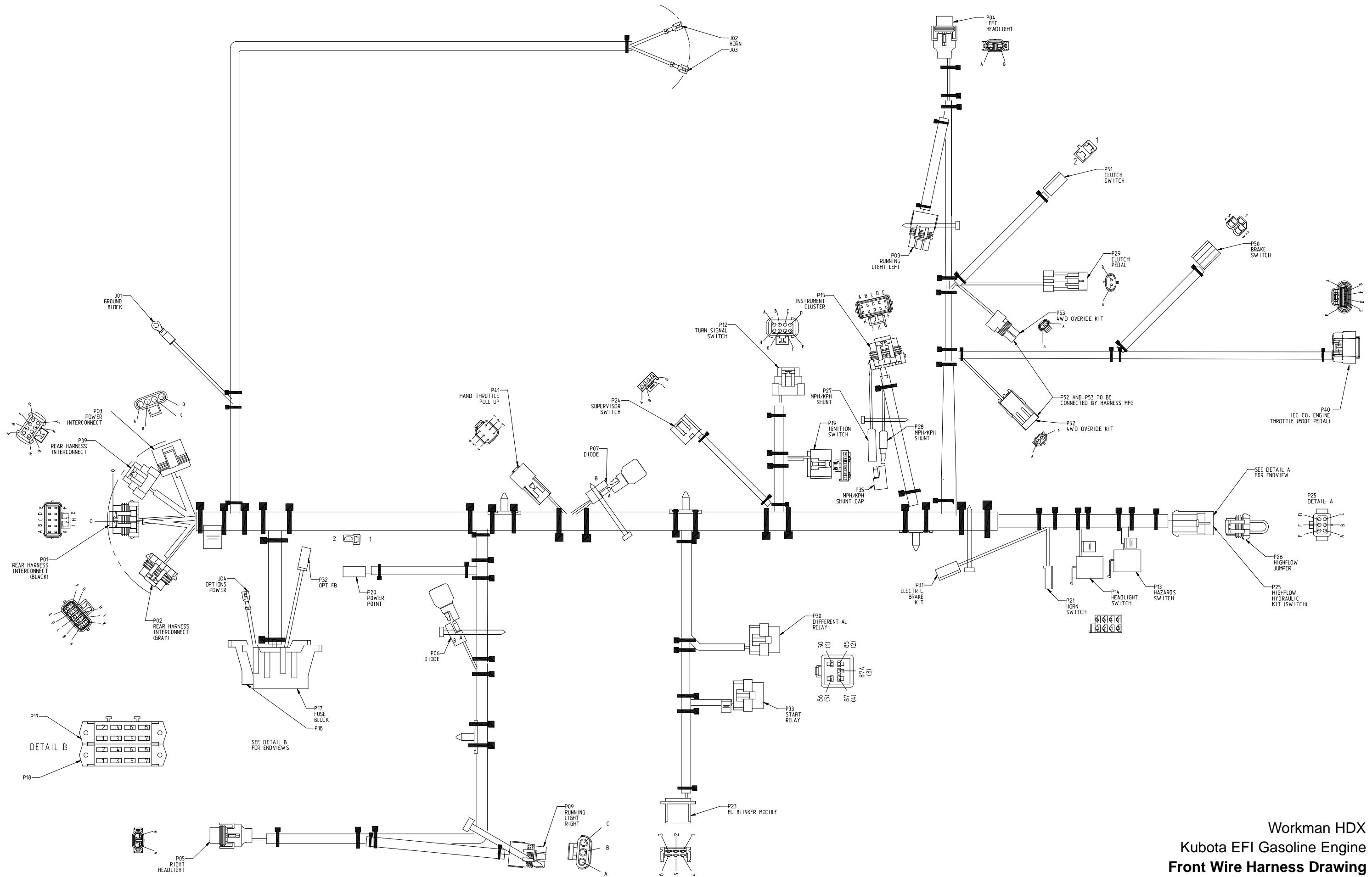

Workman HDX  
 Kubota EFI Gasoline Engine  
 Front Wire Harness Drawing



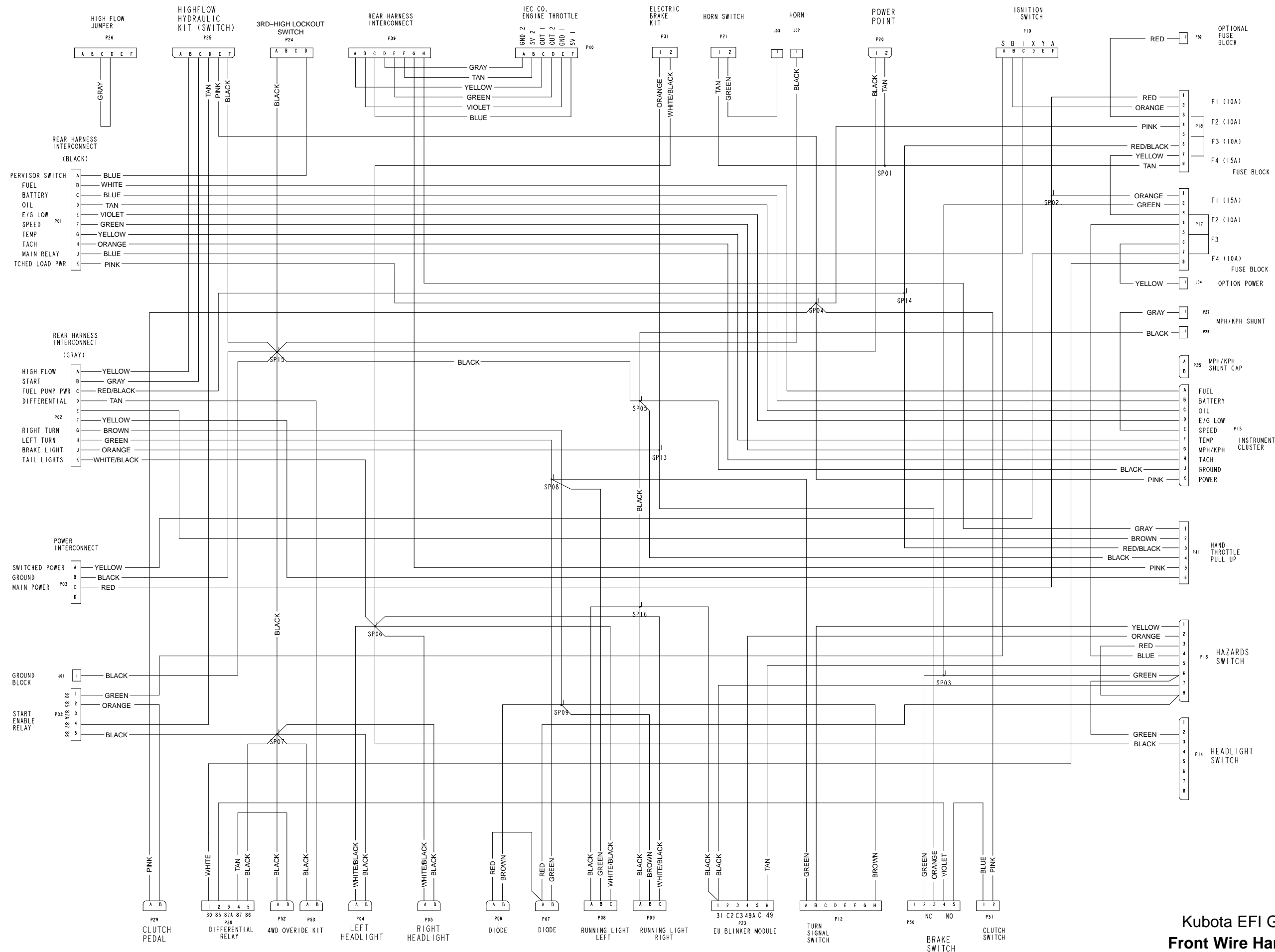

Workman HDX  
 Kubota EFI Gasoline Engine  
 Front Wire Harness Diagram

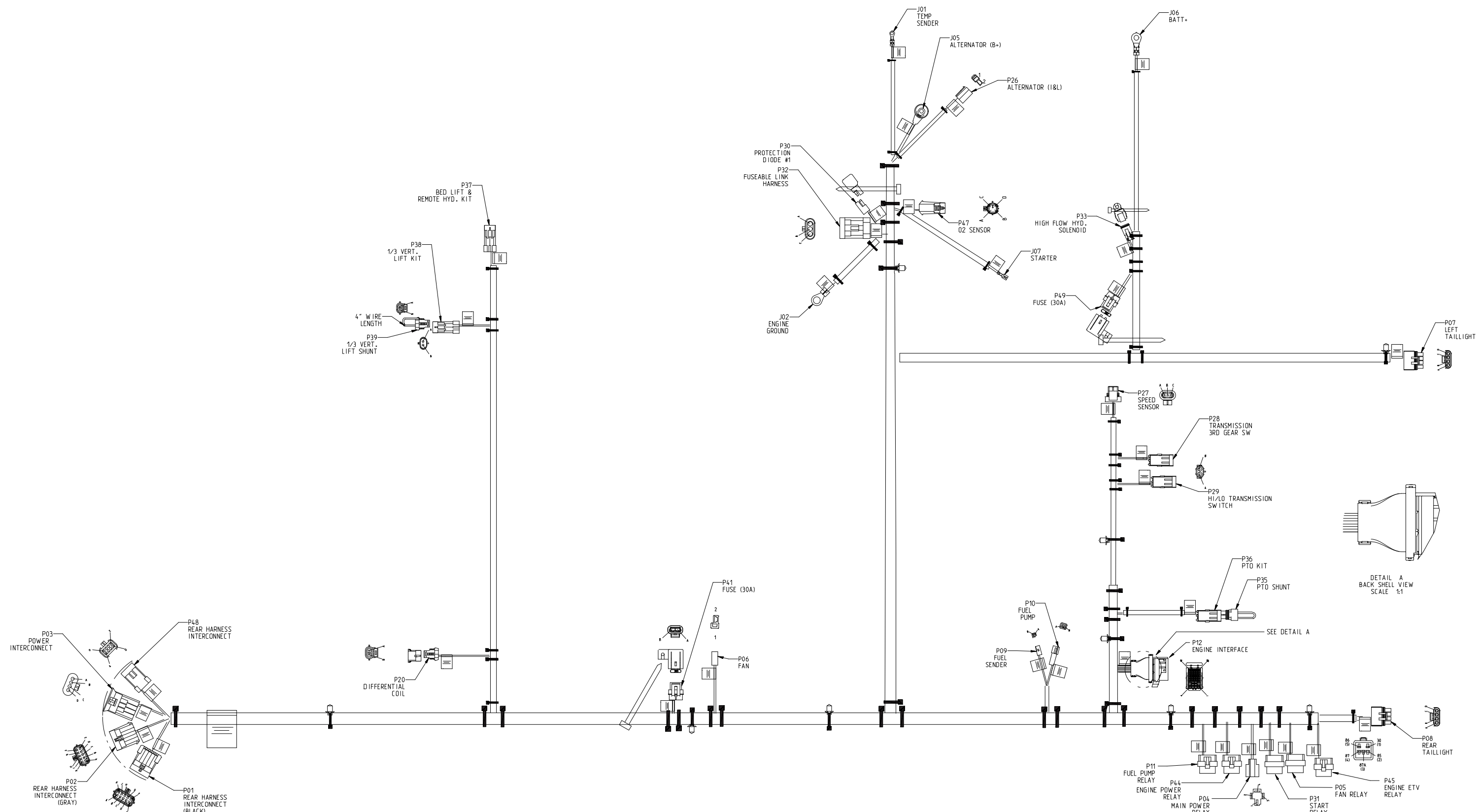

Workman HDX  
 Kubota EFI Gasoline Engine  
 Rear Wire Harness Drawing

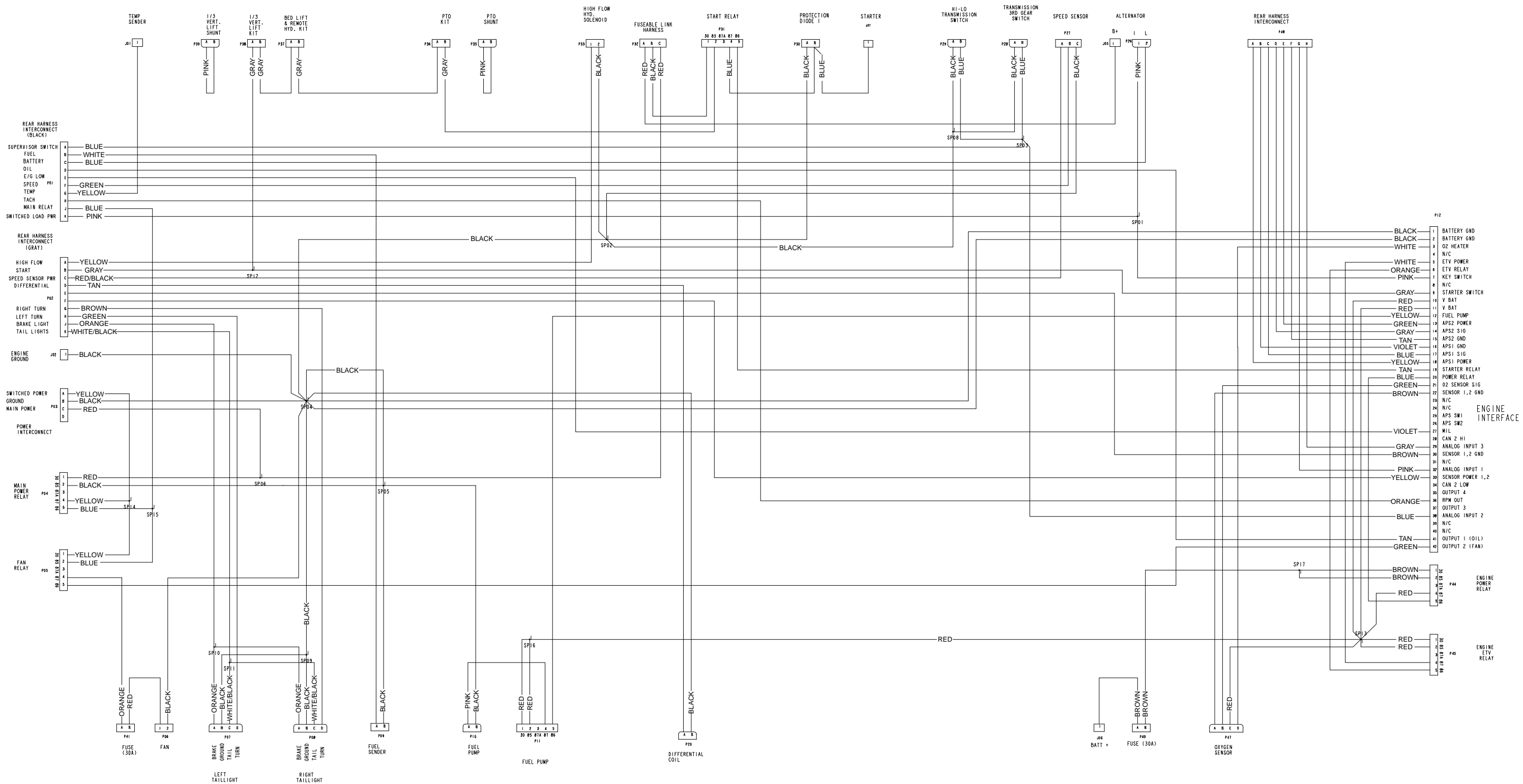

Workman HDX  
 Kubota EFI Gasoline Engine  
 Rear Wire Harness Diagram

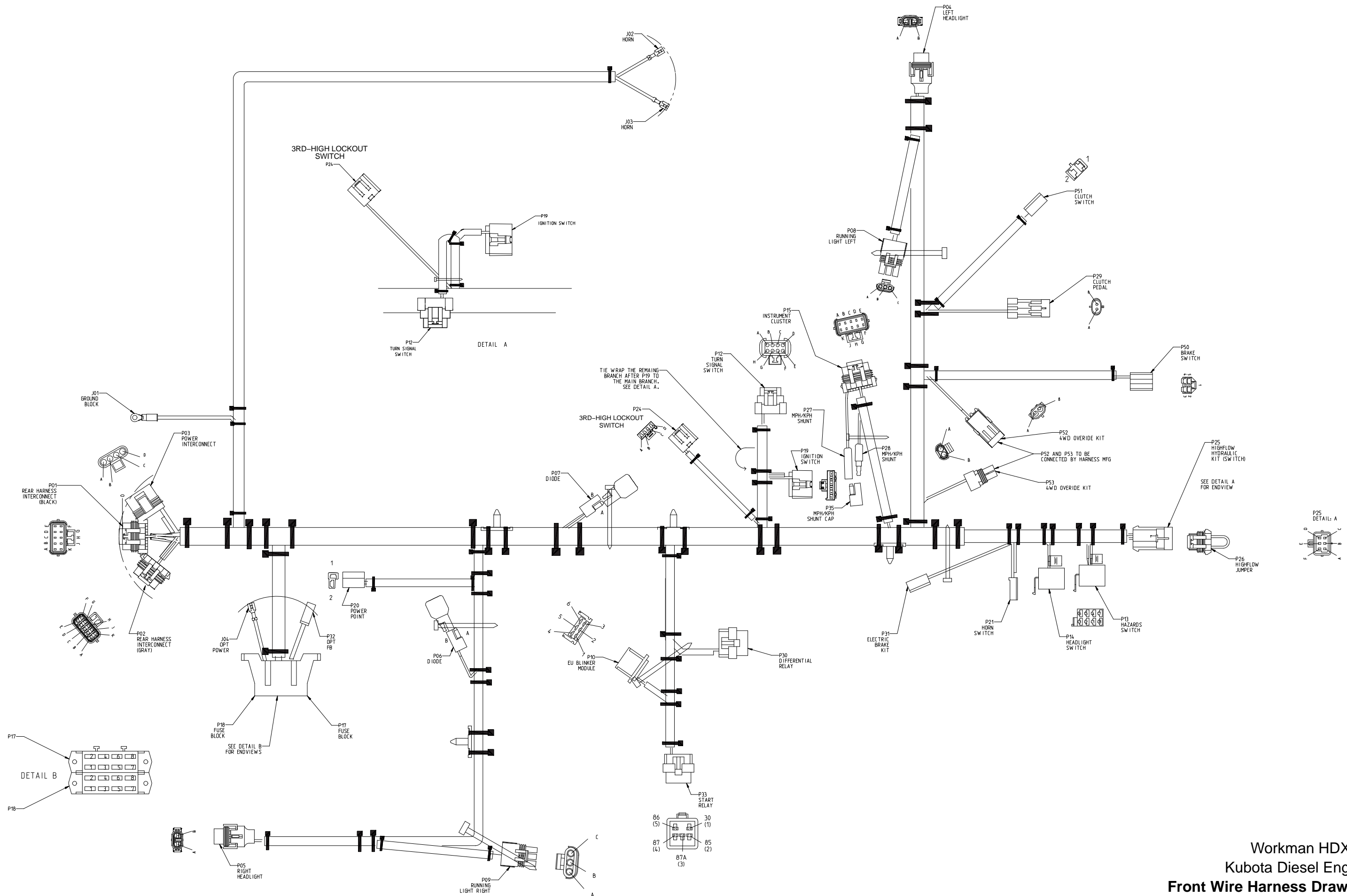

Workman HDX-D  
Kubota Diesel Engine  
Front Wire Harness Drawing

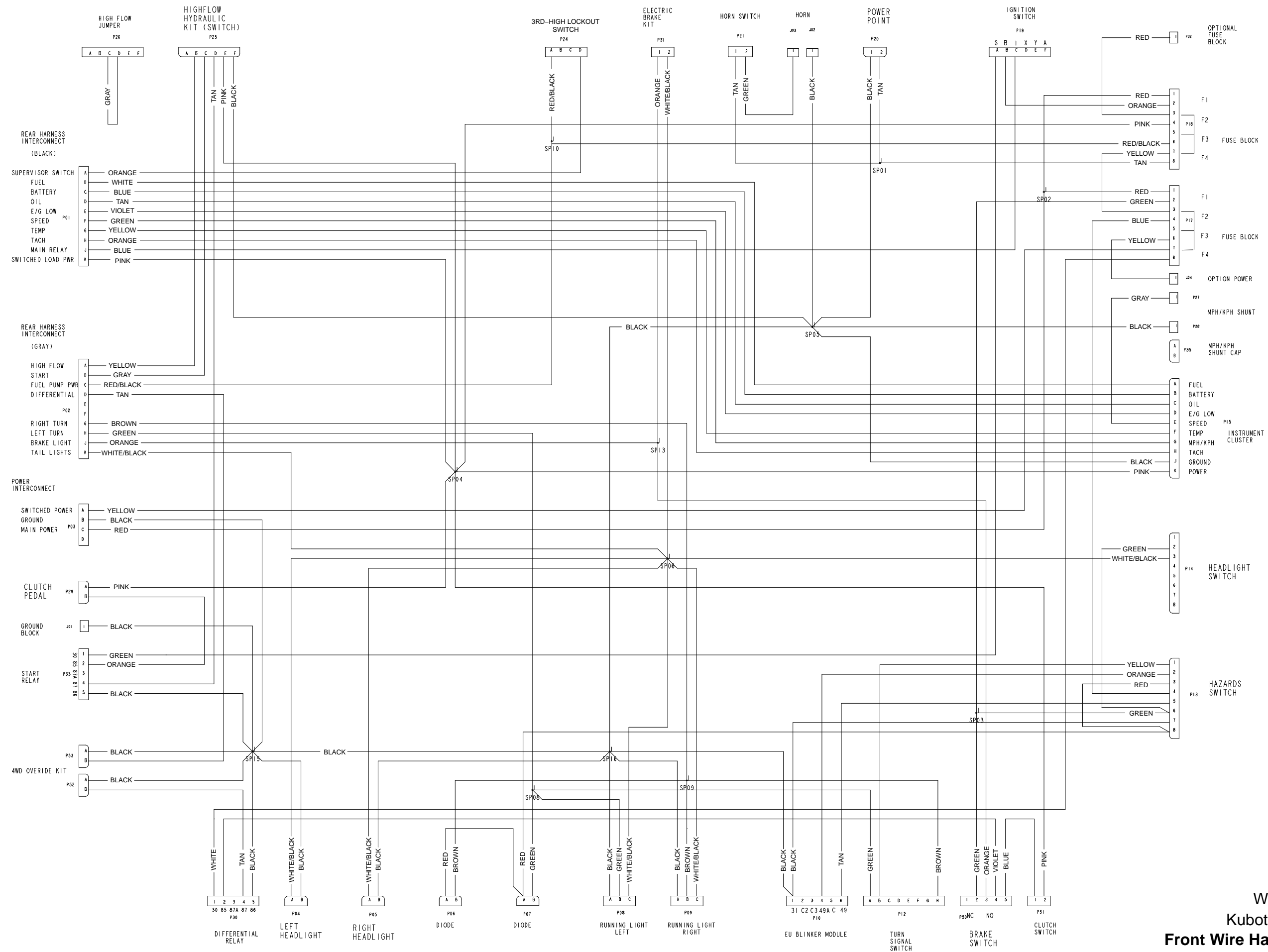

Workman HDX-D  
 Kubota Diesel Engine  
**Front Wire Harness Diagram**

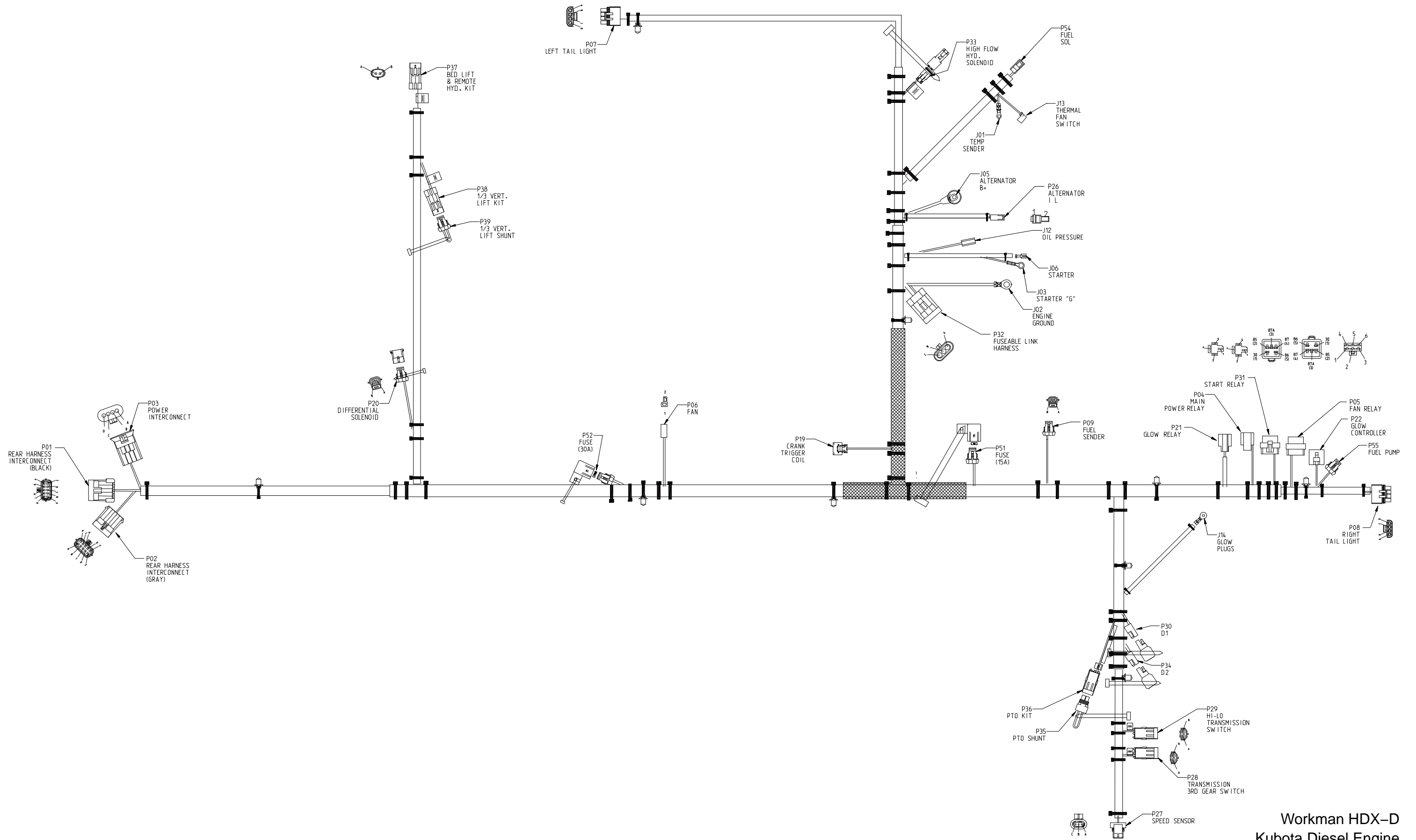

Workman HDX-D  
 Kubota Diesel Engine  
 Rear Wire Harness Drawing

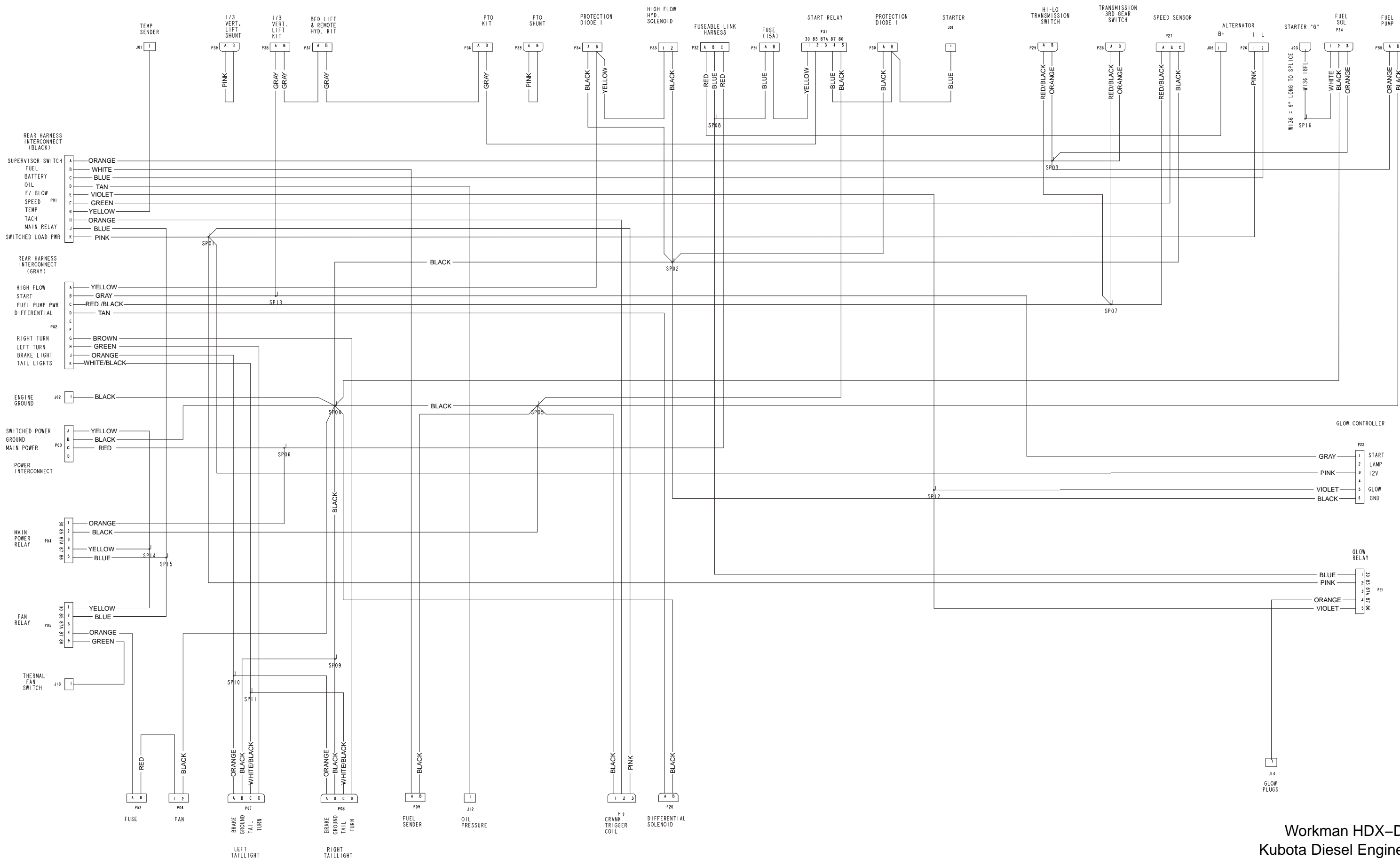

Workman HDX-D  
Kubota Diesel Engine  
Rear Wire Harness Diagram

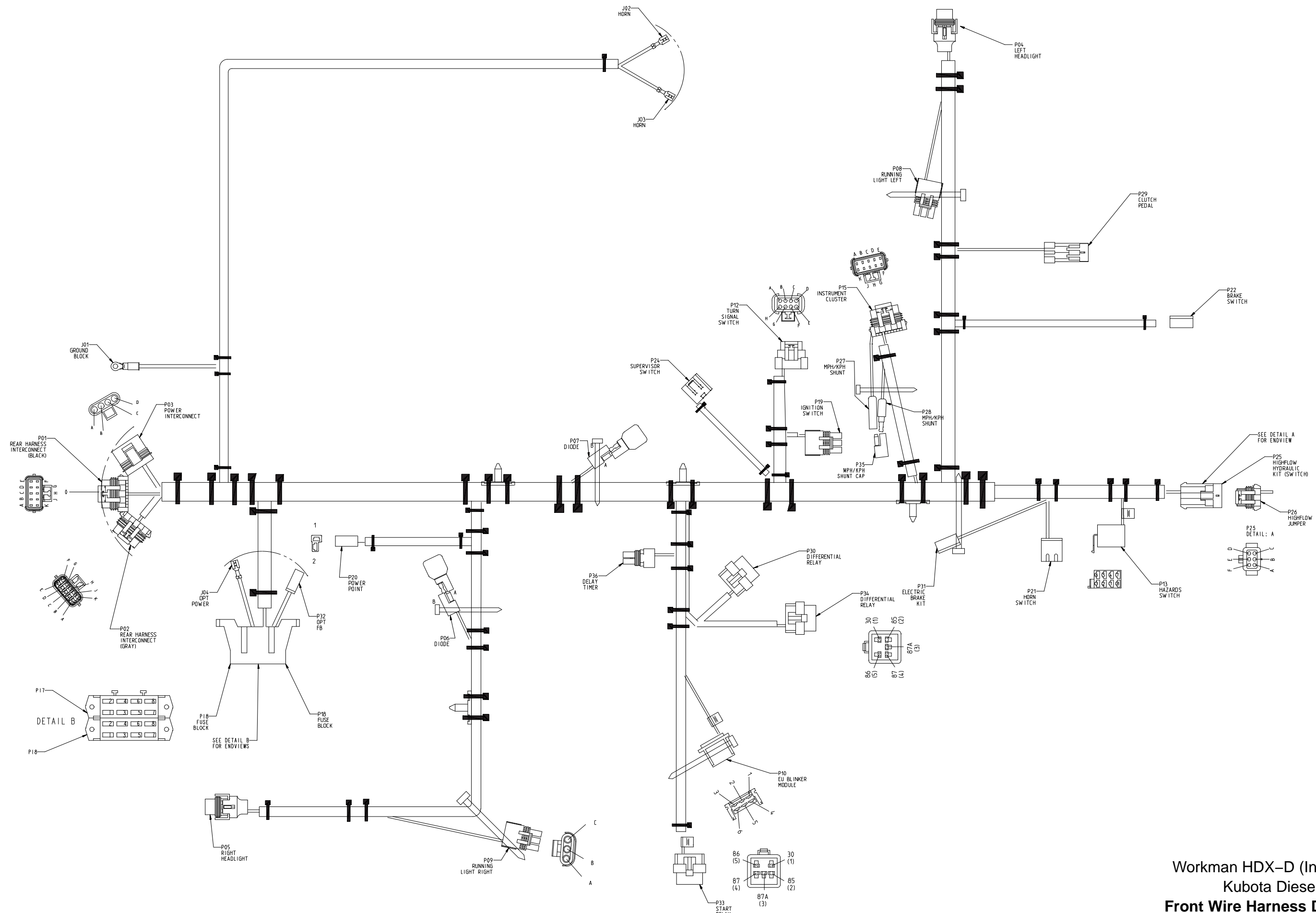

Workman HDX-D (Industrial)  
 Kubota Diesel Engine  
 Front Wire Harness Drawing



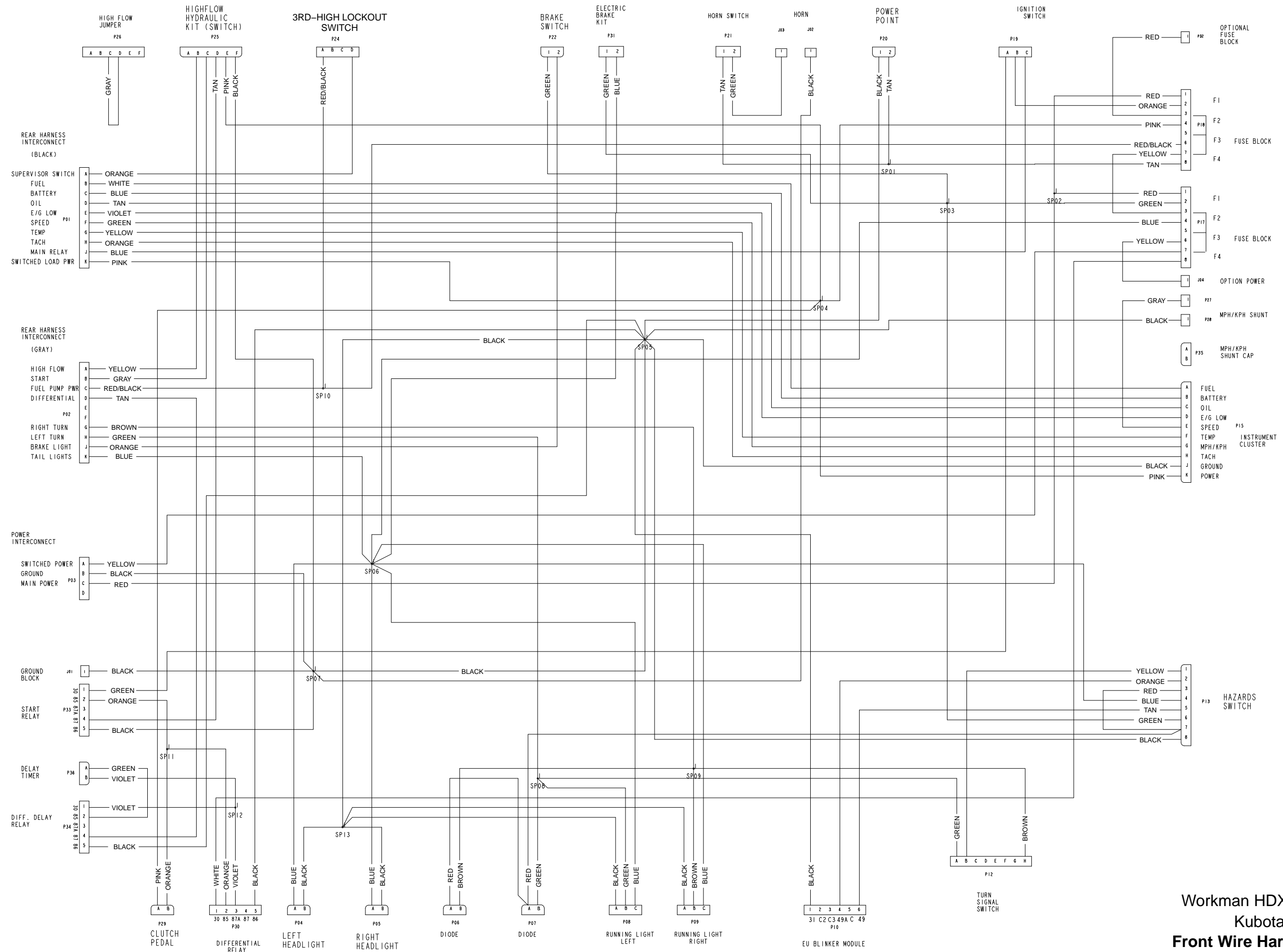

Workman HDX-D (Industrial)  
 Kubota Diesel Engine  
 Front Wire Harness Diagram

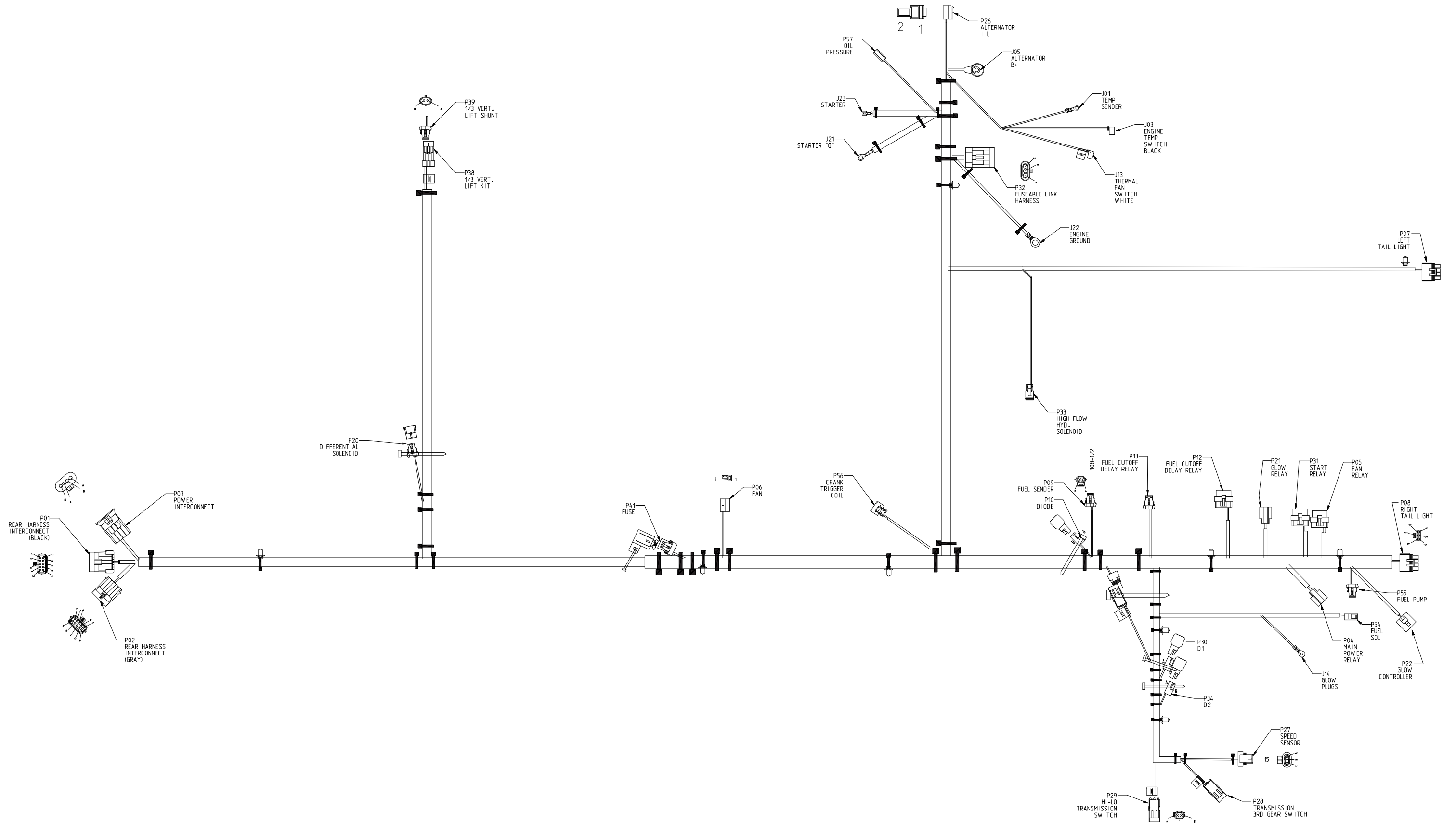

Workman HDX-D (Industrial)  
 Kubota Diesel Engine  
 Rear Wire Harness Drawing

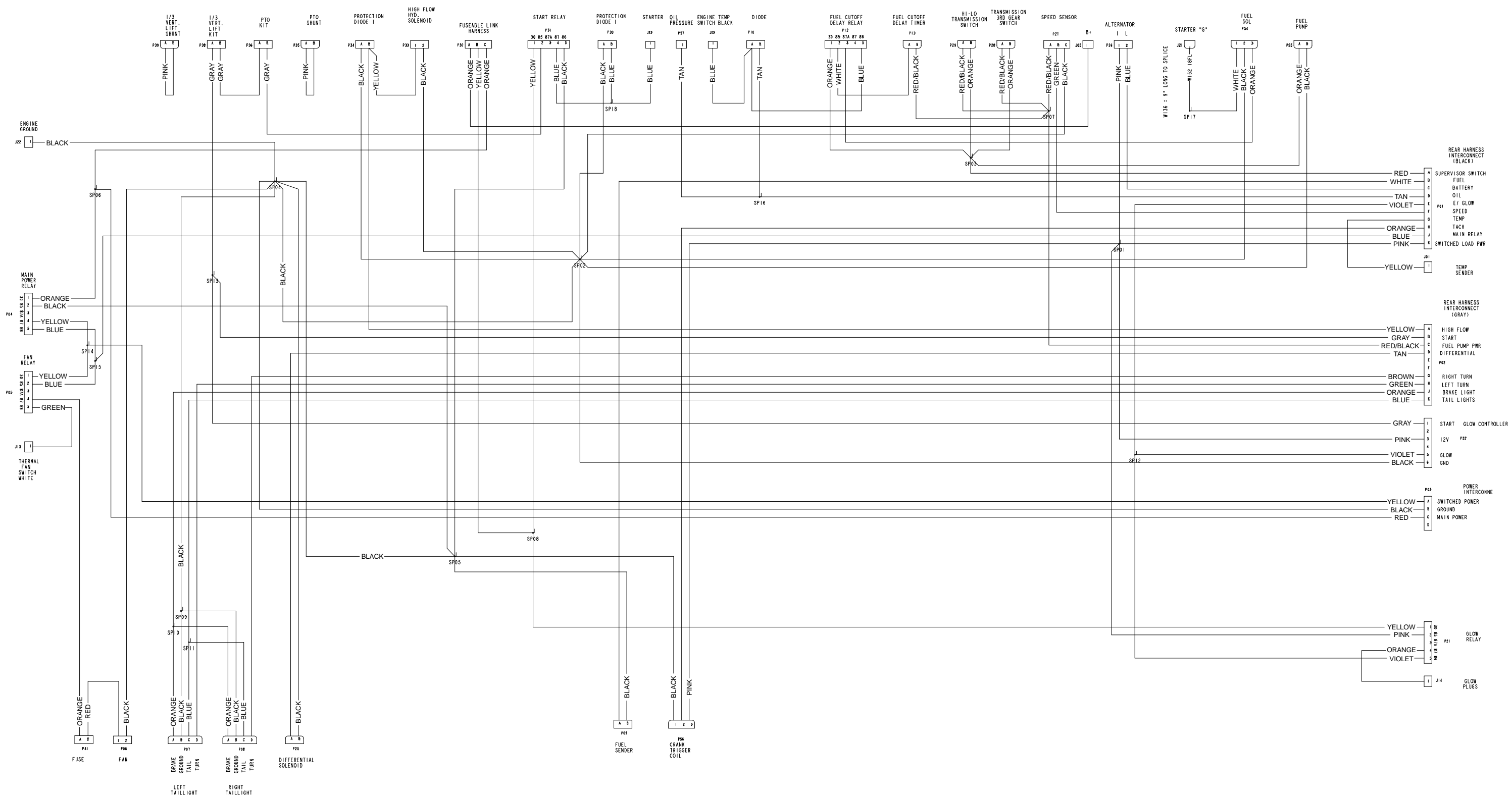

Workman HDX-D (Industrial)  
 Kubota Diesel Engine  
 Rear Wire Harness Diagram

This page is intentionally blank.